

# TECHNICAL CATALOGUE



## WORM GEARED MOTORS

STANDARD **IEC**



## 1. GENERAL INFORMATION

1.1	COMPANY PROFILE .....	6
1.2	PRODUCTS AND SOFTWARE MOTOVARIO .....	8
1.3	SYMBOLS AND FORMULAS .....	11
1.3.1	Symbols .....	11
1.3.2	Formulas .....	12
1.4	PRODUCT SELECTION .....	13
1.5	SERVICE FACTOR .....	14
1.6	INSTALLATION .....	15

## 2. PRODUCT INFORMATION

2.1	DESIGN FEATURES .....	16
2.2	TYOLOGY .....	17
2.2.1	Designation .....	17
2.2.2	Versions .....	23
2.2.3	Modularity .....	26
2.3	MOUNTING POSITIONS .....	29
2.3.1	Mounting positions .....	29
2.3.2	Position of terminal box .....	32
2.3.3	Position of terminal box - SW/CD .....	33
2.4	EFFICIENCY .....	34
2.4.1	Efficiency .....	34
2.4.2	Irreversibility .....	34
2.5	MESH DATA .....	35
2.6	ANGULAR BACKLASH .....	36
2.7	DIRECTION OF ROTATION .....	37
2.7.1	Direction of rotation .....	37
2.7.2	Direction of rotation - SW/CD .....	38
2.8	CRITICAL APPLICATIONS .....	39
2.8.1	Critical applications .....	39
2.8.2	Information .....	39
2.9	MOTOR FLANGE AVAILABILITY .....	40
2.9.1	NMRV - NMRV-P Motor flange availability .....	40

2.9.2	NMRV - NMRV-P HYBRID Motor flange availability .....	41
2.9.3	HA31+NMRV Motor flange availability .....	42
2.9.4	NMRV-P/HW Motor flange availability .....	43
2.9.5	SW Motor flange availability .....	44
2.9.6	SW HYBRID Motor flange availability .....	45
2.9.7	HA31+SW Motor flange availability .....	46
2.9.8	SW-CD Motor flange availability .....	47
2.9.9	Ratios NRV/NMRV/NMRV-P+NMRV/NMRV-P .....	48
2.9.10	Ratios ISW/SW+SW .....	50
<b>2.10</b>	<b>OUTPUT SHAFT BEARINGS</b> .....	<b>52</b>
<b>2.11</b>	<b>RADIAL LOAD</b> .....	<b>53</b>
2.11.1	Information .....	53
2.11.2	Input .....	53
2.11.3	Output .....	54
<b>2.12</b>	<b>LUBRICATION</b> .....	<b>55</b>
2.12.1	Information .....	55
2.12.2	Lubricants .....	55
2.12.3	Special lubricants .....	56
2.12.4	Quantity .....	57
<b>2.13</b>	<b>MOMENTS OF INERTIA</b> .....	<b>58</b>

### 3. DIMENSIONS

<b>3.1</b>	<b>REDUCERS/GEARED MOTORS</b> .....	<b>59</b>
3.1.1	NMRV 025 .....	59
3.1.2	NMRV 030-150 .....	60
3.1.3	SW .....	61
3.1.4	NRV .....	64
3.1.5	ISW .....	65
3.1.6	HA31+NMRV .....	68
3.1.7	HA31+SW .....	68
3.1.8	NMRV-P/HW .....	69
3.1.9	NMRV-P/IHW .....	70
3.1.10	NMRV/NMRV-P+NMRV/NMRV-P .....	71
3.1.11	NRV/NRV-P+NMRV/NMRV-P .....	72
3.1.12	SW+SW .....	73
3.1.13	ISW+SW .....	73
<b>3.2</b>	<b>WEIGHTS</b> .....	<b>74</b>

3.2.1	Weight NMRV [kg] .....	74
3.2.2	Weight SW [kg] .....	74
<b>3.3</b>	<b>SHAFT END</b> .....	<b>75</b>
<b>3.4</b>	<b>ELECTRIC MOTORS</b> .....	<b>76</b>
3.4.1	Electric motors .....	76
3.4.2	Standard high efficiency (TS), high (TH, SH, HSH) and premium (TP) motors .....	78
3.4.3	Nominal power - [kW] .....	79

## 4. ACCESSORIES AND OPTIONS

<b>4.1</b>	<b>LOW SPEED SHAFTS</b> .....	<b>80</b>
<b>4.2</b>	<b>OUTPUT FLANGE</b> .....	<b>81</b>
<b>4.3</b>	<b>SHAFT MOUNTING FASTENING</b> .....	<b>82</b>
4.3.1	Torque arm: Mounting position .....	82
4.3.2	Torque arm: Dimensions .....	84
<b>4.4</b>	<b>OUTPUT SHAFT COVER</b> .....	<b>85</b>
<b>4.5</b>	<b>TORQUE LIMITER</b> .....	<b>86</b>
4.5.1	Dimensions .....	86
4.5.2	Operating principle .....	87
4.5.3	Description .....	88
4.5.4	Slip torque setting .....	88
4.5.5	Adjustment graphs .....	89
<b>4.6</b>	<b>CLEAN DUTY</b> .....	<b>90</b>
4.6.1	Application description .....	90
4.6.2	Solutions .....	90
4.6.3	Surface treatment .....	91
<b>4.7</b>	<b>MACHINE AXIS</b> .....	<b>92</b>

## 5. NMRV - PERFORMANCES

<b>5.1</b>	<b>NMRV/NMRV-P WORM GEARED MOTOR (50Hz)</b> .....	<b>93</b>
<b>5.2</b>	<b>NRV/NRV-P WORM GEAR REDUCER - 2800 rpm</b> .....	<b>158</b>
<b>5.3</b>	<b>NRV/NMRV-P COMBINED WORM GEAR REDUCER - 2800 rpm</b> .....	<b>162</b>
<b>5.4</b>	<b>NRV/NRV-P WORM GEAR REDUCER - 1750 rpm</b> .....	<b>168</b>

5.5	NRV/NMRV-P COMBINED WORM GEAR REDUCER - 1750 rpm .....	172
5.6	NRV/NRV-P WORM GEAR REDUCER - 1400 rpm .....	178
5.7	NRV/NMRV-P COMBINED WORM GEAR REDUCER - 1400 rpm .....	182
5.8	NRV/NRV-P WORM GEAR REDUCER - 1140 rpm .....	188
5.9	NRV/NMRV-P COMBINED WORM GEAR REDUCER - 1140 rpm .....	192
5.10	NRV/NRV-P WORM GEAR REDUCER - 900 rpm .....	198
5.11	NRV/NMRV-P COMBINED WORM GEAR REDUCER - 900 rpm .....	202
5.12	NRV/NRV-P WORM GEAR REDUCER - 500 rpm .....	208
5.13	NRV/NMRV-P COMBINED WORM GEAR REDUCER - 500 rpm .....	212
5.14	IHW/NMRV-P WORM GEAR REDUCER WITH PRESTAGE - 1750 rpm .....	218
5.15	IHW/NMRV-P WORM GEAR REDUCER WITH PRESTAGE - 1400 rpm .....	220
5.16	IHW/NMRV-P WORM GEAR REDUCER WITH PRESTAGE - 1140 rpm .....	222
5.17	IHW/NMRV-P WORM GEAR REDUCER WITH PRESTAGE - 900 rpm .....	224

## 6. SW - PERFORMANCES

6.1	SW WORM GEARED MOTOR (50Hz) .....	226
6.2	ISW WORM GEAR REDUCER - 2800 rpm .....	266
6.3	ISW/SW COMBINED WORM GEAR REDUCER - 2800 rpm .....	269
6.4	ISW WORM GEAR REDUCER - 1750 rpm .....	273
6.5	ISW/SW COMBINED WORM GEAR REDUCER - 1750 rpm .....	276
6.6	ISW WORM GEAR REDUCER - 1400 rpm .....	280
6.7	ISW/SW COMBINED WORM GEAR REDUCER - 1400 rpm .....	283
6.8	ISW WORM GEAR REDUCER - 1140 rpm .....	287
6.9	ISW/SW COMBINED WORM GEAR REDUCER - 1140 rpm .....	290
6.10	ISW WORM GEAR REDUCER - 900 rpm .....	294
6.11	ISW/SW COMBINED WORM GEAR REDUCER - 900 rpm .....	297
6.12	ISW WORM GEAR REDUCER - 500 rpm .....	301
6.13	ISW/SW COMBINED WORM GEAR REDUCER - 500 rpm .....	304

## 7. SALES CONDITIONS

7.1	SALES CONDITIONS .....	308
-----	------------------------	-----

Motovario® corporate philosophy aims to promote the company's brand and products at an international level with determination and transparency, while constantly striving to offer innovative solutions for satisfying and anticipating the demand of the market. Motovario® provides technologically advanced solutions in the transmission components field for industrial and civil applications worldwide.

### The company

At Formigine, the heart of Modena's industrial district, Motovario® boasts a production plant spanning 50,000 m<sup>2</sup> that employs 500 people.

1965 Foundation of Motovario

1998 Acquisition of Spaggiari Trasmissioni, an important brand in the mechanical technology sector.

2006 Motovario acquisition by a private investment fund managed by Synergo SGR, in order to guarantee its development and support its expansion throughout the world.

2014 Acquisition of Pujol.

2015 Acquisition by TECO.

At the core of Motovario® lies an evolved production process based on technological solutions that convert power into movement. Motovario® is at the heart of the production processes that drive industries worldwide. Quality and reliability are the company's fundamental assets. Motovario® is present throughout the world with branches in France, Spain, Germany, England, China, the United States and India. The sales network and customer service guarantee immediate and high-quality support to all customers. In addition, the company boasts a worldwide network of MAC (Motovario Assembly Centre). Qualified assembly centres are present, in Italy, Australia, Benelux, Bulgaria, China, Finland, France, India, Ireland, Israel, Malaysia, Poland, Portugal, South Korea, Spain, Sweden, Turkey, United Kingdom, Ukraine and USA. The company is able to offer a wide range of products: speed variators, right-angle, helical-bevel, shaft-mounted, worm gear reducers and gearmotors, electric motors, inverter and inverter drives. Maximum quality and precision are ensured by the cutting-edge technologies implemented in the production process. 170 numerical control machines, served by LGV lines for storage in automatic warehouses, ensure a high standard of efficiency for the Motovario® production department.

The highly automated assembly lines are supported by a specific computerised system. The process statistical control system manages the production process to avoid rejects, by enabling the operator to monitor all the processing phases. The annealing, tempering, hardening and carburizing treatments are carried out inside the plant. The plant operates on a 24-hour basis, including holidays. Reliability, resilience and versatility are the distinctive features of Motovario® products, the most qualified solution to any power transmission requirement.

### Main fields OF APPLICATIONS

- Mechanical-electromechanical industry (car washing, pumps, barriers & automatic doors, circuit breakers)
- Ceramic industry (ovens, press feeding systems)
- Food, farming, oenology industry
- Wood, marble, glass industry
- Packaging & bottling industry
- Textile, shoes, leather industry
- Transport, logistic industry
- Construction industry
- Milling, animal husbandry, flower industry
- Machine tools & steel industry
- Mining, quarry, cement industry
- Energy industry (solar, nuclear, biomass, wind)
- Amusement industry (theatres, leisure parks, kiddy rides)
- Chemical & pharmaceuticals industry
- Paper & printing industry
- Plastic & rubber industry
- Telecommunications industry (satellite orientation systems, military radar)
- Engineering and consultant companies



### Certifications

Our products can be manufactured to conform with the ATEX Directive 2014/34/UE. In addition, the safety and quality of our motors, geared motors and motovariators is guaranteed by the EAC (EurAsian Conformity) certification, an essential requirement for products exported to the Russian Federation. Our motors are UL certified, which guarantees their safety and quality requirements for the North American market.

### Quality CONCEPT

Motovario® has obtained the quality certification renewal of its production system in conformity to the UNI EN ISO 9001:2008 standard. This internationally recognised certification acknowledges the company's commitment and drive geared towards constantly improving products, projects and services offered. Moreover, the company has obtained the OHSAS 18001:1999 (Occupational Health and Safety Assessment Series) certification, which defines the requirements of the workplace safety and health management system.

### Research & DEVELOPMENT

Technological innovation: a crucial factor for competing in the market. In the company's 50-year history, research and change have been the pivotal factors in guaranteeing competitiveness at a global level, thanks to increasingly advanced products in terms of performance and reliability. Each year the company invests an increasing amount of its turnover in research and development, geared towards promoting the constant study and analysis of products, control processes and performance certification. In order to ensure that customers receive products that comply with the requested performance levels, the company carries out simulations on all new products, including NVH (Noise, Vibration, Harshness) tests effected in the advanced semi-anechoic chamber.

### Customer CARE

Innovative instruments and software applications supporting the technical and logistic requirements of our partners worldwide guarantee a timely and customised service. The experience acquired by Motovario® has led to the creation of the new online portal MyMotovario 4.0, which allows for selecting products and exporting their 3D file. As a result, designers and engineering departments can download the three-dimensional model of the requested product and implement it directly in their own layout. In order to maximise customer service and quality, Motovario® offers all its customers the following online services: Order Tracking, which allows for monitoring the progress of an order in real time, and the Stock Availability service, through which users may check the availability (stock) of our products, both in the Italian plant and in the various branches.

### Motovario chooses technological evolution.

Motovario® has chosen technological evolution and actively collaborates with the Faculty of Engineering of the University of Modena and Reggio Emilia and of the University of Bologna.

**Reliability, sturdiness, versatility**

These are the distinctive traits of Motovario products. A broad range of transmission products that provide a competent, innovative solution to each and every power application need. Cutting-edge tools, unrelenting research efforts and ongoing commitment to upgrading manufacturing equipment to the latest state-of-the-art enable us to offer high quality and performance standards to cater to industry requirements and the broadest variety of applications. Motovario ranks among the leading, well-reputed companies in Italy engaged in the design, manufacture and sales of transmission products for industrial and civil applications. The entire manufacturing process takes place in Formigine and Ubersetto plants, in Modena area, with an overall surface area of over 50.000 sq m. and a workforce of about 500 people. 170 numerically controlled machines and cutting-edge handling, storage and assembly automated systems ensure that all products meet high quality standards. The network includes more than 40 Motovario-certified assembly centres, with the capability to supply products in a broad range of versions, including customised versions, high service capacity and fast response. As a result, our product offering can cater to the needs of all plant engineering sectors, in all industries and for different applications, and includes: speed variators, helical, bevel-helical, parallel helical, worm gear reducers and gearmotors, electric motors and motor-inverters. All of the products we manufacture share such common features as reliability, sturdiness and versatility, topped with a high innovation content. At the heart of a company's technological innovation is the ability to develop integrated tools for computer-aided calculation simulation and management of different processes as part of product development. When simulating operating, setup and process conditions, it is also necessary to analyse and optimize the overall functional design of a product using a synergistic approach. This is achieved by implementing an exhaustive experimental plan, without using interpolation or approximation, as they frequently allow criticalities or any oversizing which is not conducive to maximising quality/cost ratio to go unnoticed.

**High-efficiency method for calculation according to standards**

A set of specific functions have been developed to this end. A few significant examples include functions to:

- Optimise individual reduction ratios and the combinations of the different reduction stages based on parametrisable target normal series;
- Calculate torque values and maximum permissible external forces for gear reducer units, using iterative numeric algorithms to confirm target life/safety values of components;
- Create databases for loading a FEM structural analysis model by automatically writing all reaction components of bearings under all load conditions to a specific file, with automatic selection of critical cases that need to be verified.

Another goal of the method is to create synergy between calculation according to standards and FEM structural calculation and the implementation of FEM model loading procedures, so as to simplify input data, meshing and constraint criteria

**Competitiveness and operational benefits of the new method**

This method offers many practical advantages over traditional calculation procedures within the company, namely:

- Iterative optimisation of project since setup stage;
- Accurate assessment of the various service factors and reliability levels for the entire gear reducer unit and for all operating conditions as per catalogue rating or customer specific requirements;
- Faster support to customers in analysing tailored product configurations;
- Integrated corporate databases that can be updated in real-time.

**Range extension and ongoing evolution**

The steady, significant growth of Motovario Group is achieved thanks to an ongoing search for new calculation and design tools, as well as to customer service. The new tools identified have led to innovation, improved product reliability as well as positive developments in market management. The following software products are used for design, calculation and management:

- Solidworks;
- Kisoft;
- Kissys;
- Ansys;
- FEM modelling analysis software;
- Circuit design and simulation software;
- Specific spreadsheets;
- SAP.

In MyMotovario 4.0 portal, PRODUCT SELECTION includes a section named APPLICATIONS where customers can enter application data and find out which gear reducer suits them best in a matter of minutes.

## MOTOVARIO Products

<p><b>HELICAL GEAR REDUCERS</b></p> <p>Cast iron or aluminum casing Output shaft up to 90 mm Mn<sub>2</sub> up to 8.600 Nm Reduction stages 1, 2, 3 Ratios up to 354 Atex units</p>	
<p><b>HELICAL BEVEL GEAR REDUCERS</b></p> <p>Cast iron or aluminum casing Output shaft up to 110 mm Mn<sub>2</sub> up to 14.000 Nm Reduction stages 2, 3 Ratios up to 443 Atex units</p>	
<p><b>SHAFT MOUNTED GEAR REDUCERS</b></p> <p>Cast iron Output shaft up to 90 mm Mn<sub>2</sub> up to 10.250 Nm Reduction stages 2, 3 Ratios up to 395 Atex units</p>	
<p><b>WORM GEAR REDUCERS</b></p> <p>Cast iron or aluminum casing Output shaft up to 50 mm Mn<sub>2</sub> up to 2.700 Nm Ratios up to 1083 Atex units</p>	
<p><b>PLANETARY GEARED UNITS</b></p> <p>Cast iron Output shaft up to 80 mm Mn<sub>2</sub> up to 10000 Nm Reduction stages 1, 2, 3, 4 Ratios up to 2700</p>	

<p><b>PARALLEL HELICAL AND BEVEL HELICAL GEAR REDUCERS FOR MIDDLE HEAVY INDUSTRY</b></p> <p>Cast iron casing  Output shaft up to 180 mm  Mn<sub>2</sub> up to 110.000 Nm  Reduction stages 2, 3, 4  Ratios up to 431  Atex units</p>	
<p><b>MOTOVARIATORS AND MOTOVARIATOR-GEAR REDUCERS</b></p> <p>Cast iron or aluminum casing  Mn<sub>2</sub> up to 5.000 Nm  Atex units</p>	
<p><b>ELECTRIC MOTORS</b></p> <p>Power ratings up to 90 kW  Poles 2, 4, 6  Three-phase and single-phase, built-in brake, dual polarity  Protection class up to IP66</p>	
<p><b>DRIVES</b></p> <p><b>DRIVON - motoinverter</b></p> <p>Three phase and single phase power supply  High dynamics sensorless vectorial control  Power ratings up to 5,5 kW  Standard integrated STO  Integrated field bus  Optional field bus</p>	

## 1.3.1 Symbols

Physical dimension	Symbol	Symbol units of measure	Input	Output
Power	P	[kW]	P <sub>1</sub>	P <sub>2</sub>
Requested power	Pr	[kW]	Pr <sub>1</sub>	Pr <sub>2</sub>
Nominal power	Pn	[kW]	Pn <sub>1</sub>	Pn <sub>2</sub>
Torque	M	[Nm]	M <sub>1</sub>	M <sub>2</sub>
Nominal torque	Mn	[Nm]	/	Mn <sub>2</sub>
Requested torque	Mr	[Nm]	Mr <sub>1</sub>	Mr <sub>2</sub>
Speed	n	[rpm]	n <sub>1</sub>	n <sub>2</sub>
Load	F	[N]	/	/
Radial load	Fr	[N]	Fr <sub>1</sub>	Fr <sub>2</sub>
Radial axial	Fa	[N]	Fa <sub>1</sub>	Fa <sub>2</sub>
Reduction ratio	i	[ ]	/	/
Dynamic efficiency	η <sub>d</sub>	[ ]	/	/
Service factor	f.s.	[ ]	/	/
Static	s	[ ]	/	/
Dynamic	d	[ ]	/	/
Calculated	c	[ ]	/	/
Maximum	max	[ ]	/	/
Minimum	min	[ ]	/	/
Moment of inertia	J	[kgm <sup>2</sup> ]	J <sub>1</sub>	J <sub>2</sub>
Ambient temperature	T <sub>amb</sub>	[°C]	/	/
Dimension		[mm]	/	/
Number of screw threads	Zl	[ ]	/	/
Lead angle	Υ	[° ' '' ]	/	/
Axial module	Mx	[ ]	/	/
Dynamic efficiency of n1= 1400 rpm	η <sub>δ</sub> (1400)	[ ]	/	/
Static efficiency	η <sub>s</sub>	[ ]	/	/

## 1.3.2 Formulas

REDUCER		
Starting or stopping time	$t = v / a$	[s]
Velocity in rotary motion	$v = \pi * d * n / 60$ $v = \omega * r$	[m/s]
Speed velocity Angular velocity	$n = 60 * v / (\pi * d)$ $\omega = v / r$	[rpm] [rad/s]
Acceleration or deceleration according to a starting / stopping time	$a = v / t$	[m/s <sup>2</sup> ]
Angular acceleration	$\alpha = n / (9,55 * t)$ $\alpha = \omega / t$	[rad/s <sup>2</sup> ]
Starting or stopping distance (according to acceleration / deceleration or angular velocity)	$s = a * t^2 / 2$ $s = v * t / 2$	[m]
Horizontal translation force	$F = \mu * m * g$	[N]
Vertical translation force (lifting)	$F = m * g$	
Inclined plane translation force	$F = m * g (\mu * \cos\beta + \sin\beta)$	
m= mass [kg]; g= gravity acceleration [m/s <sup>2</sup> ]; $\mu$ = friction coefficient; $\beta$ = angle of inclination		
Moment of inertia	$J = m * v^2 / \omega^2$	[kgm <sup>2</sup> ]
Torque	$M = F * d / 2$ $M = J * \omega / t$	[Nm]

MOTOR and GEARMOTOR		
Starting time	$t_a = (J_{ext} + J_m) * n_n / 9,55 + (M_{peak} - M_r)$	[s]
Braking time	$t_s = (J_{ext} + J_m) * n_n / 9,55 + (M_{peak} + M_r)$	[s]
Motor rotation angle during starting	$\varphi = n_n * t_a / 19,1$	[rad]
Motor rotation angle during braking	$\varphi = n_n * t_s / 19,1$	[rad]
Power available at the shaft of single phase motor	$P = V * I * \eta * \cos\omega$	[W]
Power available at the shaft of three phase motor	$P = 1,73 * V * I * \eta * \cos\omega$	[W]

RUNNING at 60Hz		
Speed velocity at 60Hz	$n_{60Hz} = 1,2 * n_{50Hz}$	[rpm]
Power at 60Hz	$P_{1\ 60Hz} = P_{1\ 50Hz} * V_{60Hz} / V_{50Hz}$	[kW]
If input voltage at 60 Hz ( $V_{60Hz}$ ) corresponds to winding voltage at 50 Hz ( $V_{50Hz}$ ), power doesn't change $P_{1\ 60Hz} = P_{1\ 50Hz}$		
If input voltage at 60 Hz ( $V_{60Hz}$ ) is 20% higher than winding voltage at 50 Hz ( $V_{50Hz}$ ), power increases by 20% $P_{1\ 60Hz} = 1,2 P_{1\ 50Hz}$		
Torque at 60Hz	$M_{60Hz} = M_{50Hz} * P_{1\ 60Hz} / (1,2 * P_{1\ 50Hz})$	[Nm]
Service factor at 60Hz	$f.s_{60Hz} = f.s_{50Hz} * 1,175 * P_{1\ 50Hz} / P_{1\ 60Hz}$	-

For correctly selecting a gear reducer or geared motor, several essential pieces of data are required:

1. The rotational input speed to the gear reducer ( $n_1$ ) and the rotational output speed ( $n_2$ ). Through these two values it is possible to calculate the reduction ratio ( $i$ ) of the gear reducer using the following formula:  $i = n_1/n_2$
2. The torque required by the application ( $M_{r2}$ ).

The geared motor or gear reducer can be selected once this data is known.

This guide helps you to select the right product in just a few steps:

#### Geared motor selection

1. Determine the application's actual service factor (**s.f.**). This parameter depends on the type of load of the powered machine, the number of starts per hour and the hours of operation (refer to the "Service factor" paragraph).
2. Calculate the input power  $P_{r1}$  using the required torque value  $M_{r2}$ , the speed  $n_2$  and dynamic efficiency value.  $P_{r1} = (M_{r2} * n_2) / (9550 * \eta_d)$ . The dynamic efficiency value depends on the type of gear reducer and on the number of gear reduction stages. (To calculate the efficiency value see its page).
3. Consult the geared motor performance tables and identify a nominal power value  $P_{n1}$  exceeding the required power  $P_{r1}$ , such that:  $P_{n1} \geq P_{r1}$
4. Once the suitable nominal power has been identified, select the geared motor capable of generating the rotational speed closest to the desired  $n_2$  value and with service factor s.f. greater or equal to that required by the application.

In the geared motor selection tables the combinations include 2-pole, 4-pole and 6-pole motors powered at 50Hz.

#### Gear reducer selection

1. Determine the application's service factor (**s.f.**) (consult to the "Service factor" paragraph on its page).
2. Calculate the reduction ratio  $i$  from the requested output speed  $n_2$  and from the input speed  $n_1$ .  $i = n_1/n_2$
3. Calculate the torque  $M_{c2}$  for selecting the gear reducer through the torque required by the application  $M_{r2}$  and the service factor s.f.:  $M_{c2} = M_{r2} * (s.f.)$
4. Consult the Gear Reducer Performance tables looking for the reducer that, with the reduction ratio closer to the calculated one, has a nominal torque  $M_{n2}$  so that:  $M_{n2} \geq M_{c2}$

#### Checks

Once the gear reducer or geared motor has been selected, the following checks should be performed:

##### A. Maximum torque

Generally, the maximum torque (peak instantaneous load) that can be applied to the gear reducer must not exceed 200% of the nominal torque  $M_{n2}$  (ATEX -  $M_{2max}$ ).

##### B. Radial loads

1. Verify that the radial loads acting on the input and/or output shafts are within with the values indicated in the catalogue. If they exceed these values, increase the size of the gear reducer or modify the external load capacity. During the checking phase, it is important to remember that the values indicated in the catalogue refer to loads acting on the mid-point of the shaft protrusion, therefore, if the load is applied to a different position, appropriate formulas must be used to calculate the admissible load in the desired position (refer to the "Radial loads" paragraph).
2. If accessory output shafts are present, make sure that the applied load is compatible with shaft size. If help is needed: contact MOTOVARIO TECHNICAL SERVICE.

- C. If an electric motor is going to be fitted to the selected gear reducer, check for its applicability by referring to the configuration table (see paragraph "Motor flange availability"). From IEC 180 motors, verify if necessary to support the motor with feet. In case of need please contact MOTOVARIO TECHNICAL SERVICE.

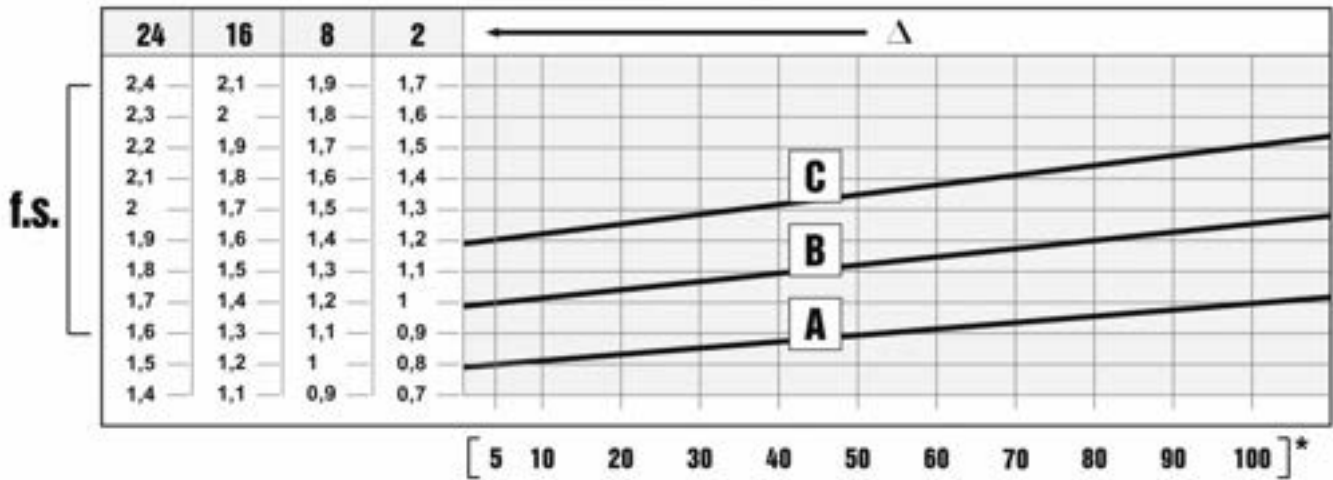

The service factor (f.s.) depends on the operating conditions the gear reducer is subjected to.

The parameters that need to be taken into consideration to select the most adequate service factor correctly comprise:

- type of load of the operated machine : A - B - C
- length of daily operating time: hours/day ( $\Delta$ )
- start-up frequency: starts/hour (\*)

#### LOAD:

- **A** - uniform =  $f_a \leq 0,3$
- **B** - moderate shocks =  $f_a \leq 3$
- **C** - heavy shocks =  $f_a \leq 10$

#### $f_a = J_e/J_m$

- $J_e$  [ $\text{kgm}^2$ ] moment of reduced external inertia at the drive-shaft
- $J_m$  [ $\text{kgm}^2$ ] moment of inertia of motor

If  $f_a > 10$  call MOTOVARIO TECHNICAL SERVICE.

In the case of a variable speed reducer, once determined the service factor of the application it is necessary to compare this value with the safety factor of the S reducer reported in the selection tables, verifying  $S \geq f.s.$  condition. The maximum number of admissible starts depends on the type of application. Approximately, the figure must not exceed 5-10 for minute. Contact MOTOVARIO TECHNICAL SERVICE if you have any special requirements.

- Screw feeders for light materials, fans, assembly lines, conveyor belts for light materials, small mixers, lifts, cleaning machines, fillers, control machines.
- Winding devices, woodworking machine feeders, goods lifts, balancers, threading machines, medium mixers, conveyor belts for heavy materials, winches, sliding doors, fertilizer scrapers, packing machines, concrete mixers, crane mechanisms, milling cutters, folding machines, gear pumps.
- Mixers for heavy materials, shears, presses, centrifuges, rotating supports, winches and lifts for heavy materials, grinding lathes, stone mills, bucket elevators, drilling machines, hammer mills, cam presses, folding machines, turntables, tumbling barrels, vibrators, shredders.



**To install the gear reducer it is necessary to note the following recommendations:**

- Check the correct direction of rotation of the gear reducer output shaft before fitting the unit to the machine.
- In the case of particularly lengthy periods of storage (4/6 months), if the oil seal is not immersed in the lubricant inside the unit, it is recommended to change it since the rubber could stick to the shaft or may even have lost the elasticity it needs to function properly.
- Whenever possible, protect the gear reducer against solar radiation and bad weather.
- Ensure the motor cools correctly by ensuring good passage of air from the fan side.
- In the case of ambient temperatures  $< -5^{\circ}\text{C}$  or  $> +40^{\circ}\text{C}$  call MOTOVARIO TECHNICAL SERVICE.
- The various parts (pulleys, gear wheels, couplings, shafts, etc.) must be mounted on the solid or hollow shafts using special threaded holes or other systems that anyhow ensure correct operation without risking damage to the bearings or external parts of the units. Lubricate the surfaces in contact to avoid seizure or oxidation.
- Painting must definitely not go over rubber parts and the holes on the breather plugs, if any.
- For units equipped with oil plugs, replace the closed plug used for shipping with the special breather plug.
- Check the correct level of the lubricant through the indicator, if there is one.
- Starting must take place gradually, without immediately applying the maximum load.
- When there are parts, objects or materials under the motor drive that can be damaged by even limited spillage of oil, special protection should be fitted.

Please note: in the event of a cover with adhesive label having to be replaced, you will have to stick a new label onto the new cover. Please contact Motovario and we can supply you with one.

Motovario products are supplied with the following surface treatment features:

**Die-cast aluminium alloy cases for gears (sizes 025-110)**

Die-cast materials undergo the following surface cleaning operations:

- De-burring by means of a mechanically operated shearing system.
- Accurate shot-peening.
- Painting.
- Washing and passivation.

**Grey-coloured cast-iron cases for gears (sizes 130-150)**

- Die-cast materials are always painted.

**Painting specifications:**

- Orange-peel blue epoxy-polyester RAL 5010. Polyester resin based heat-hardening powders, altered with epoxy resins.

**Mechanical properties:** Tests carried out onto degreased Unichim white lattens (film thickness: 60 microns) comply with the following specifications: adherence (ISO2409).

**Heat resistance:** 24 HOURS AT 150°C.

**Corrosion strength:** ASTM B 117/97 salt fog from 100 to 500 hours depending on the support's preliminary treatment.

**Performance:**

- Loading capacity in accordance with: ISO 14521, DIN 3996, BS 721, AGMA 6034, ISO 6336, DIN 3990, DIN 743, ISO 281.

### 2.2.1 Designation

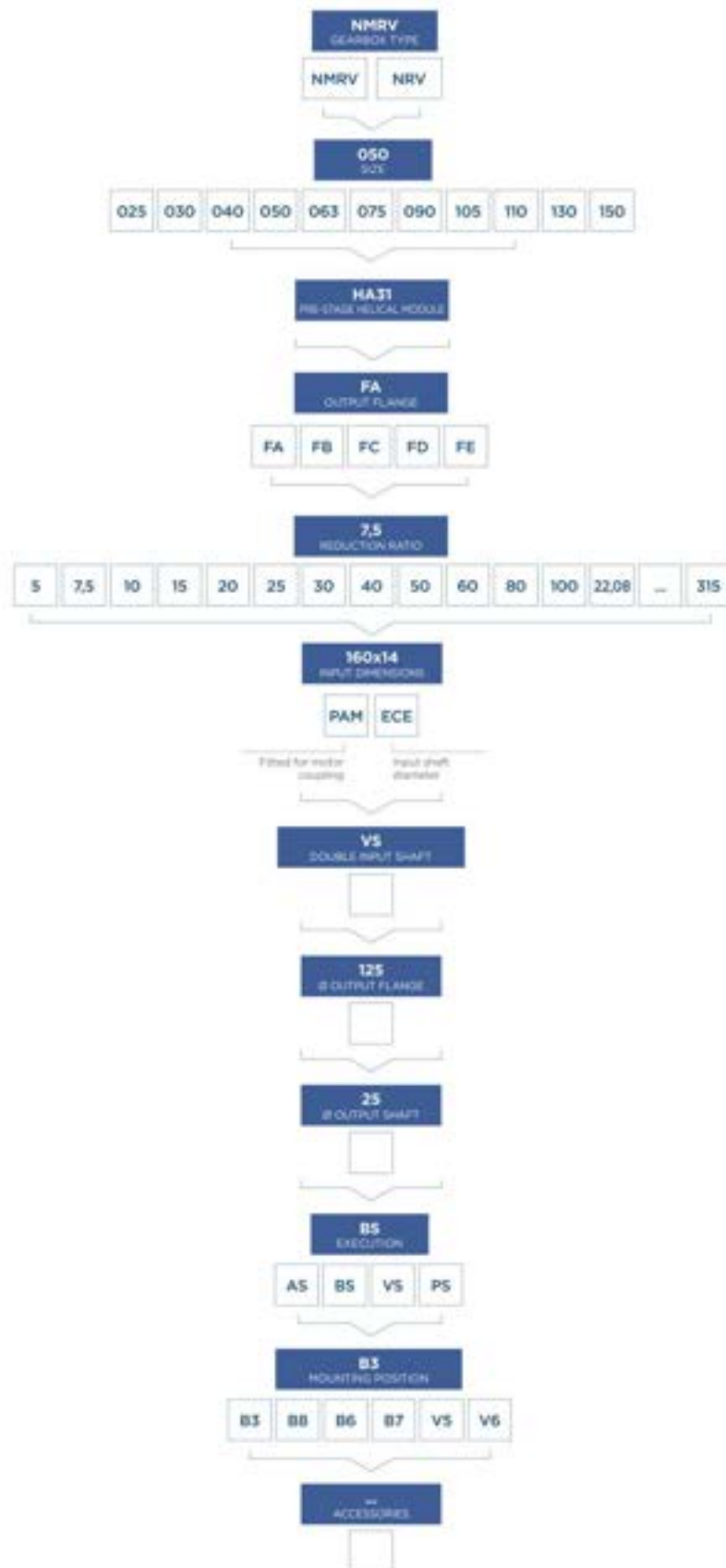

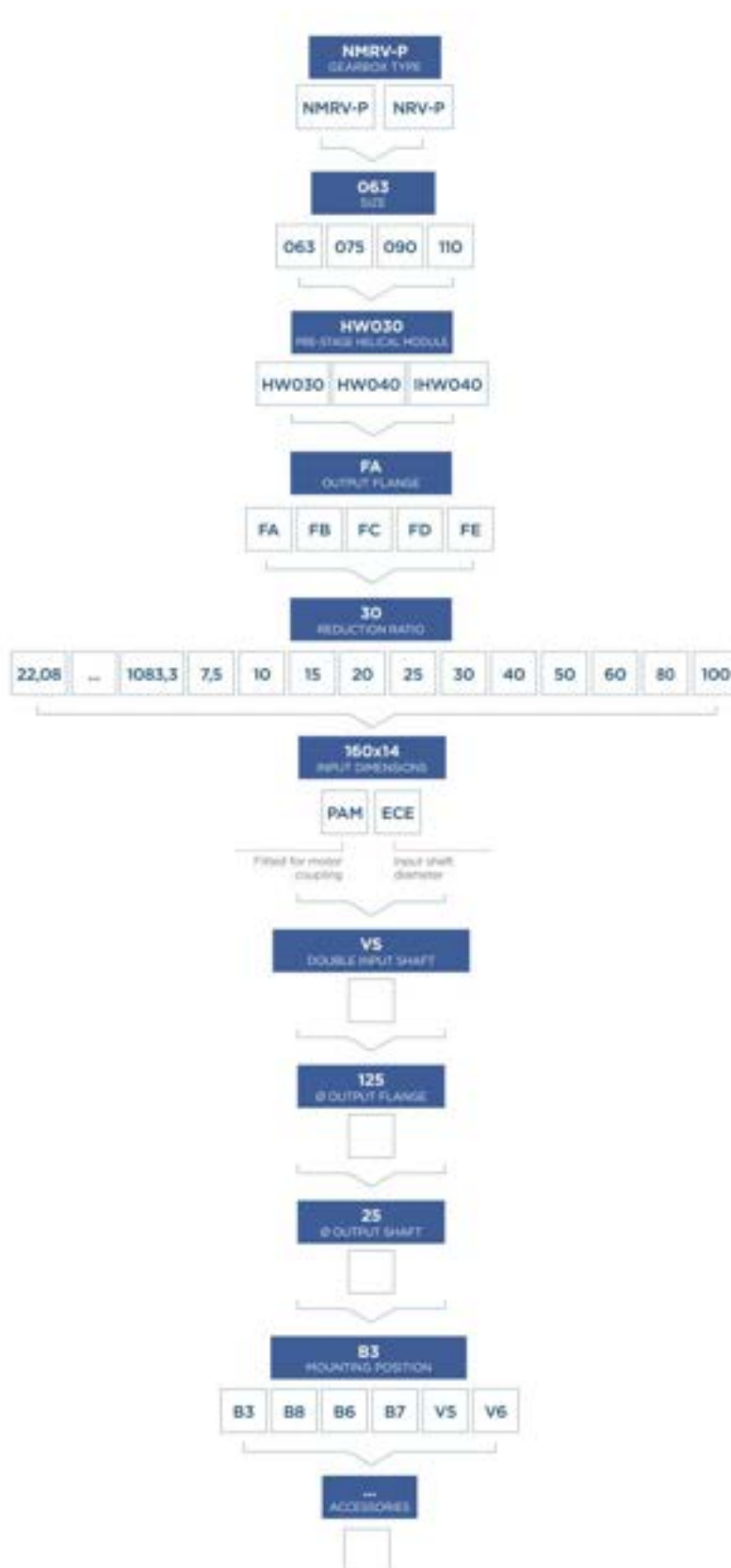



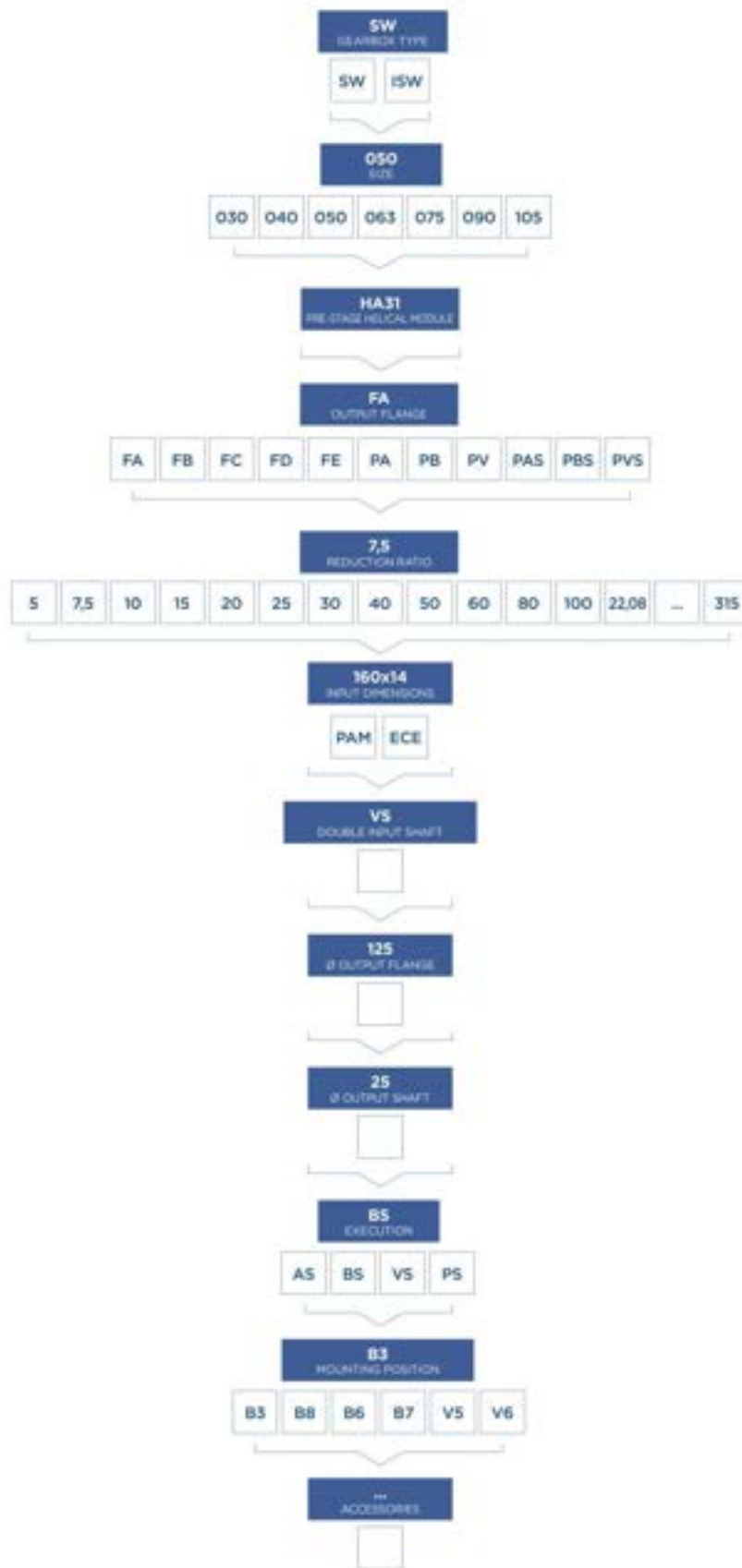







2.2.2 Versions

NMRV

NMRV 025-050 / NMRV 130-150



NMRV 025-050 F / NMRV 130-150 F



NRV 030-050 / NRV 130-150



NRV 030-050 F / NRV 130-150 F



NMRV-NMRV...



NRV-NMRV... F



NRV-NMRV...



NRV-NMRV... F



HA31+NMRV...



HA31+NMRV... F



**NMRVpower**

**NMRVpower 063-110**



**NMRVpower 063-110 F**

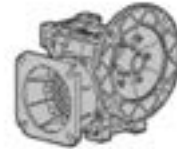

**NRVpower 063-110**



**NRVpower 063-110 F**

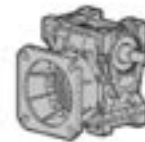

**NMRV-NMRVpower...  
NMRVpower-NMRV...  
NMRVpower-NMRVpower...**



**NMRV-NMRVpower... F  
NMRVpower-NMRV... F  
NMRVpower-NMRVpower... F**



**NRV-NMRVpower...  
NRVpower-NMRV...  
NRVpower-NRVpower...**



**NRV-NMRVpower... F  
NRVpower-NRV... F  
NRVpower-NRVpower...F**



**NMRVpower/HW...**



**NMRVpower/HW... F**

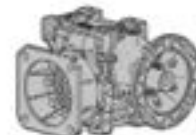

**SW**

**SW 030-105**



**SW 030-105 F**



**ISW 030-105**



**ISW 030-105 F**



**SW 030-105 PA/PAS**



**SW 030-105 PB/PBS**



**SW 030-105 PV/PVS**



**ISW 030-105 PA/PAS**



**ISW 030-105 PB/PBS**



**ISW 030-105 PV/PVS**



**SW-SW  
SW-SW...F  
SW-SW...PA/PAS**



**ISW-SW  
ISW-SW...F  
ISW-SW...PA/PAS**



**HA31-SW | HA31-SW..PA/PAS**



**HA31-SW...F**



2.2.3 Modularity

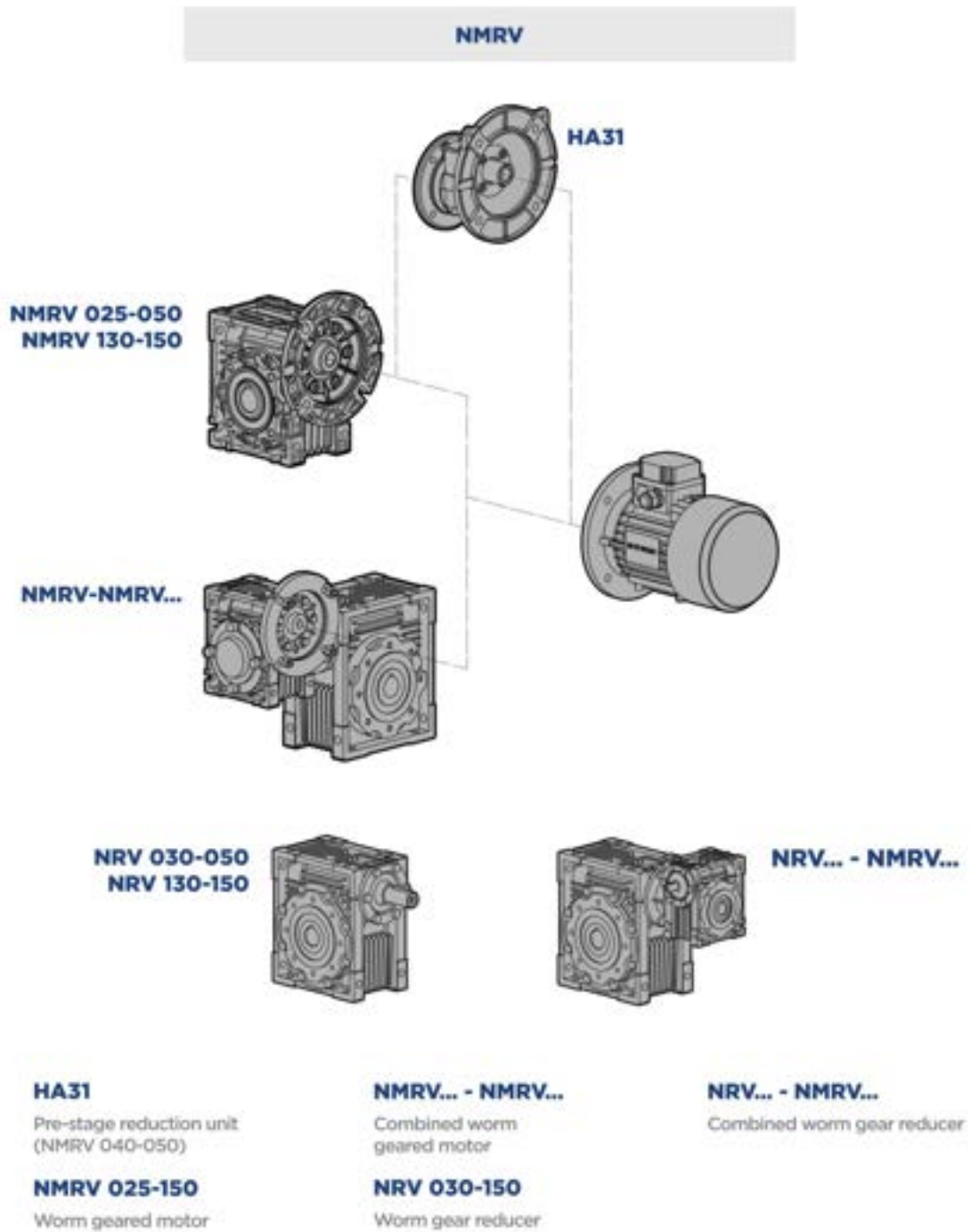

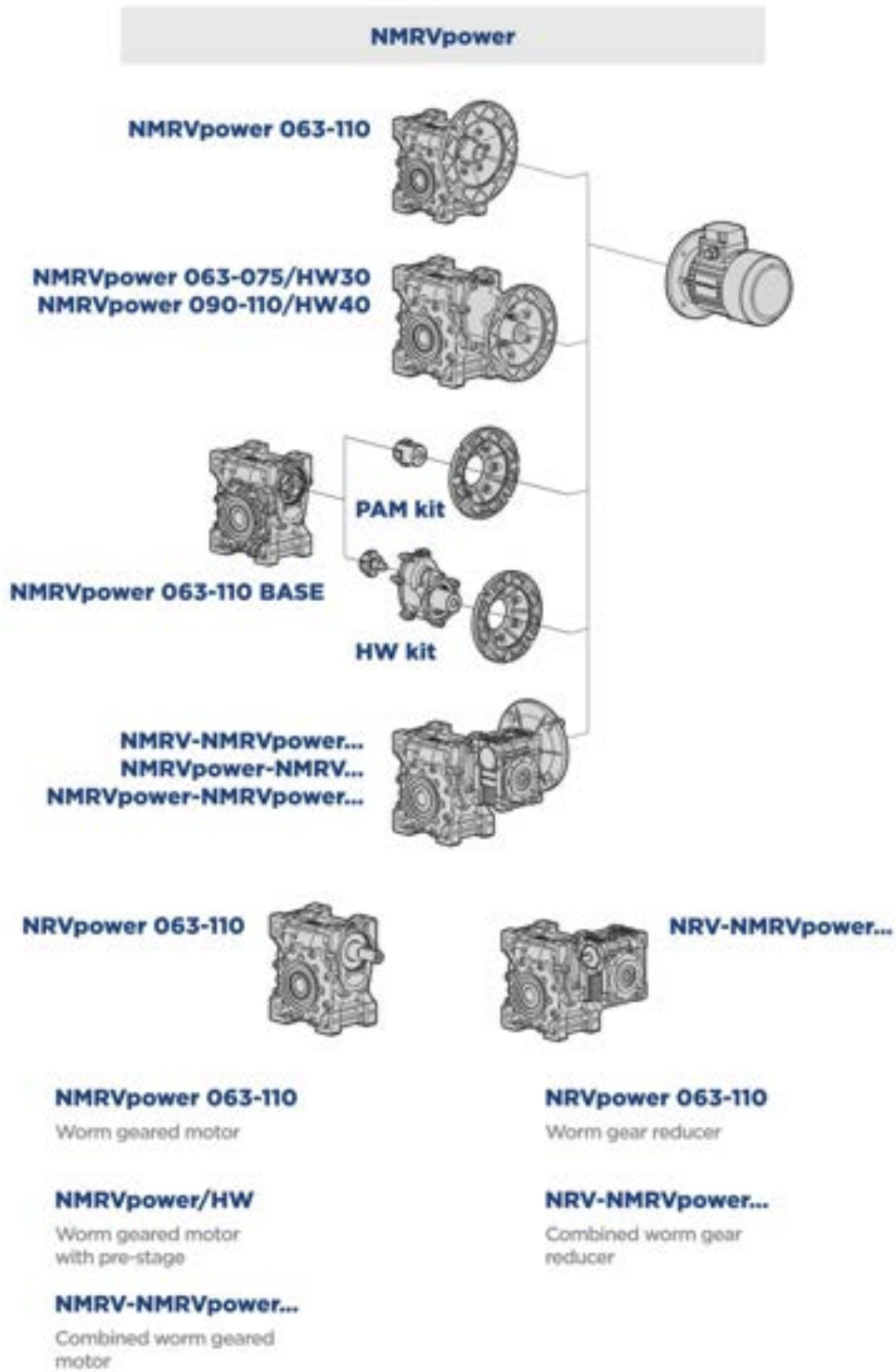

**SW**

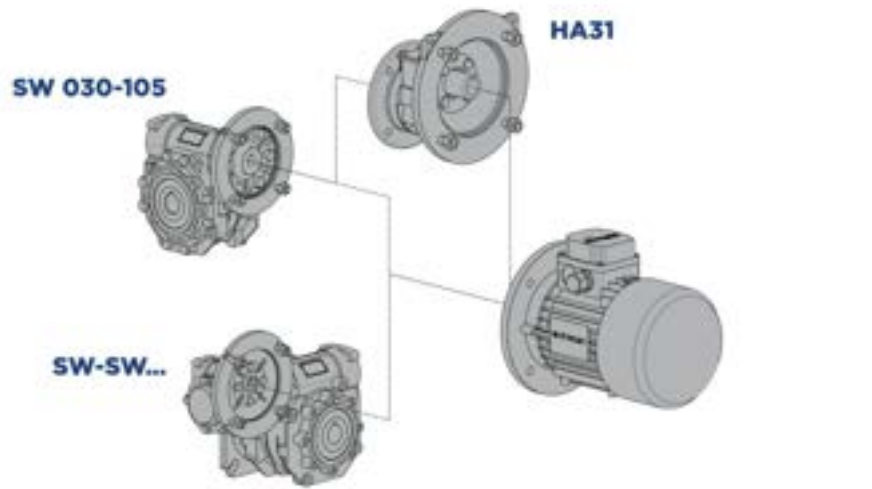

**SW 030-105**

Worm geared motor

**SW-SW...**

Combined worm geared motor

**HA31**

Pre-stage reduction unit



**ISW-SW...**

**ISW 030-105**

Worm gear reducer

**ISW-SW...**

Combined worm gear reducer

### 2.3.1 Mounting positions

The mounting position of the gear unit identifies its space orientation. Unless specified otherwise, the standard positions are B3/BS. B3 mounting position, as from a technical point of view, ensures lower oil splash, better lubrication and less heating. For positions not envisaged, it is necessary to call our Technical Service. "U" version is related to sizes from NMRV/NMRV-P/SW 025-075 and NRV/NRV-P/ISW 030-063. For these sizes it is not necessary to specify mounting position. For NMRV/SW 090-105-110 mounting position B3 is valid also for B6-B7-B8. Mounting positions V5 and V6 must be specified. For NMRV 130-150 mounting positions B3-B6-B7-B8-V5-V6 must be specified.

(\*NMRV-P - HW) Execution only in BS. For NMRV-P/HW mounting position B3 is valid also for B6-B7-B8. Mounting position V5-V6 must be specified.

(\*\*HA31+NMRV/SW) The mounting position is U and it is valid for all mounting positions.

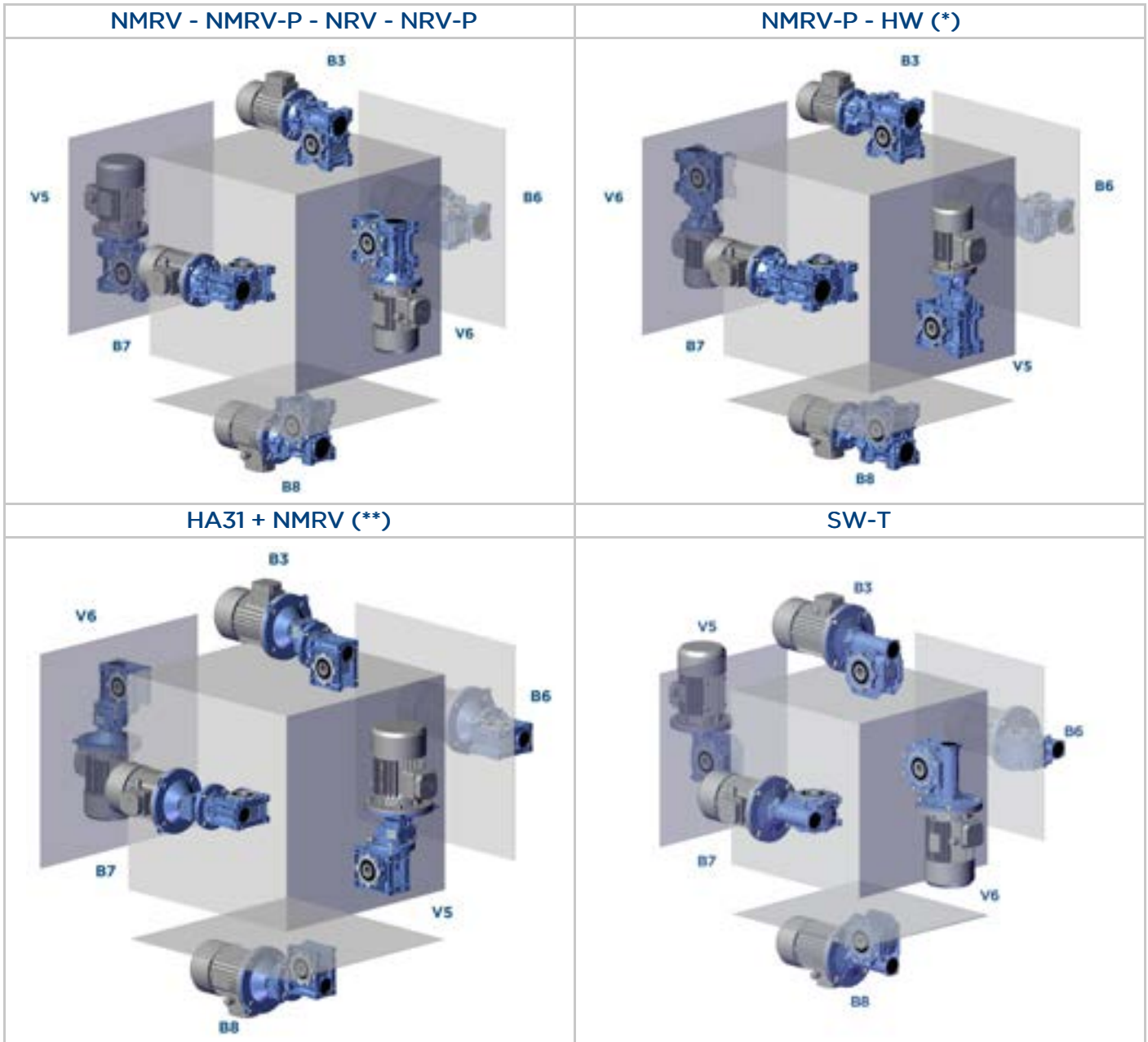

SW-PA/PAS

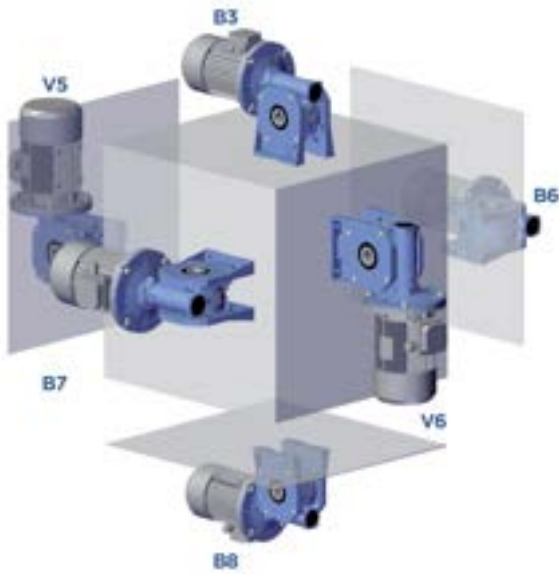

SW-PB/PBS

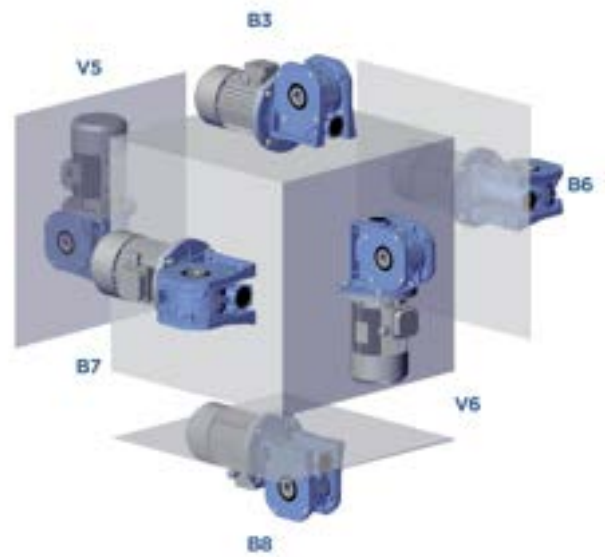

SW-PV/PVS

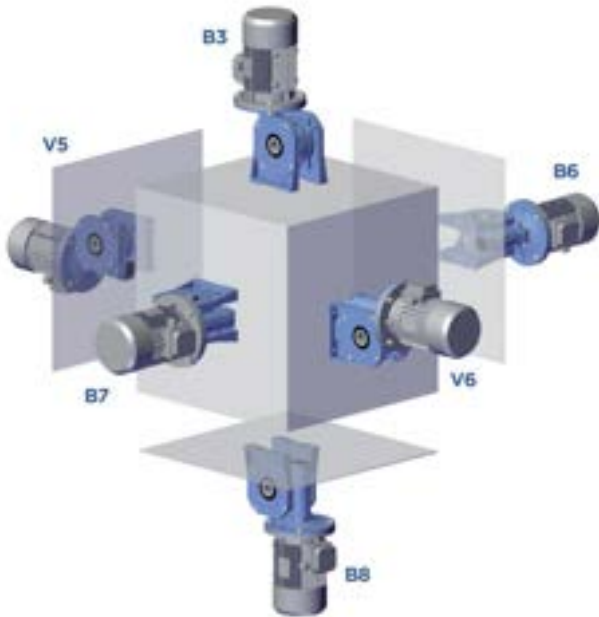

HA31 + SW (\*\*)

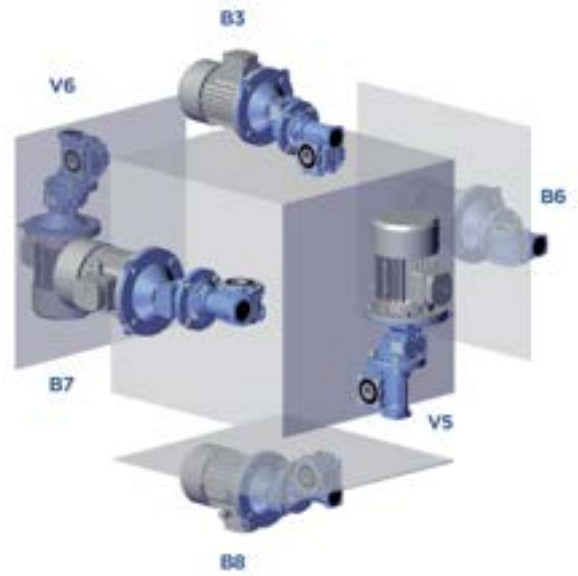



Execution

**NMRV/NMRV-P+NMRV/NMRV-P - NRV/NRV-P+NMRV/NMRV-P**

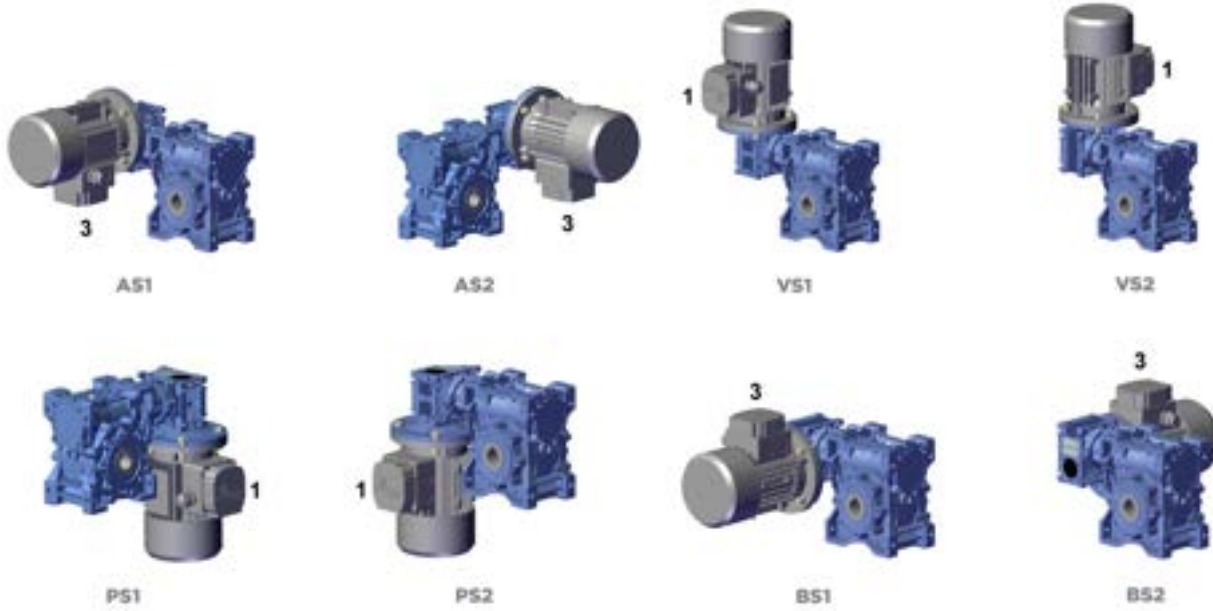

**HA31+NMRV**



Execution

SW+SW - ISW+SW

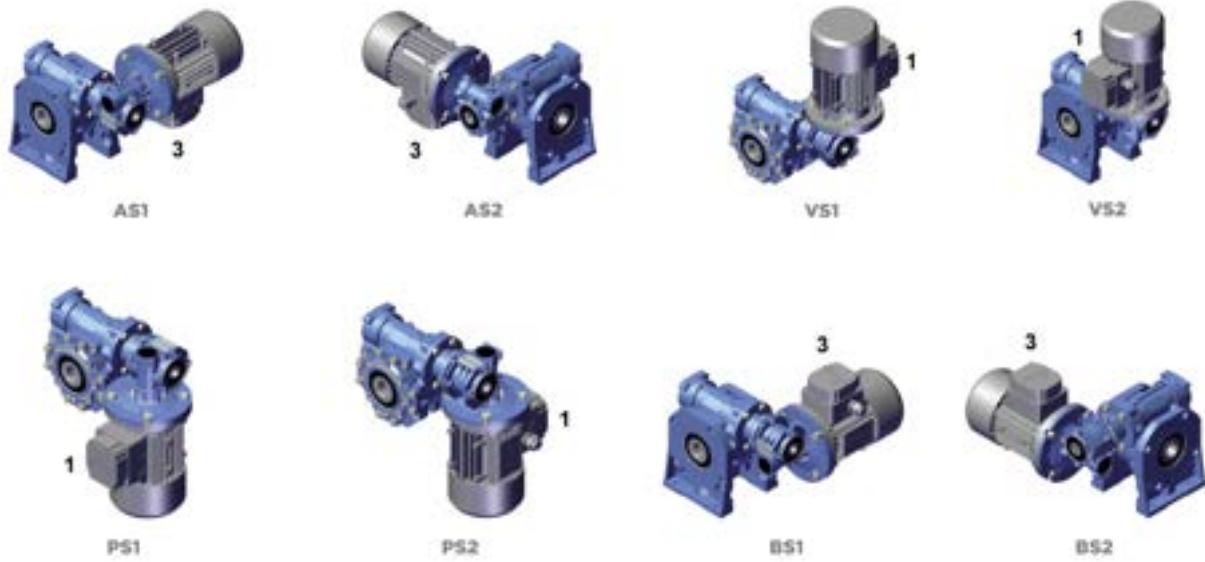

HA31+SW



2.3.2 Position of terminal box

In the case of specific requirements, when ordering, specify the position of the terminal box as shown in the diagram. Unless otherwise specified, the gear reducer is supplied with terminal box in position 1. Terminal box position always refers to HA31 position.

NMRV - NMRV-P - SW

HA31+NMRV/SW

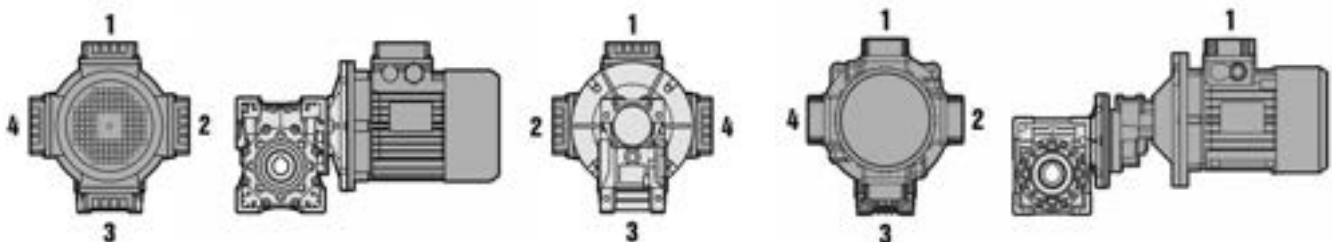

### 2.3.3 Position of terminal box - SW/CD

In the case of specific requirements, when ordering, specify the position of the terminal box as shown in the diagram. Unless otherwise specified, the gear reducer is supplied with terminal box in position 1.

SW-CD/A - SW-CD/C - SW-CD/D

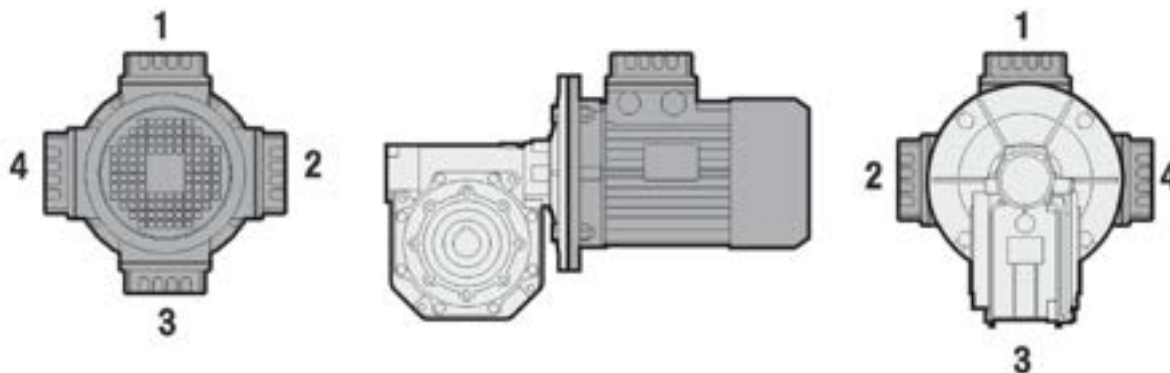

### 2.4.1 Efficiency

Efficiency is a parameter which has a major influence on the sizing of certain applications, and basically depends on gear pair design elements. The mesh data table shows dynamic efficiency ( $n_1=1400$ ) and static efficiency values. These values are only valid after the unit has been run in, is being used at ambient temperatures of 25°C, where service factor is 1 and with standard lubricant.

#### Dynamic irreversibility

Dynamic irreversibility is achieved when the output shaft stops instantly when drive is no longer transmitted through the worm shaft. This condition requires a dynamic efficiency of  $\eta_d < 0.5$ .

#### Static irreversibility

Static irreversibility is achieved when, with the gear reducer at a standstill, the application of a load to the output shaft does not set in motion the worm shaft. This condition requires a static efficiency of  $\eta_s < 0.5$ .

**N.B.: Vibrations and shocks can affect a gear reducer's irreversibility.**

### 2.4.2 Irreversibility

$\eta_d$	DYNAMIC IRREVERSIBILITY
>0.6	dynamic reversibility
0.5÷0.6	low dynamic reversibility
0.4÷0.5	good dynamic irreversibility
<0.4	dynamic irreversibility

$\eta_s$	STATIC IRREVERSIBILITY
>0.55	static reversibility
0.5÷0.55	low static reversibility
<0.5	static irreversibility

The table shows approximate irreversibility classes.

The irreversibility condition of combined gear reducers is given by the units with the lowest efficiency.

	i	5	7,5	10	15	20	25	30	40	50	60	80	100
025	Z1	6	4	3	2	2	-	1	1	1	1	-	-
	Υ	35°02'	25°03'	19°19'	13°09'	10°41'		6°40'	5°23'	4°31'	3°53'		
	Mx	1,3	1,3	1,3	1,3	0,995		1,3	0,995	0,8	0,67		
	ηδ(1400)	0,87	0,85	0,83	0,79	0,75		0,67	0,62	0,58	0,55		
	ηs	0,72	0,71	0,68	0,61	0,56		0,46	0,41	0,36	0,34		
030	Z1	6	4	3	2	2	1	1	1	1	1	1	-
	Υ	27°04'	18°49'	14°20'	9°40'	7°42'	5°35'	4°52'	3°52'	3°12'	2°45'	2°07'	
	Mx	1,44	1,44	1,44	1,44	1,09	1,7	1,44	1,09	0,89	0,74	0,56	
	ηδ(1400)	0,87	0,85	0,83	0,78	0,74	0,69	0,66	0,6	0,56	0,52	0,45	
	ηs	0,72	0,67	0,63	0,55	0,5	0,43	0,39	0,35	0,31	0,27	0,23	
040	Z1	6	4	3	2	2	2	1	1	1	1	1	1
	Υ	34°19'	24°28'	18°51'	12°49'	10°23'	8°43'	6°29'	5°14'	4°23'	3°47'	2°57'	2°25'
	Mx	2,06	2,06	2,06	2,06	1,57	1,27	2,06	1,57	1,27	1,06	0,81	0,65
	ηδ(1400)	0,89	0,87	0,85	0,83	0,79	0,76	0,71	0,66	0,63	0,59	0,53	0,48
	ηs	0,74	0,71	0,67	0,6	0,55	0,51	0,45	0,4	0,36	0,32	0,28	0,24
050	Z1	6	4	3	2	2	2	1	1	1	1	1	1
	Υ	33°37'	23°54'	18°23'	12°30'	10°06'	8°29'	6°19'	5°06'	4°16'	3°40'	2°52'	2°21'
	Mx	2,56	2,56	2,56	2,56	1,95	1,58	2,56	1,95	1,58	1,32	1	0,8
	ηδ(1400)	0,89	0,88	0,87	0,83	0,8	0,77	0,73	0,68	0,64	0,6	0,54	0,5
	ηs	0,74	0,7	0,66	0,59	0,55	0,51	0,44	0,39	0,35	0,32	0,27	0,23
063	Z1	-	4	3	2	2	2	1	1	1	1	1	1
	Υ	-	24°31'	18°53'	12°51'	10°25'	8°45'	6°30'	5°15'	4°24'	3°47'	2°58'	2°26'
	Mx	-	3,25	3,25	3,25	2,48	2	3,25	2,48	2	1,68	1,27	1,02
	ηδ(1400)	-	0,89	0,87	0,84	0,82	0,79	0,75	0,71	0,67	0,63	0,58	0,52
	ηs	-	0,71	0,67	0,6	0,55	0,51	0,45	0,4	0,36	0,33	0,28	0,24
075	Z1	-	4	3	2	2	2	1	1	1	1	1	1
	Υ	-	26°17'	20°20'	13°52'	11°18'	9°32'	7°02'	5°42'	4°48'	4°08'	3°14'	2°40'
	Mx	-	3,94	3,94	3,94	3	2,42	3,94	3	2,42	2,03	1,54	1,24
	ηδ(1400)	-	0,89	0,88	0,86	0,83	0,81	0,77	0,73	0,7	0,66	0,61	0,56
	ηs	-	0,71	0,68	0,61	0,57	0,53	0,46	0,42	0,38	0,35	0,29	0,26
090	Z1	-	4	3	2	2	2	1	1	1	1	1	1
	Υ	-	29°11'	22°44'	15°36'	12°50'	10°54'	7°57'	6°30'	5°30'	4°46'	3°45'	3°06'
	Mx	-	4,84	4,84	4,84	3,69	2,98	4,84	3,69	2,98	2,5	1,89	1,52
	ηδ(1400)	-	0,9	0,89	0,87	0,85	0,83	0,79	0,76	0,73	0,7	0,64	0,6
	ηs	-	0,73	0,7	0,64	0,6	0,56	0,49	0,45	0,41	0,38	0,32	0,28
105	Z1	-	4	3	2	2	2	1	1	1	1	1	1
	Υ	-	28°15'	21°57'	15°02'	14°41'	12°34'	7°39'	7°28'	6°22'	5°32'	4°24'	3°39'
	Mx	-	5,875	5,875	5,875	4,62	3,73	5,875	4,62	3,73	3,13	2,37	1,91
	ηδ(1400)	-	0,9	0,89	0,87	0,86	0,85	0,8	0,79	0,76	0,73	0,68	0,64
	ηs	-	0,72	0,69	0,63	0,62	0,59	0,48	0,48	0,44	0,41	0,36	0,32
130	Z1	-	4	3	2	2	2	1	1	1	1	1	1
	Υ	-	28°41'	22°19'	15°18'	13°52'	11°49'	7°47'	7°02'	5°58'	5°11'	4°07'	3°24'
	Mx	-	6,97	6,97	6,97	5,4	4,37	6,97	5,4	4,37	3,67	2,77	2,23
	ηδ(1400)	-	0,91	0,89	0,87	0,87	0,85	0,81	0,79	0,76	0,73	0,69	0,65
	ηs	-	0,72	0,69	0,63	0,61	0,58	0,49	0,46	0,43	0,39	0,34	0,3
150	Z1	-	6	4	3	2	2	2	1	1	1	1	1
	Υ	-	32°09'	24°35'	17°27'	12°53'	11°19'	9°50'	6°32'	5°43'	4°57'	3°55'	3°14'
	Mx	-	5,5	6,155	5,5	6,155	5	4,193	6,155	5	4,193	3,17	2,55
	ηδ(1400)	-	0,91	0,9	0,88	0,87	0,85	0,84	0,79	0,77	0,74	0,69	0,65
	ηs	-	0,73	0,71	0,66	0,6	0,57	0,54	0,45	0,42	0,39	0,33	0,29

These values can be detected on the output shaft, with the input shaft locked. For applications requiring controlled or reduced backlash, please contact our technical department.

<b>NMRV 030</b>	<b>NMRV 040</b>	<b>NMRV 050</b>	<b>NMRV-P 063</b>	<b>NMRV-P 075</b>	<b>NMRV-P 90</b>	<b>NMRV-P 110</b>	<b>NMRV 130</b>	<b>NMRV 150</b>
20' - 44'	18' - 34'	18' - 32'	18' - 28'	16' - 24'	6' - 18'	6' - 14'	6' - 12'	6' - 12'

  

<b>SW 030</b>	<b>SW 040</b>	<b>SW 050</b>	<b>SW 063</b>	<b>SW 075</b>	<b>SW 090</b>	<b>SW 105</b>
20' - 44'	18' - 34'	18' - 32'	18' - 28'	16' - 24'	6' - 18'	6' - 14'

### 2.7.1 Direction of rotation

The worm screw rotation is right-handed.

#### DIRECTION OF ROTATION - HIGH SPEED SHAFT

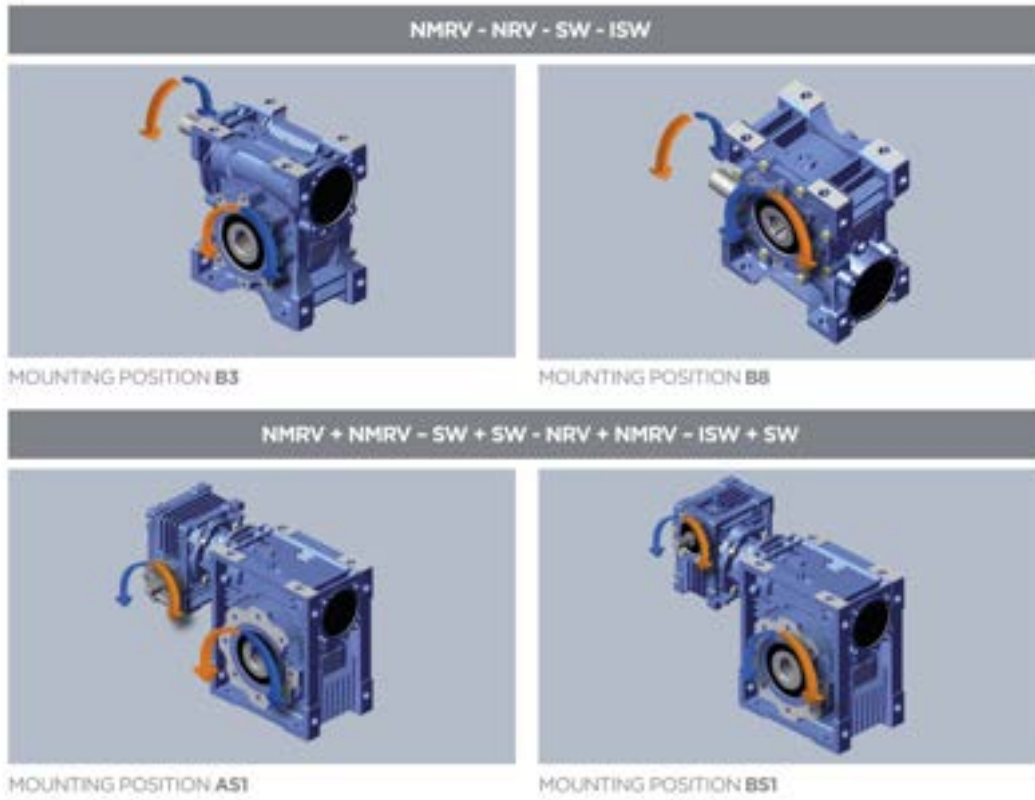

### 2.7.2 Direction of rotation - SW/CD

The worm screw rotation is right-handed.

#### DIRECTION OF ROTATION - HIGH SPEED SHAFT

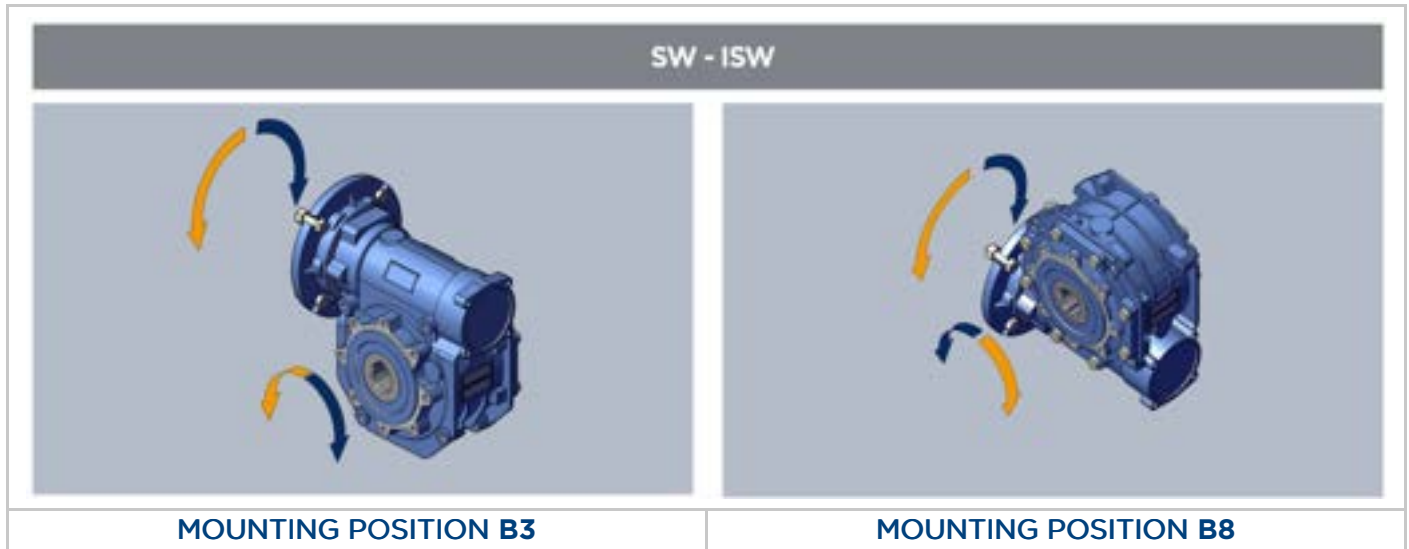



## 2.8.1 Critical applications

NMRV - NMRV-P	NMRV				NMRV-P				NMRV	
	025	030	040	050	063	075	090	110	130	150
V5: 1500 < n1 < 3000	✓	✓	✓	✓	B	B	B	B	B	B
n1 > 3000	B	B	B	B	B	B	A	A	A	A
V6	B	B	B	B	B	B	B	B	B	B

SW	030	040	050	063	075	090	105
V5: 1500 < n1 < 3000	✓	✓	✓	✓	B	B	B
n1 > 3000	B	B	B	B	A	A	A
V6	B	B	B	B	B	B	B

H	A31	HW+NMRV-P	030+063	030+075	040+090	040+110
V5 - V1: 1500 < n1 < 3000	✓	1500<n1<3000	B	B	B	B
n1 > 3000	B	n1>3000	A	A	A	A
V3 - V6	B	V5 - V6	B	B	B	B

✓ Verified application

A Application not recommended

B Check the application and/or call MOTOVARIO TECHNICAL SERVICE.

## 2.8.2 Information

The performance given in the catalogue correspond to mounting position B3 or similar, when the first stage is not entirely immersed in oil. For other mounting positions and/or particular input speeds, refer to the tables that highlight different critical situations for each size of gear reducer. It is also necessary to take due consideration of and carefully assess the following applications by calling MOTOVARIO TECHNICAL SERVICE:

- To avoid the use as multiplier.
- Use in services that could be hazardous for people if the gear reducer fails.
- Applications with especially high inertia.
- Use as a lifting winch.
- Applications with high dynamic strain on the case of the gear reducer.
- In places with  $T_{amb}$  under  $-5^{\circ}\text{C}$  or over  $40^{\circ}\text{C}$ .
- Use in chemically aggressive environments.
- Use in a salty environment.
- Mounting positions not envisaged in the catalogue.
- Use in radioactive environments.
- Use in environments pressures other than atmospheric pressure.

Avoid applications where even partial immersion of the reducer is required.

In the presence of overloading due to full load, braking, shocks or other static and dynamic causes, please verify that the peak torque is less than  $2 \cdot M_{n2}$ .

2.9.1 NMRV - NMRV-P Motor flange availability

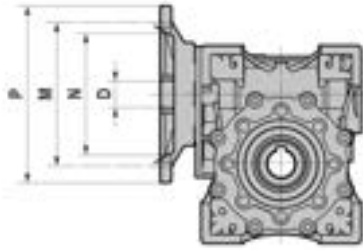

- (\*) Low profile key supplied by Motovario.
- (•) Motor-ratio combination feasible.
- (\*\*) Motor-ratio combination not feasible.
- (+) Motor-ratio combination not to be used, out of warranty terms.

The table report possible configurations strictly based on geometric criteria. To determine the compatibility of a motor-gear unit assembly in terms of mechanical factors, double check the selected configuration against the rating charts for NRV/NRV-P performances.

NMRV NMRV-P	PAM IEC	N	M	P	D	i											
						5	7,5	10	15	20	25	30	40	50	60	80	100
025	56B14	50	65	80	9	•	•	•	•	•	**	•	•	•	•	**	**
	63B5	95	115	140	11	•	•	•	•	•	•	•	•	•	**	**	**
030	63B14	60	75	90	11	•	•	•	•	•	•	•	•	•	**	**	**
	56B5	80	100	120	9	•	•	•	•	•	•	•	•	•	•	•	**
040	56B14	50	65	80	9	•	•	•	•	•	•	•	•	•	•	•	**
	71B5	110	130	160	14	•	•	•	•	•	•	•	•	**	**	**	**
040	71B14	70	85	105	14	•	•	•	•	•	•	•	•	•	•	•	•
	63B5	95	115	140	11	•	•	•	•	•	•	•	•	•	•	•	•
050	63B14	60	75	90	11	•	•	•	•	•	•	•	•	•	•	•	•
	56B5	80	100	120	9	**	**	**	**	**	**	**	**	•	•	•	•
050	80B5	130	165	200	19	•	•	•	•	•	•	•	**	**	**	**	**
	80B14	80	100	120	19	•	•	•	•	•	•	•	**	**	**	**	**
050	71B5	110	130	160	14	•	•	•	•	•	•	•	•	•	•	•	**
	71B14	70	85	105	14	•	•	•	•	•	•	•	•	•	•	•	**
063	63B5	95	115	140	11	**	**	**	**	**	**	**	•	•	•	•	•
	90B5	130	165	200	24	**	•	•	•	•	•	•	•	+	+	+	+
063	90B14	95	115	140	24	**	•	•	•	•	•	•	•	+	+	+	+
	80B5	130	165	200	19	**	•	•	•	•	•	•	•	•	•	•	+
063	80B14	80	100	120	19	**	•	•	•	•	•	•	•	•	•	•	•
	71B5	110	130	160	14	**	•	•	•	•	•	•	•	•	•	•	•
075	71B14	70	85	105	14	**	•	•	•	•	•	•	•	•	•	•	•
	100/112B5	180	215	250	28	**	•	•	•	•	•	•	•	+	+	+	+
075	100/112B14	110	130	160	28	**	•	•	•	•	•	•	•	+	+	+	+
	90B5	130	165	200	24	**	•	•	•	•	•	•	•	•	•	+	+
075	90B14	95	115	140	24	**	•	•	•	•	•	•	•	•	•	•	•
	80B5	130	165	200	19	**	•	•	•	•	•	•	•	•	•	•	•
090	80B14	80	100	120	19	**	•	•	•	•	•	•	•	•	•	•	•
	71B5	110	130	160	14	**	•	•	•	•	•	•	•	•	•	•	•
090	71B14	70	85	105	14	**	•	•	•	•	•	•	•	•	•	•	•
	100/112B5	180	215	250	28	**	•	•	•	•	•	•	•	+	+	+	+
090	100/112B14	110	130	160	28	**	•	•	•	•	•	•	•	+	+	+	+
	90B5	130	165	200	24	**	•	•	•	•	•	•	•	•	•	•	+
110	90B14	95	115	140	24	**	•	•	•	•	•	•	•	•	•	•	•
	80B5	130	165	200	19	**	•	•	•	•	•	•	•	•	•	•	•
110	80B14	80	100	120	19	**	•	•	•	•	•	•	•	•	•	•	•
	132B5	230	265	300	38	**	•*	•*	•*	•*	•*	•*	•*	**	**	**	**
130	100/112B5	180	215	250	28	**	**	**	**	**	•	•	•	•	•	•	•
	90B5	130	165	200	24	**	**	**	**	**	**	**	**	**	**	•	•
150	160B5	250	300	350	42	**	•	•	•	•	•	**	**	**	**	**	**
	132B5	230	265	300	38	**	**	**	**	•	•	•	•	•	•	**	**
150	100/112B5	180	215	250	28	**	**	**	**	**	**	**	**	•	•	•	•

2.9.2 NMRV - NMRV-P HYBRID Motor flange availability

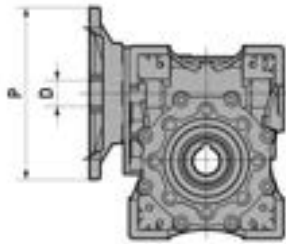

- (\*) Low profile key supplied by Motovario.
- (\*\*) For NMRV-P 110 flange Ø300 only possible solution bush Ø38.
- (+) Motor-ratio combination not to be used, out of warranty terms.

The table report possible configurations strictly based on geometric criteria. To determine the compatibility of a motor-gear unit assembly in terms of mechanical factors, double check the selected configuration against the rating charts for NRV/NRV-P performances.

NMRV NMRV-P	P	i											
		5	7.5	10	15	20	25	30	40	50	60	80	100
D													
025	80	9	9	9	9	9	-	9	9	9	9	-	-
030	140												
	120	11	11	11	11	11	11	11	11	11	9	9	-
	90	9	9	9	9	9	9	9	9	9	9	9	-
040	80												
	160												
	140												
	120	14	14	14	14	14	14	14	14	14	11	11	11
050	105	11	11	11	11	11	11	11	11	11	9	9	9
	90												
	200												
	160	19	19	19	19	19	19	19	14	14	14	14	11
	140	14	14	14	14	14	14	14	11	11	11	11	11
063	120												
	105												
	200												
	160		24	24	24	24	24	24	24	19	19	19	14
	140	-	19	19	19	19	19	19	19	14	14	14	14
075	120												
	105												
	250												
	200												
	160	-	28	28	28	28	28	28	24	24	24	19	19
	140		24	24	24	24	24	24	19	19	19	14	14
090	120												
	105												
	250												
	200												
	160	-	28	28	28	28	28	28	28	24	24	24	19
110	140												
	120												
	300		38**	38**	38**	38**	38**	38**	38**	+	+	+	+
	250												
	200												
130	160												
	200												
	250												
	300	-	38*	38*	38*	38*	38*	38*	38*	28	28	28	28
150	350												
	300												
	250	-	42	42	42	42	42	38	38	38	38	28	28

2.9.3 HA31+NMRV Motor flange availability

HA31	NMRV 040	flx12	63	71	80
2,94	7,5	22,08	B5	B5	B5
4,75	5	23,75	B5	B5	B5
5,10	5	25,50	B5	B5	
2,94	10	29,44	B5	B5	
6,30	5	31,50	B5	B5	
4,75	7,5	35,63	B5	B5	
5,45	7,5	40,91	B5	B5	
2,94	15	44,17	B5	B5	
4,75	10	47,50	B5	B5	
5,45	10	54,55	B5	B5	
2,94	20	58,89	B5	B5	
6,30	10	63,00	B5	B5	
4,75	15	71,25	B5	B5	
7,88	10	78,75	B5		
2,94	30	88,33	B5		
6,30	15	94,50	B5		
5,10	20	102,00	B5		
5,45	20	109,09	B5		
7,88	15	118,13	B5		
5,10	25	127,50	B5		
4,75	30	142,50	B5		
3,87	40	154,67	B5		
5,45	30	163,64	B5		
6,30	30	189,00	B5		
5,10	40	204,00	B5		

HA31	NMRV 050	flx12	63	71	80
2,94	7,5	22,08		B5	B5
4,75	5	23,75	B5	B5	B5
5,10	5	25,50	B5	B5	
2,94	10	29,44	B5	B5	B5
6,30	5	31,50	B5	B5	
4,75	7,5	35,63	B5	B5	B5
5,45	7,5	40,91	B5	B5	
2,94	15	44,17	B5	B5	B5
4,75	10	47,50	B5	B5	B5
5,45	10	54,55	B5	B5	
2,94	20	58,89	B5	B5	
6,30	10	63,00	B5	B5	
4,75	15	71,25	B5	B5	
7,88	10	78,75	B5	B5	
2,94	30	88,33	B5	B5	
6,30	15	94,50	B5	B5	
5,10	20	102,00	B5	B5	
5,45	20	109,09	B5	B5	
7,88	15	118,13	B5	B5	
5,10	25	127,50	B5	B5	
4,75	30	142,50	B5	B5	
3,87	40	154,67	B5	B5	
5,45	30	163,64	B5	B5	
6,30	30	189,00	B5		
5,10	40	204,00	B5		
7,88	30	236,25	B5		
6,30	40	252,00	B5		
5,45	50	272,73	B5		
4,75	60	285,00	B5		
6,30	50	315,00	B5		

2.9.4 NMRV-P/HW Motor flange availability

HW030	NMRV-P 063	i/xi2	56	63	71	80
2,94	7,5	22,08			B5-B14	B5-B14
3,87	7,5	29,00			B5-B14	B5-B14
3,87	10	38,67			B5-B14	B5-B14
2,94	15	44,17			B5-B14	B5-B14
4,75	10	47,50		B5	B5-B14	B5-B14
3,87	15	58,00		B5	B5-B14	B5-B14
4,75	15	71,25		B5	B5-B14	B5-B14
3,87	20	77,33		B5	B5-B14	B5-B14
5,45	15	81,82		B5	B5-B14	B5-B14
2,94	30	88,33		B5	B5-B14	B5-B14
4,75	20	95,00		B5	B5-B14	B5-B14
5,45	20	109,09		B5	B5-B14	B5-B14
7,88	15	118,13		B5	B5-B14	B5-B14
5,45	25	136,36		B5	B5-B14	B5-B14
4,75	30	142,50		B5	B5-B14	B5-B14
7,88	20	157,50		B5	B5-B14	B5-B14
5,45	30	163,64		B5	B5-B14	B5-B14
2,94	60	176,67	B5	B5	B5-B14	
7,88	25	196,88	B5	B5	B5-B14	
5,45	40	218,18	B5	B5	B5-B14	
7,88	30	236,25	B5	B5	B5-B14	
5,45	50	272,73	B5	B5	B5-B14	
7,88	40	315,00	B5	B5	B5-B14	
7,88	50	393,75	B5	B5	B5-B14	
10,83	40	433,33	B5	B5		
7,88	60	472,50	B5	B5		
10,83	50	541,67	B5	B5		
10,83	60	650,00	B5	B5		
7,88	100	787,50	B5			
10,83	80	866,67	B5			
10,83	100	1083,33	B5			

HW030	NMRV-P 075	i	56	63	71	80
2,94	7,5	22,08				B5-B14
3,87	7,5	29,00			B5-B14	B5-B14
3,87	10	38,67			B5-B14	B5-B14
2,94	15	44,17			B5-B14	B5-B14
4,75	10	47,50			B5-B14	B5-B14
3,87	15	58,00			B5-B14	B5-B14
4,75	15	71,25			B5-B14	B5-B14
3,87	20	77,33			B5-B14	B5-B14
5,45	15	81,82		B5	B5-B14	B5-B14
2,94	30	88,33		B5	B5-B14	B5-B14
4,75	20	95,00		B5	B5-B14	B5-B14
5,45	20	109,09		B5	B5-B14	B5-B14
3,87	30	116,00		B5	B5-B14	B5-B14
5,45	25	136,36		B5	B5-B14	B5-B14
4,75	30	142,50		B5	B5-B14	B5-B14
3,87	40	154,67		B5	B5-B14	B5-B14
5,45	30	163,64		B5	B5-B14	B5-B14
2,94	60	176,67		B5	B5-B14	B5-B14
7,88	25	196,88		B5	B5-B14	B5-B14
5,45	40	218,18		B5	B5-B14	B5-B14
7,88	30	236,25		B5	B5-B14	B5-B14
5,45	50	272,73		B5	B5-B14	B5-B14
7,88	40	315,00		B5	B5-B14	
7,88	50	393,75	B5	B5	B5-B14	
7,88	60	472,50	B5	B5	B5-B14	
10,83	50	541,67	B5	B5		
10,83	60	650,00	B5	B5		
7,88	100	787,50	B5	B5		
10,83	80	866,67	B5	B5		
10,83	100	1083,33	B5			

HW040	NMRV-P 090	i	63	71	80	90
3,11	7,5	23,29			B5-B14	B5-B14
3,11	10	31,05			B5-B14	B5-B14
4,20	10	42,00			B5-B14	B5-B14
3,11	15	46,58			B5-B14	B5-B14
4,20	15	63,00		B5-B14	B5-B14	B5-B14
3,11	25	77,63		B5-B14	B5-B14	B5-B14
4,20	20	84,00		B5-B14	B5-B14	B5-B14
3,11	30	93,16		B5-B14	B5-B14	B5-B14
5,50	20	110,00		B5-B14	B5-B14	B5-B14
4,20	30	126,00		B5-B14	B5-B14	B5-B14
5,50	25	137,50		B5-B14	B5-B14	B5-B14
3,11	50	155,26	B5	B5-B14	B5-B14	B5-B14
5,50	30	165,00		B5-B14	B5-B14	B5-B14
3,11	60	186,32	B5	B5-B14	B5-B14	
5,50	40	220,00	B5	B5-B14	B5-B14	B5-B14
4,20	60	252,00	B5	B5-B14	B5-B14	
5,50	50	275,00	B5	B5-B14	B5-B14	
6,09	50	304,55	B5	B5-B14	B5-B14	
5,50	60	330,00	B5	B5-B14	B5-B14	
7,67	50	383,33	B5	B5-B14	B5-B14	
8,75	50	437,50	B5	B5-B14		
7,67	60	460,00	B5	B5-B14		
8,75	60	525,00	B5	B5-B14		
7,67	80	613,33	B5	B5-B14		
8,75	80	700,00	B5	B5-B14		
7,67	100	766,67	B5			
8,75	100	875,00	B5			

HW040	NMRV-P 110	i	63	71	80	90
3,11	7,5	23,29			B5-B14	B5-B14
3,11	10	31,05			B5-B14	B5-B14
4,20	10	42,00			B5-B14	B5-B14
3,11	15	46,58			B5-B14	B5-B14
3,105	20	62,11			B5-B14	B5-B14
3,11	25	77,63			B5-B14	B5-B14
4,20	20	84,00			B5-B14	B5-B14
3,11	30	93,16			B5-B14	B5-B14
4,200	25	105,00			B5-B14	B5-B14
4,20	30	126,00			B5-B14	B5-B14
5,50	25	137,50		B5-B14	B5-B14	B5-B14
3,11	50	155,26		B5-B14	B5-B14	B5-B14
4,200	40	168,00		B5-B14	B5-B14	B5-B14
3,11	60	186,32		B5-B14	B5-B14	B5-B14
5,50	40	220,00		B5-B14	B5-B14	B5-B14
4,20	60	252,00		B5-B14	B5-B14	B5-B14
5,50	50	275,00		B5-B14	B5-B14	B5-B14
6,09	50	304,55	B5	B5-B14	B5-B14	B5-B14
5,50	60	330,00	B5	B5-B14	B5-B14	
7,67	50	383,33	B5	B5-B14	B5-B14	
5,500	80	440,00	B5	B5-B14	B5-B14	
7,67	60	460,00	B5	B5-B14	B5-B14	
8,75	60	525,00	B5	B5-B14		
7,67	80	613,33	B5	B5-B14	B5-B14	
8,75	80	700,00	B5	B5-B14		
7,67	100	766,67	B5	B5-B14		
8,75	100	875,00	B5	B5-B14		

2.9.5 SW Motor flange availability

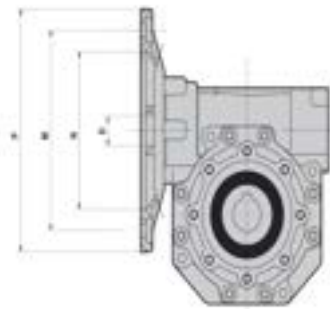

- (\*) Low profile key supplied by Motovario.
- (•) Motor-ratio combination feasible.
- (\*\*) Motor-ratio combination not feasible.
- (+) Motor-ratio combination not to be used, out of warranty terms.

The table report possible configurations strictly based on geometric criteria. To determine the compatibility of a motor-gear unit assembly in terms of mechanical factors, double check the selected configuration against the rating charts for SW/ISW performances.

SW	PAM IEC	N	M	P	D	i											
						5	7,5	10	15	20	25	30	40	50	60	80	100
030	63B5	95	115	140	11	•	•	•	•	•	•	•	•	•	**	**	**
	63B14	60	75	90	11	•	•	•	•	•	•	•	•	•	•	•	•
	56B5	80	100	120	9	•	•	•	•	•	•	•	•	•	•	•	**
	56B14	50	65	80	9	•	•	•	•	•	•	•	•	•	•	•	•
040	71B5	110	130	160	14	•	•	•	•	•	•	•	•	**	**	**	**
	71B14	70	85	105	14	•	•	•	•	•	•	•	•	•	•	•	•
	63B5	95	115	140	11	•	•	•	•	•	•	•	•	•	•	•	•
	63B14	60	75	90	11	•	•	•	•	•	•	•	•	•	•	•	•
050	56B5	80	100	120	9	**	**	**	**	**	**	**	**	•	•	•	•
	80B5	130	165	200	19	•	•	•	•	•	•	•	**	**	**	**	**
	80B14	80	100	120	19	•	•	•	•	•	•	•	•	•	•	•	•
	71B5	110	130	160	14	•	•	•	•	•	•	•	•	•	•	•	**
063	71B14	70	85	105	14	•	•	•	•	•	•	•	•	•	•	•	•
	63B5	95	115	140	11	**	**	**	**	**	**	**	•	•	•	•	•
	90B5	130	165	200	24	**	•	•	•	•	•	•	•	+	+	+	+
	90B14	95	115	140	24	**	•	•	•	•	•	•	•	**	**	**	**
	80B5	130	165	200	19	**	•	•	•	•	•	•	•	**	**	**	**
	80B14	80	100	120	19	**	•	•	•	•	•	•	•	**	**	**	**
075	71B5	110	130	160	14	**	**	**	**	**	**	**	•	•	•	•	•
	71B14	70	85	105	14	**	**	**	**	**	**	**	•	•	•	•	•
	100/112B5	180	215	250	28	**	•	•	•	**	**	**	**	**	**	**	**
	100/112B14	110	130	160	28	**	•	•	•	**	**	**	**	**	**	**	**
	90B5	130	165	200	24	**	•	•	•	•	•	•	•	**	**	**	**
	90B14	95	115	140	24	**	•	•	•	•	•	•	•	**	**	**	**
	80B5	130	165	200	19	**	**	**	**	•	•	•	•	•	•	•	•
090	80B14	80	100	120	19	**	**	**	**	**	**	**	•	•	•	•	•
	100/112B5	180	215	250	28	**	•	•	•	•	•	•	**	**	**	**	**
	100/112B14	110	130	160	28	**	•	•	•	•	•	•	**	**	**	**	**
	90B5	130	165	200	24	**	•	•	•	•	•	•	•	•	•	**	**
	90B14	95	115	140	24	**	•	•	•	•	•	•	•	•	•	**	**
	80B5	130	165	200	19	**	**	**	**	**	**	**	•	•	•	•	•
105	80B14	80	100	120	19	**	**	**	**	**	**	**	•	•	•	•	•
	132B5	230	265	300	38	**	•*	•*	•*	•*	**	**	**	**	**	**	**
	100/112B5	180	215	250	28	**	•	•	•	•	•	•	•	•	•	**	**
	90B5	130	165	200	24	**	**	**	**	**	•	•	•	•	•	•	•
80B5	130	165	200	19	**	**	**	**	**	**	**	**	•	•	•	•	

2.9.6 SW HYBRID Motor flange availability

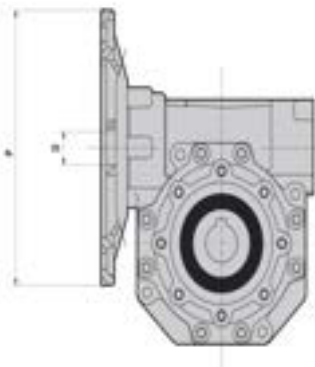

(\*) Low profile key supplied by Motovario.

The table report possible configurations strictly based on geometric criteria. To determine the compatibility of a motor-gear unit assembly in terms of mechanical factors, double check the selected configuration against the rating charts for SW/ISW performances.

SW	P	i											
		5	7,5	10	15	20	25	30	40	50	60	80	100
D													
030	140												
	120	11	11	11	11	11	11	11	11	11	9	9	-
	90	9	9	9	9	9	9	9	9	9			
	80												
040	160												
	140	14	14	14	14	14	14	14	14	11	11	11	11
	120	11	11	11	11	11	11	11	11	9	9	9	9
	105												
050	90												
	200												
	160	19	19	19	19	19	19	19	14	14	14	14	11
	140	14	14	14	14	14	14	14	11	11	11	11	
063	120												
	105												
	200												
	160	-	24	24	24	24	24	24	19	19	19	14	14
075	140												
	120												
	105												
	250	-	28	28	28	24	24	24	24	19	19	19	19
090	200												
	160	-	28	28	28	28	28	28	24	24	24	19	19
	140		24	24	24	24	24	24	19	19	19		
	120												
105	300	-	38*	38*	38*	38*	-	-	-	-	-	-	-
	250	-	28	28	28	28	28	28	28	28	28	24	24
	200						24	24	24	24	24	19	19

2.9.7 HA31+SW Motor flange availability

HA31 I1	SW 040 I2	I1xI2	63	71	80
2,94	7,5	22,08	B5	B5	B5
4,75	5	23,75	B5	B5	B5
5,10	5	25,50	B5	B5	
2,94	10	29,44	B5	B5	
6,30	5	31,50	B5	B5	
4,75	7,5	35,63	B5	B5	
5,45	7,5	40,91	B5	B5	
2,94	15	44,17	B5	B5	
4,75	10	47,50	B5	B5	
5,45	10	54,55	B5	B5	
2,94	20	58,89	B5	B5	
6,30	10	63,00	B5	B5	
4,75	15	71,25	B5	B5	
7,88	10	78,75	B5		
2,94	30	88,33	B5		
6,30	15	94,50	B5		
5,10	20	102,00	B5		
5,45	20	109,09	B5		
7,88	15	118,13	B5		
5,10	25	127,50	B5		
4,75	30	142,50	B5		
3,87	40	154,67	B5		
5,45	30	163,64	B5		
6,30	30	189,00	B5		
5,10	40	204,00	B5		

HA31 I1	SW 050 I2	I1xI2	63	71	80
2,94	7,5	22,08		B5	B5
4,75	5	23,75	B5	B5	B5
5,10	5	25,50	B5	B5	
2,94	10	29,44	B5	B5	B5
6,30	5	31,50	B5	B5	
4,75	7,5	35,63	B5	B5	B5
5,45	7,5	40,91	B5	B5	
2,94	15	44,17	B5	B5	B5
4,75	10	47,50	B5	B5	B5
5,45	10	54,55	B5	B5	
2,94	20	58,89	B5	B5	
6,30	10	63,00	B5	B5	
4,75	15	71,25	B5	B5	
7,88	10	78,75	B5	B5	
2,94	30	88,33	B5	B5	
6,30	15	94,50	B5	B5	
5,10	20	102,00	B5	B5	
5,45	20	109,09	B5	B5	
7,88	15	118,13	B5	B5	
5,10	25	127,50	B5	B5	
4,75	30	142,50	B5	B5	
3,87	40	154,67	B5	B5	
5,45	30	163,64	B5	B5	
6,30	30	189,00	B5		
5,10	40	204,00	B5		
7,88	30	236,25	B5		
6,30	40	252,00	B5		
5,45	50	272,73	B5		
4,75	60	285,00	B5		
6,30	50	315,00	B5		

HA31 I1	SW 063 I2	I1xI2	63	71	80
3,18	7,5	23,82	B5	B5	B5
2,94	10	29,44	B5	B5	B5
3,87	10	38,67	B5	B5	B5
2,94	15	44,17	B5	B5	B5
4,75	10	47,50	B5	B5	B5
2,94	20	58,89	B5	B5	B5
4,75	15	71,25	B5	B5	B5
3,87	20	77,33	B5	B5	B5
5,45	15	81,82	B5	B5	
2,94	30	88,33	B5	B5	B5
4,75	20	95,00	B5	B5	B5
5,10	20	102,00	B5	B5	
5,45	20	109,09	B5	B5	
3,87	30	116,00	B5	B5	B5
5,10	25	127,50	B5	B5	
4,75	30	142,50	B5	B5	B5
7,88	20	157,50	B5	B5	
4,21	40	168,57	B5	B5	B5
6,30	30	189,00	B5	B5	
5,10	40	204,00	B5	B5	
5,45	40	218,18	B5	B5	
7,88	30	236,25	B5	B5	
5,45	50	272,73	B5	B5	
7,88	40	315,00	B5	B5	
7,88	50	393,75	B5		
10,83	40	433,33	B5		
7,88	60	472,50	B5		
10,83	50	541,67	B5		
10,83	60	650,00	B5		

HA31 I1	SW 075 I2	I1xI2	63	71	80
3,87	20	77,33	B5	B5	B5
3,36	25	83,93	B5	B5	B5
3,18	30	95,29	B5	B5	B5
5,45	20	109,09	B5	B5	
2,94	40	117,78	B5	B5	B5
3,36	40	134,29	B5	B5	B5
4,75	30	142,50	B5	B5	B5
3,87	40	154,67	B5	B5	B5
5,45	30	163,64	B5	B5	
2,94	60	176,67	B5	B5	B5
3,87	50	193,33	B5	B5	B5
5,45	40	218,18	B5	B5	
4,75	50	237,50	B5	B5	B5
5,45	50	272,73	B5	B5	
7,88	40	315,00	B5	B5	
7,88	50	393,75	B5	B5	
7,88	60	472,50	B5	B5	
10,83	50	541,67	B5		
10,83	60	650,00	B5		
7,88	100	787,50	B5		
10,83	80	866,67	B5		

HA31 I1	SW 090 I2	I1xI2	63	71	80
2,55	40	102,00		B5	B5
2,94	40	117,78	B5	B5	B5
2,55	50	127,50		B5	B5
3,36	40	134,29	B5	B5	B5
2,94	50	147,22	B5	B5	B5
3,18	50	158,82	B5	B5	B5
3,36	50	167,86	B5	B5	B5
3,87	50	193,33	B5	B5	B5
3,36	60	201,43	B5	B5	B6
5,45	40	218,18	B5	B5	
4,75	50	237,50	B5	B5	B5
5,10	50	255,00	B5	B5	
5,45	50	272,73	B5	B5	
5,10	60	306,00	B5	B5	
5,45	60	327,27	B5	B5	
4,75	80	380,00	B5	B5	
5,10	80	408,00	B5	B5	
5,45	80	436,36	B5	B5	
7,88	60	472,50	B5	B5	
5,10	100	510,00	B5	B5	
5,45	100	545,45	B5	B5	
7,88	80	630,00	B5	B5	
10,83	60	650,00	B5		
7,88	100	787,50	B5	B5	
10,83	80	866,67	B5		



2.9.8 SW-CD Motor flange availability

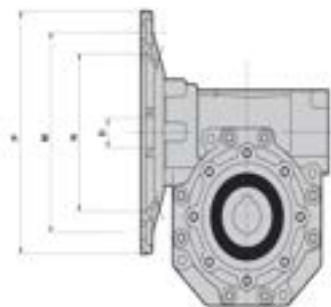

For B5 flanges call MOTOVARIO TECHNICAL SERVICE.

(•) Motor-ratio combination feasible.

(\*\*) Motor-ratio combination not feasible.

(+) Motor-ratio combination not to be used, out of warranty terms.

The table report possible configurations strictly based on geometric criteria. To determine the compatibility of a motor-gear unit assembly in terms of mechanical factors, double check the selected configuration against the rating charts for SW/ISW performances.

SW-CD	PAM IEC	N	M	P	D	i											
						5	7,5	10	15	20	25	30	40	50	60	80	100
030	63B14	60	75	90	11	•	•	•	•	•	•	•	•	•	**	**	**
	56B14	50	65	80	9	•	•	•	•	•	•	•	•	•	•	•	**
040	71B14	70	85	105	14	•	•	•	•	•	•	•	•	**	**	**	**
	63B14	60	75	90	11	•	•	•	•	•	•	•	•	•	•	•	•
050	80B14	80	100	120	19	•	•	•	•	•	•	•	•	**	**	**	**
	71B14	70	85	105	14	•	•	•	•	•	•	•	•	•	•	•	**
063	90B14	95	115	140	24	**	•	•	•	•	•	•	•	+	+	+	+
	80B14	80	100	120	19	**	•	•	•	•	•	•	**	**	**	**	**
	71B14	70	85	105	14	**	**	**	**	**	**	**	•	•	•	•	•
075	100/112B14	110	130	160	28	**	•	•	•	**	**	**	**	**	**	**	**
	90B14	95	115	140	24	**	•	•	•	•	•	•	•	**	**	**	**
	80B14	80	100	120	19	**	**	**	**	•	•	•	•	•	•	•	•
090	100/112B14	110	130	160	28	**	•	•	•	•	•	•	**	**	**	**	**
	90B14	95	115	140	24	**	•	•	•	•	•	•	•	•	•	**	**
	80B14	80	100	120	19	**	**	**	**	**	**	**	•	•	•	•	•

2.9.9 Ratios NRV/NMRV/NMRV-P+NMRV/NMRV-P

The table report possible configurations strictly based on geometric criteria. To determine the compatibility of a motor-gear unit assembly in terms of mechanical factors, double check the selected configuration against the rating charts performances.

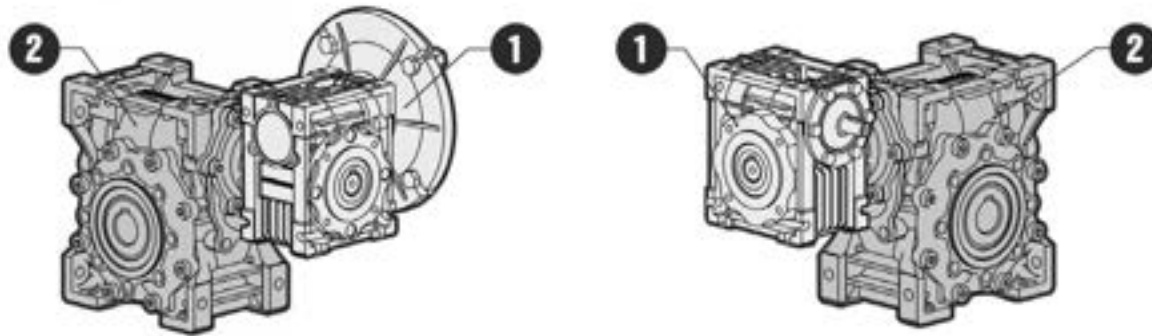

i	NMRV/NMRV	i1	i2
100	025/030	10	10
150		7.5	20
200		10	20
250		10	25
300		10	30
400		20	20
500		20	25
600		20	30
750		30	25
900		15	60
1200		30	40
1500		30	50
1800		60	30
2400		60	40
3000		60	50
4000		50	80

i	NMRV/NMRV	i1	i2
100	025/040	10	10
150		7.5	20
200		10	20
250		10	25
300		10	30
400		20	20
500		20	25
600		20	30
750		30	25
900		30	30
1200		30	40
1500		30	50
1800		60	30
2400		60	40
3000		60	50
4000		50	80
5000	50	100	

i	NMRV/NMRV NRV/NMRV	i1	i2
100	030/040	10	10
150		10	15
200		10	20
250		10	25
300		10	30
400		10	40
500		20	25
600		20	30
750		25	30
900		30	30
1200		40	30
1500		50	30
1800		60	30
2400		60	40
3000		60	50
4000		50	80
5000	50	100	

i	NMRV/NMRV NRV/NMRV	i1	i2
100	030/050	10	10
150		10	15
200		10	20
250		10	25
300		10	30
400		10	40
500		10	50
600		20	30
750		25	30
900		30	30
1200		40	30
1500		50	30
1800		60	30
2400		60	40
3000		60	50
4000		50	80
5000	50	100	

i	NMRV/NMRV-P NRV/NMRV-P	i1	i2
100	030/063	10	10
150		10	15
200		10	20
250		10	25
300		7.5	40
400		10	40
500		10	50
600		20	30
750		25	30
900		30	30
1200		40	30
1500		50	30
1800		60	30
2400		60	40
3000		60	50
4000		80	50
5000	50	100	

i	NMRV/NMRV NRV/NMRV	i1	i2
100	040/050	10	10
150		10	15
200		10	20
250		10	25
300		10	30
400		10	40
500		50	10
600		20	30
750		25	30
900		60	15
1200		40	30
1500		50	30
1800		60	30
2400		60	40
3000		60	50
4000		80	50
5000	100	50	

2.9 MOTOR FLANGE AVAILABILITY

i	NMRV/NMRV-P NRV/NMRV-P	i1	i2
100	040/063	10	10
150		10	15
200		10	20
250		10	25
300		10	30
400		10	40
500		20	25
600		20	30
750		25	30
900		30	30
1200		40	30
1500		50	30
1800		60	30
2400		60	40
3000		60	50
4000		80	50
5000	100	50	

i	NMRV/NMRV-P NRV/NMRV-P	i1	i2
100	040/075	10	10
150		10	15
200		10	20
250		10	25
300		10	30
400		10	40
500		10	50
600		20	30
750		25	30
900		30	30
1200		40	30
1500		50	30
1800		60	30
2400		60	40
3000		60	50
4000		80	50
5000	100	50	

i	NMRV/NMRV-P NRV/NMRV-P	i1	i2
100	040/090	10	10
150		10	15
200		10	20
250		10	25
300		10	30
400		10	40
500		10	50
600		20	30
750		25	30
900		30	30
1200		40	30
1500		50	30
1800		60	30
2400		60	40
3000		60	50
4000		80	50
5000	100	50	

i	NMRV/NMRV-P NRV/NMRV-P	i1	i2
100	050/090	10	10
150		10	15
200		10	20
250		10	25
300		10	30
400		10	40
500		20	25
600		20	30
750		25	30
900		30	30
1200		40	30
1500		50	30
1800		60	30
2400		60	40
3000		60	50
4000		80	50
5000	100	50	

i	NMRV/NMRV-P NRV/NMRV-P	i1	i2
100	050/110	10	10
150		10	15
200		10	20
250		10	25
300		10	30
400		10	40
500		20	25
600		20	30
750		25	30
900		30	30
1200		40	30
1500		50	30
1800		60	30
2400		60	40
3000		60	50
4000		80	50
5000	100	50	

i	NMRV-P/NMRV-P NRV-P/NMRV-P	i1	i2
100	063/110	10	10
150		10	15
200		10	20
250		10	25
300		10	30
400		10	40
500		20	25
600		20	30
750		25	30
900		30	30
1200		40	30
1500		50	30
1800		60	30
2400		60	40
3000		60	50
4000		80	50
5000	100	50	

i	NMRV-P/NMRV NRV-P/NMRV	i1	i2
100	063/130	10	10
150		10	15
200		10	20
250		10	25
300		10	30
400		10	40
500		10	50
600		20	30
750		25	30
900		30	30
1200		40	30
1500		50	30
1800		60	30
2400		60	40
3000		60	50
4000		80	50
5000	100	50	

i	NMRV-P/NMRV NRV-P/NMRV	i1	i2
150	063/150	7.5	20
200		10	20
250		10	25
300		15	20
400		10	40
500		10	50
600		15	40
750		15	50
900		30	30
1200		30	40
1500		30	50
1800		60	30
2400		60	40
3000		60	50
4000		80	50
5000		100	50

2.9.10 Ratios ISW/SW+SW

The table report possible configurations strictly based on geometric criteria. To determine the compatibility of a motor-gear unit assembly in terms of mechanical factors, double check the selected configuration against the rating charts performances.

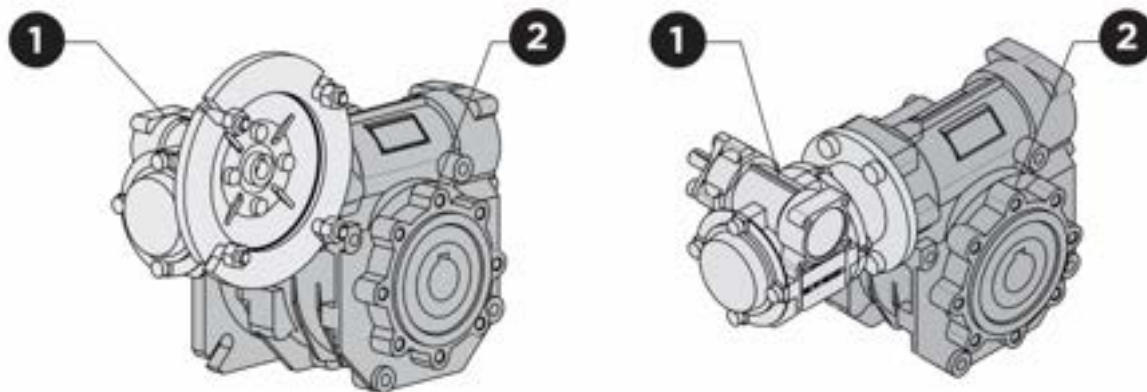

i	SW/SW ISW/SW	i1	i2
100	SW030/040	10	10
150		10	15
200		10	20
250		10	25
300		10	30
400		10	40
500		20	25
600		20	30
750		25	30
900		30	30
1200		40	30
1500		50	30
1800		60	30
2400		60	40
3000		60	50
4000		50	80
5000		50	100

i	SW/SW ISW/SW	i1	i2
100	SW030/050	10	10
150		10	15
200		10	20
250		10	25
300		10	30
400		10	40
500		10	50
600		20	30
750		25	30
900		30	30
1200		40	30
1500		50	30
1800		60	30
2400		60	40
3000		60	50
4000		50	80
5000		50	100

i	SW/SW ISW/SW	i1	i2
100	SW030/063	10	10
150		10	15
200		10	20
250		10	25
300		7,5	40
400		10	40
500		10	50
600		20	30
750		25	30
900		30	30
1200		40	30
1500		50	30
1800		60	30
2400		60	40
3000		60	50
4000		80	50
5000		50	100

2.9 MOTOR FLANGE AVAILABILITY

i	SW/SW ISW/SW	i1	i2
100	SW040/075	10	10
150		10	15
200		10	20
250		10	25
300		10	30
400		10	40
500		10	50
600		20	30
750		25	30
900		30	30
1200		40	30
1500		50	30
1800		60	30
2400		60	40
3000		60	50
4000		80	50
5000	100	50	

i	SW/SW ISW/SW	i1	i2
100	SW040/090	10	10
150		10	15
200		10	20
250		10	25
300		10	30
400		10	40
500		10	50
600		20	30
750		25	30
900		30	30
1200		40	30
1500		50	30
1800		60	30
2400		60	40
3000		60	50
4000		80	50
5000	100	50	

i	SW/SW ISW/SW	i1	i2
100	SW050/090	10	10
150		10	15
200		10	20
250		10	25
300		10	30
400		10	40
500		20	25
600		20	30
750		25	30
900		30	30
1200		40	30
1500		50	30
1800		60	30
2400		60	40
3000		60	50
4000		80	50
5000	100	50	

i	SW/SW ISW/SW	i1	i2
100	SW050/105	10	10
150		10	15
200		10	20
250		10	25
300		10	30
400		10	40
500		20	25
600		20	30
750		25	30
900		30	30
1200		40	30
1500		50	30
1800		60	30
2400		60	40
3000		60	50
4000		80	50
5000	100	50	

VSF		Standard	On request
NMRV	025	1	/
NMRV - SW	030	1	/
NMRV - SW	040	1	2
NMRV - SW	050	1	2
NMRV-P - SW	063	1	2
NMRV-P - SW	075	1	2
NMRV-P - SW	090	1	2
SW	105	1	2
NMRV-P - SW	110	1	2
NMRV	130	1	2
NMRV	150	1	2

1 - Ball Bearing

2 - Roller bearings

/ - Not available

### 2.11.1 Information

The value of the admissible radial load [N] is given in the tables relating to the performance of the gear reducer at issue. It is related to the load applied on the centre line of the shaft and in the most unfavourable conditions of angle of application and direction of rotation. The maximum admissible axial loads are 1/5 of the value of the given radial load when they are applied in combination with the radial load. The tables relating to the output shafts give the maximum admissible value. This value must never be exceeded since it relates to the strength of the case. Particular conditions of radial load higher than the limits of the catalogue may occur. In this case, call our Technical Service and provide details on the application: direction of the load, direction of rotation of the shaft, type of service. In case of double extension shafts with radial load applied on both ends, the max. admissible radial loads must be defined according to the specific running conditions, in this case call our Technical Service. The radial load on the shaft is calculated with the following formula:

$$Fr_e = (2000 \cdot M \cdot fz) / D \leq Fr1 \text{ or } Fr2$$

- **Fre** [N] Resulting radial load
- **M** [Nm] Torque on the shaft
- **D** [mm] Diameter of the transmission member mounted on the shaft
- **Fr1-Fr2** [N] Value of the maximum admitted radial load (see relative tables)
- **fz** = 1,1 gear pinion - 1,4 chain wheel - 1,7 v-pulley - 2,5 flat pulley

### 2.11.2 Input

When the radial load is not on the center line of the shaft, it is necessary to adjust the admissible radial load Fr1 with the following formula:  $Fr_x = (Fr1 \cdot a) / (b + x)$

- **a, b** = values given in the tables
- **x** = distance from the point of application of the load to the shaft shoulder

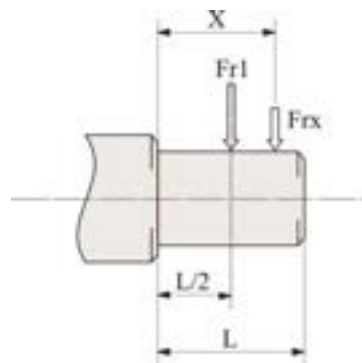

NRV/NRV-P	030	040	050	063	075	090	110	130	150
a	86	106	129	159	192	227	266	314	350
b	76	94,5	114	139	167	202	236	274	310
Fr1 max(**)	210	350	490	700	980	1270	1700	2100	2800

ISW	030	040	050	063	075	090	105
a	86	106	129	159	192	227	266
b	76	94,5	114	139	167	202	236
Fr1 max(**)	210	350	490	700	980	1270	1700

IHW040	090	110
a	71	71
b	51	51
Fr1 max(**)	400	500

(\*\*Fr1 max) Max admissible value of the reducer in static conditions and/or for limited operations. For continuous overhung loads please check the values on the performances tables calculated according to the casing, the shaft and bearings.

### 2.11.3 Output

When the radial load is not on the centre line of the shaft, it is necessary to adjust the admissible radial load  $Fr_2$  with the following formula:  $Fr_x = (Fr_2 \cdot a) / (b + x)$

- $a, b$  = values given in the tables
- $x$  = distance from the point of application of the load to the shaft shoulder

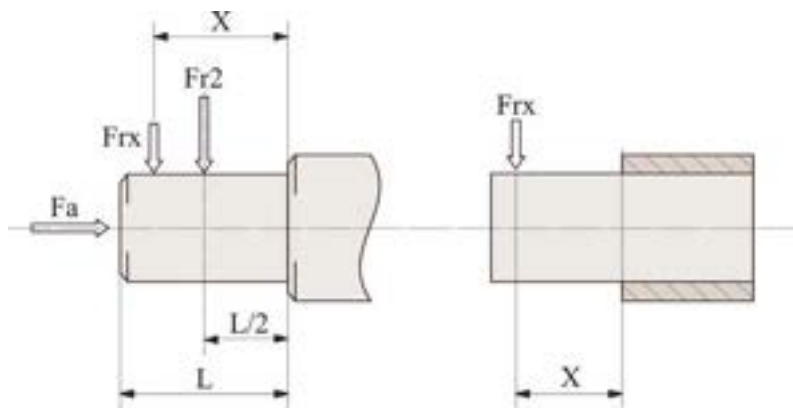

NMRV NMRV-P	025	030	040	050	063	075	090	110	130	150
a	50	65	84	101	120	131	162	176	188	215
b	38	50	64	76	95	101	122	136	148	174
Fr2 max(**)	1350	1830	3490	4840	6270	7380	8180	12000	13500	18000

SW	030	040	050	063	075	090	105
a	65	84	101	120	131	162	176
b	50	64	76	95	101	122	136
Fr2 max(**)	1830	3490	4840	6270	7380	8180	10320

(\*\*Fr2 max) Max admissible value of the reducer in static conditions and/or for limited operations. For continuous overhung loads please check the values on the performances tables calculated according to the casing, the shaft and bearings.



### 2.12.1 Information

In cases of ambient temperatures not envisaged in the table, call our Technical Service. In the case of temperatures under -30°C or over 60°C it is necessary to use oil seals with special properties. For operating ranges with temperatures under 0°C it is necessary to consider the following:

1. The motors need to be suitable for operation at the envisaged ambient temperature.
2. The power of the electric motor needs to be adequate for exceeding the higher starting torques required.
3. In case of cast-iron gear reducers, pay attention to impact loads since cast iron may have problems of fragility at temperatures under -15°C.
4. During the early stages of service, problems of lubrication may arise due to the high level of viscosity taken on by the oil and so it is wise to have a few minutes of rotation under no load.

Oil (NON Atex products) must be changed after approx. 10000 hours/2 years of operation; this time varies based on the type of service and on the environment inside which the gear reducer is installed. Units not featuring any oil plug are life-lubricated, and therefore maintenance-free.

### 2.12.2 Lubricants

Specifications of lubricants recommended by Motovario.

All units are supplied with LAND OIL oil, unless otherwise specified by the client.

	HA31	NMRV 025 ÷ 150 NMRV-P 063 ÷ 110 SW 030 ÷ 105 HW 030 ÷ 040 SW-CD/A 030 ÷ 090 SW-CD/C 030 ÷ 090	SW-CD/D 030 ÷ 090
	Mineral oil	Synthetic oil	Synthetic oil
T <sub>amb</sub> °C ISO	(-5) ÷ (+40) ISO VG220	(-25) ÷ (+50) ISO VG320	(-15) ÷ (+40) ISO VG320
LAND OIL	GEAR POWER 220	GEAR SINT 320	-
ENI	BLASIA 220	TELUM VSF320	-
SHELL	OMALA OIL220	OMALA S4 WE320	-
KLUBER	Kluberoil GEM 1-220N	Klubersynth GH 6-320	Klubersynth UH1 6-320
MOBIL	MOBILGEAR 600 XP220	-	-
CASTROL	ALPHA SP 220	ALPHASYN PG320	-
BP	ENERGOL GR-XP220	ENERGOL SG-XP320	-
PETRONAS	GEAR MEP 220	GEAR SYN PAG 320	-

## 2.12.3 Special lubricants

	$T_{amb}^{\circ C}$	Polyglycol synthetic oil
ENI	(-30) ÷ (+30)	Blasia S 150 (ISO VG150)
	(-20) ÷ (+40)	Blasia S 220 (ISO VG220)
KLUBER	(-40) ÷ (+5)	Klubersynth GH 6-32 (ISO VG32)
	(-35) ÷ 10)	Klubersynth GH 6-80 (ISO VG80)
	(-30) ÷ (+40)	Klubersynth GH 6-150 (ISO VG150)
	(-25) ÷ (+40)	Klubersynth GH 6-220 (ISO VG220)
	(-15) ÷ (+50)	Klubersynth GH 6-460 (ISO VG460)
	(-10) ÷ (+70)	Klubersynth GH 6-680 (ISO VG680)
	$T_{amb}^{\circ C}$	Polyglycol synthetic oil for food grade
KLUBER	(-30) ÷ (+15)	Klubersynth UH1-6 100 (ISO VG100)
	(-25) ÷ (+40)	Klubersynth UH1-6 220 (ISO VG220)
	(-15) ÷ (+40)	Klubersynth UH1-6 320 (ISO VG320)
	(-15) ÷ (+50)	Klubersynth UH1-6 460 (ISO VG460)
	(-10) ÷ (+50)	Klubersynth UH1-6 680 (ISO VG680)

If 'special' lubricant is required please contact MOTOVARIO TECHNICAL SERVICE.

### 2.12.4 Quantity

- The gear reducers size 025 - 030 - 040 - 050 - 063 - 075 - 090 - 105 - 110 - 130 - 150 are supplied complete with lubricant for life, synthetic oil, LAND OIL GEAR SINT. They can be mounted in any position envisaged in the catalogue, except for NMRV-P/SW 090 - 110 and NRV-P/ISW 075-090-110 for which you must to specify the mounting position.
- For sizes 130 and 150 it is necessary to specify the position, otherwise the gear reducers are supplied with the quantity of oil relating to pos. B3.
- Only reduction units 130 and 150 are fitted with breather, level and oil drainage plugs.
- The pre-stage helical modules are supplied complete with life-long lubricant, synthetic oil, LAND OIL GEAR SINT. Lubrication is separated from that of the worm gear reducers.

It is recommended, after installation, to replace the closed plug used for transportation with the supplied breather plug.

Quantity of oil in litres ~

NMRV	025	030	040	050	130	150
B3	0,02	0,04	0,08	0,15	4,5	7
B8					3,3	5,1
B6-B7					3,5	5,4
V5					4,5	7
V6					3,3	5,1

NMRV-P	063	075	090	110
B3	0,33	0,55	1,15	1,6
B8				
B6-B7				
V5				
V6				

SW	030	040	050	063	075	090	105
B3	0,04	0,08	0,15	0,3	0,55	1	1,6
B8							
B6-B7							
V5							
V6							

HW	HW030		HW040	
	NMRV-P063	NMRV-P075	NMRV-P090	NMRV-P110
B3-B6-B7-B8-V5-V6	0,06	0,09	0,11	0,12

H	A31
B3-B5	0,07

The following values of J1 moment of inertia are only estimated, referred to the maximum calculated, and to the gearbox input side.

NMRV-SW	J <sub>1</sub> [Kg*m <sup>2</sup> ]
025	0,000003
030	0,00001
040	0,00003
050	0,0001
063	0,0002
075	0,0003
090	0,0005
105	0,0014
130	0,0022
150	0,0053

HA-1	J <sub>1</sub> [Kg*m <sup>2</sup> ]
A31	0,0001

NMRV-P	J <sub>1</sub> [Kg*m <sup>2</sup> ]
063	0,0002
075	0,0004
090	0,0008
110	0,0020

3.1.1 NMRV 025

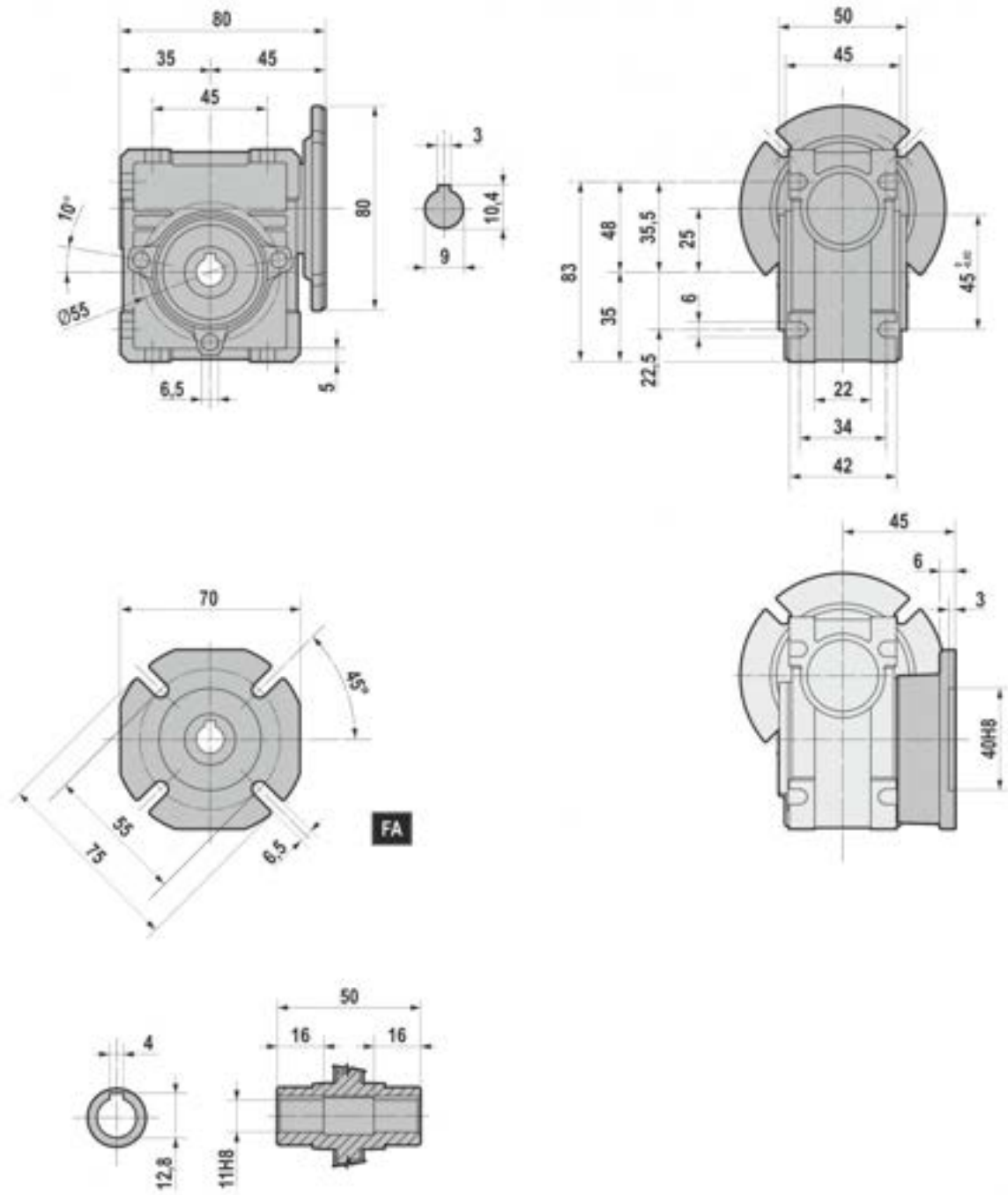

3.1.2 NMRV 030-150

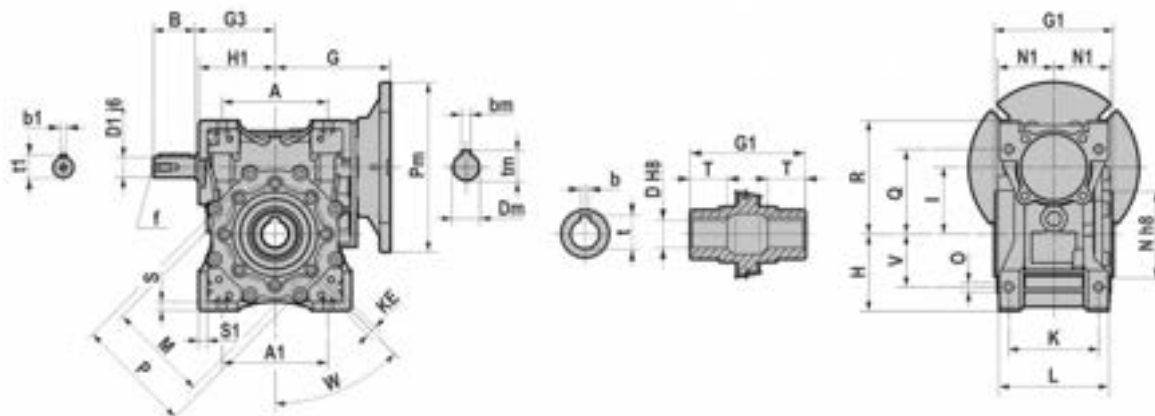

	030	040	050	063	075	090	110	130	150
A	54	70	80	100	120	140	170	200	240
A1	54	70	80	100	120	140	164 - 170	200	240
B	20	23	30	40	50	50	60	80	80
D1 j6	9	11	14	19	24	24	28	30	35
G	55	70	80	109	126,5	145	185,5 (PAM 132) 168 (PAM 080/112)	180	210
G1	63	78	92	112	120	140	155	170	200
G3	45	53	64	75	90	108	135	155	175
H	40	50	60	72	86	103	127,5	147,5	170
H1	40	50	60	72	89	103	127,5	147,5	170
I	30	40	50	63	75	90	110	130	150
K	44	60	70	85	90 - 95	100	115	120	145
KE	M6*11	M6*11	M8*10	M8*14	M8*14	M10*18	M10*18	M12*21	M12*21
L	56	71	85	103	112	130	144	155	185
M	65	75	85	95	115	130	165	215	215
N	55	60	70	80	95	110	130	180	180
N1	29	36,5	43,5	53	57	67	74	81	96
O	6,5	6,5	8,5	8,5	11	13	14	16	18
P	75	87	100	110	131	160	200	250	250
Q	44	55	64	80	93	102	125	140	180
R	57	71,5	84	107	123	144	167,5	187,5	230
S	5,5	6,5	7	8	10	11	14,5	15,5	18
S1	5,5	6,5	7	8	13	11	14,5	15,5	18
V	27	35	40	50	60	70	82 - 85	100	120
W	0	45	45	45	45	45	45	45	45
b1	3	4	5	6	8	8	8	8	10
t1	10,2	12,5	16	21,5	27	27	31	33	38
f1	-	-	M6	M6	M8	M8	M10	M10	M12

	D H8	b	t	T
030	14	5	16,3	21
040	18	6	20,8	26
	19	6	21,8	26
050	25	8	28,3	30
	24	8	27,3	30
063	25	8	28,3	36
	28	8	31,3	36
075	28	8	31,3	40
	30	8	33,3	40
	32	10	35,3	40
090	35	10	38,3	40
	35	10	38,3	45
	38	10	41,3	45
110	42	12	45,3	50
130	45	14	48,8	60
150	50	14	53,8	72,5

B5	Pm	Dm	bm	tm
063	140	11	4	12,8
071	160	14	5	16,3
080	200	19	6	21,8
090	200	24	8	27,3
100	250	28	8	31,3
112	250	28	8	31,3
132	300	38	10	41,3
160	350	42	12	45,3

B14	Pm	Dm	bm	tm
056	80	09	3	10,4
063	90	11	4	12,8
071	105	14	5	16,3
080	120	19	6	21,8
090	140	24	8	27,3
100	160	28	8	31,3
112	160	28	8	31,3

3.1.3 SW

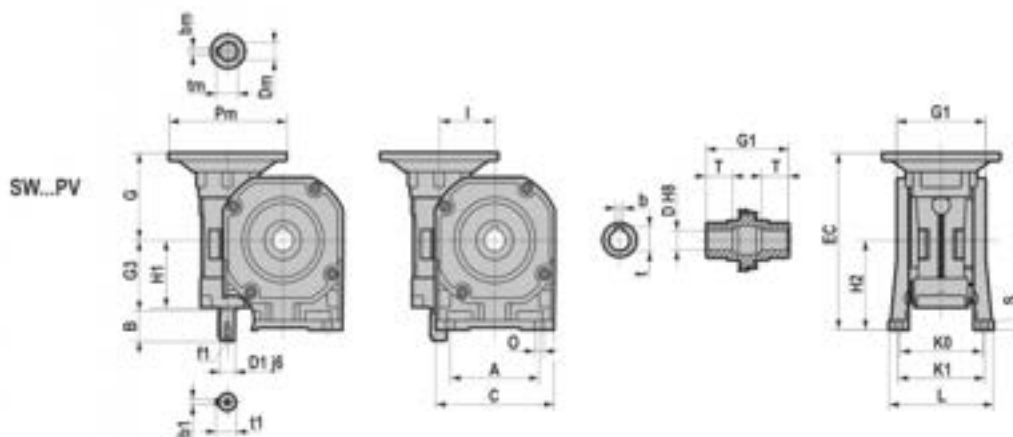
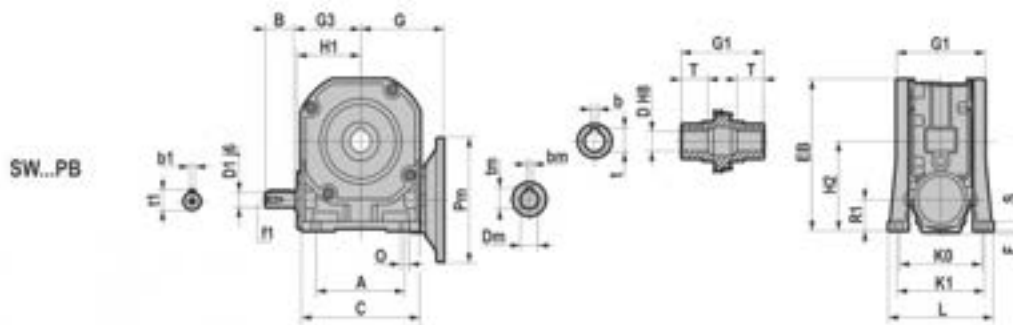
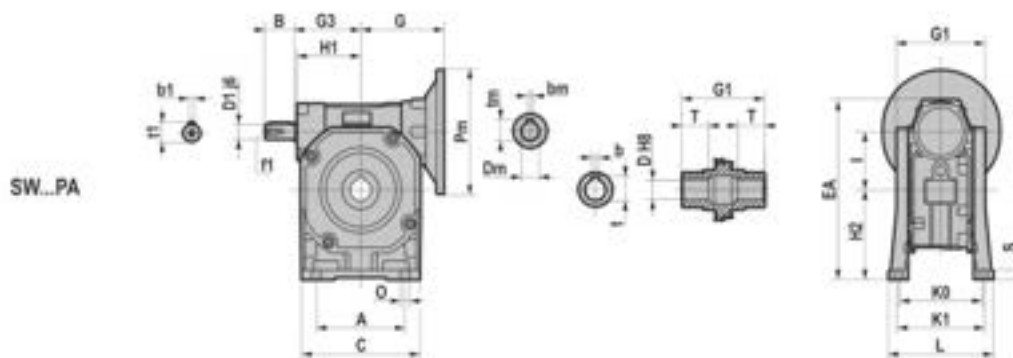
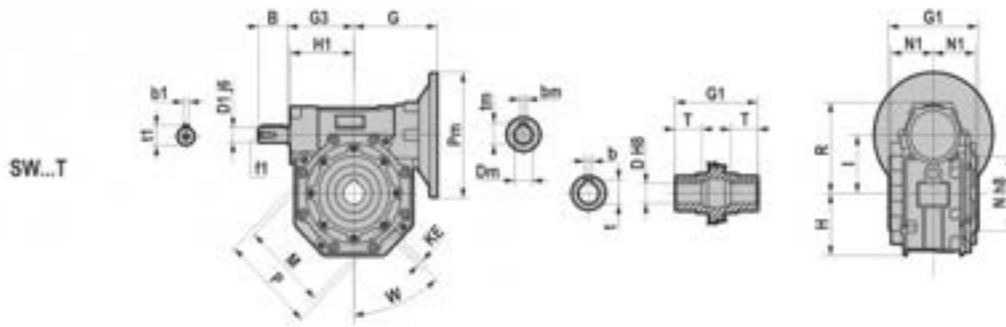

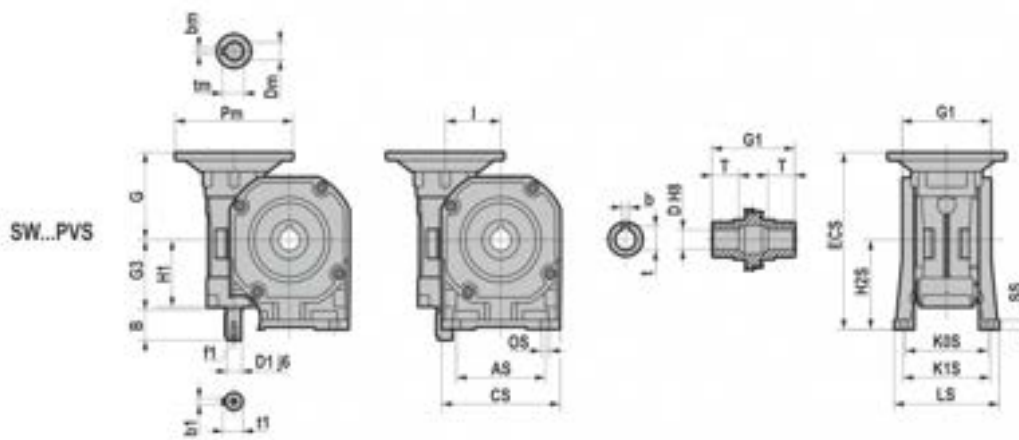
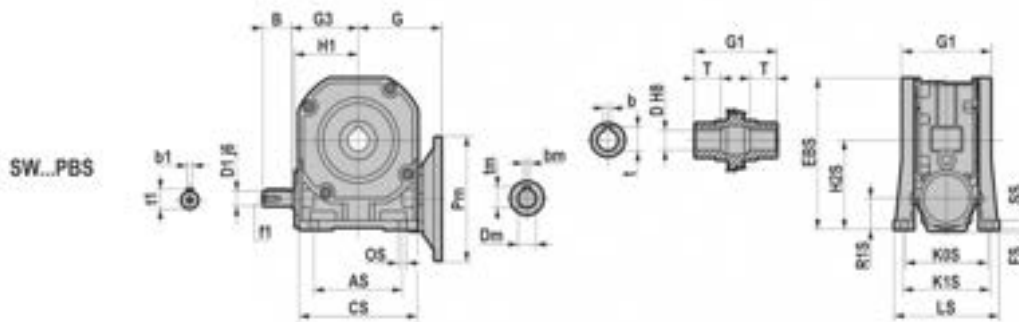
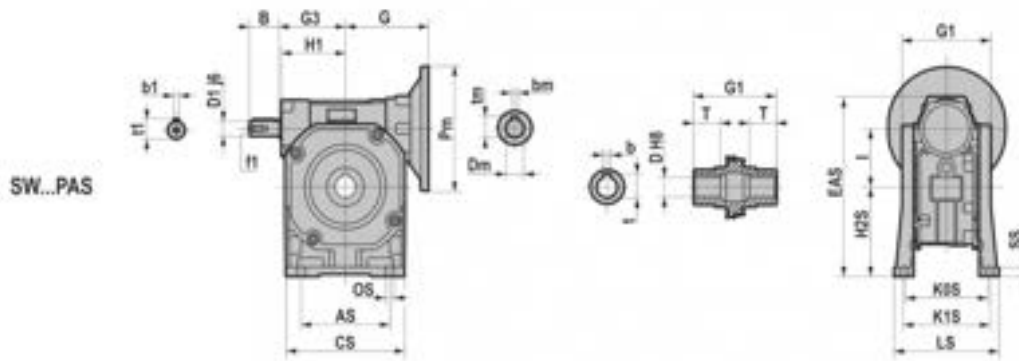



### 3.1 REDUCERS/GEARED MOTORS

	030	040	050	063	075	090	105
<b>G</b>	55	70	80	95	112,5	129,5	160
<b>G1</b>	63	78	92	112	120	140	155
<b>G3</b>	45	53	64	75	90	108	135
<b>H</b>	37,5	42	52	66	80	97	115
<b>H1</b>	40	50	60	72	86	103	127,5
<b>I</b>	30	40	50	63	75	90	110
<b>KE</b>	M6*11	M6*11	M8*10	M8*14	M8*14	M10*18	M10*18
<b>M</b>	65	75	85	95	115	130	165
<b>N</b>	55	60	70	80	95	110	130
<b>N1</b>	29	36,5	43,5	53	57	67	74
<b>P</b>	75	87	97,6	110	130	148	200
<b>R</b>	57	70	84	102	117	133	166
<b>W</b>	90	45	45	45	45	45	45
<b>B</b>	20	23	30	40	50	50	60
<b>D1</b>							
<b>j6</b>	9	11	14	19	24	24	28
<b>b1</b>	3	4	5	6	8	8	8
<b>t1</b>	10,2	12,5	16	21,5	27	27	27
<b>f1</b>	/	/	M6	M6	M8	M8	M10

	030	040	050	063	075	090	105
<b>A</b>	50	52	63	95	120	140	200
<b>C</b>	80	90	110	140	160	200	250
<b>EA</b>	112	142	166	202	232	275	338
<b>EB</b>	96,5	117	137	170	196	242	293,5
<b>EC</b>	110	142	162	195	227,5	271,5	332
<b>F</b>	2,00	/	2	2	2	/	/
<b>H2</b>	55	72	82	100	115	142	172
<b>KO</b>	66	81	98,5	111	115	140	160
<b>K1</b>	/	/	/	/	/	146	181
<b>L</b>	80	98	124	138	142	180	208
<b>O</b>	7	9	9	12	12	13	13
<b>R1</b>	30	32	32	37	40	52	62
<b>S</b>	7	9	10	10	12	14	18
<b>AS</b>	/	70	85	/	/	160	200
<b>CS</b>	/	96	112	/	/	210	250
<b>EAS</b>	/	141	169	/	/	283	336
<b>EBS</b>	/	116	141	/	/	250	291,5
<b>ECS</b>	/	141	165	/	/	279,5	330
<b>FS</b>	/	/	/	/	/	/	/
<b>H2S</b>	/	71	85	/	/	150	170
<b>KOS</b>	/	84	96	/	/	164	160
<b>K1S</b>	/	/	99	/	/	/	181
<b>LS</b>	/	100	116	/	/	195	208
<b>OS</b>	/	7	9	/	/	13	13
<b>R1S</b>	/	31	35	/	/	60	60
<b>SS</b>	/	9	10	/	/	14	16

	D H8	b	t	T
<b>030</b>	14	5	16,3	21
<b>040</b>	18	6	20,8	26
	19	6	21,8	26
<b>050</b>	25	8	28,3	30
	24	8	27,3	30
<b>063</b>	25	8	28,3	36
	28	8	31,3	36
<b>075</b>	28	8	31,3	40
	30	8	33,3	40
	32	10	35,3	40
	35	10	38,3	40
<b>090</b>	35	10	38,3	45
	38	10	41,3	45
<b>105</b>	40	12	43,3	45
	42	12	45,3	50

B5	Pm	Dm	bm	tm
<b>063</b>	140	11	4	12,8
<b>071</b>	160	14	5	16,3
<b>080</b>	200	19	6	21,8
<b>090</b>	200	24	8	27,3
<b>100</b>	250	28	8	31,3
<b>112</b>	250	28	8	31,3
<b>132</b>	300	38	10	41,3
<b>160</b>	350	42	12	45,3

B14	Pm	Dm	bm	tm
<b>056</b>	80	09	3	10,4
<b>063</b>	90	11	4	12,8
<b>071</b>	105	14	5	16,3
<b>080</b>	120	19	6	21,8
<b>090</b>	140	24	8	27,3
<b>100</b>	160	28	8	31,3
<b>112</b>	160	28	8	31,3

3.1.4 NRV

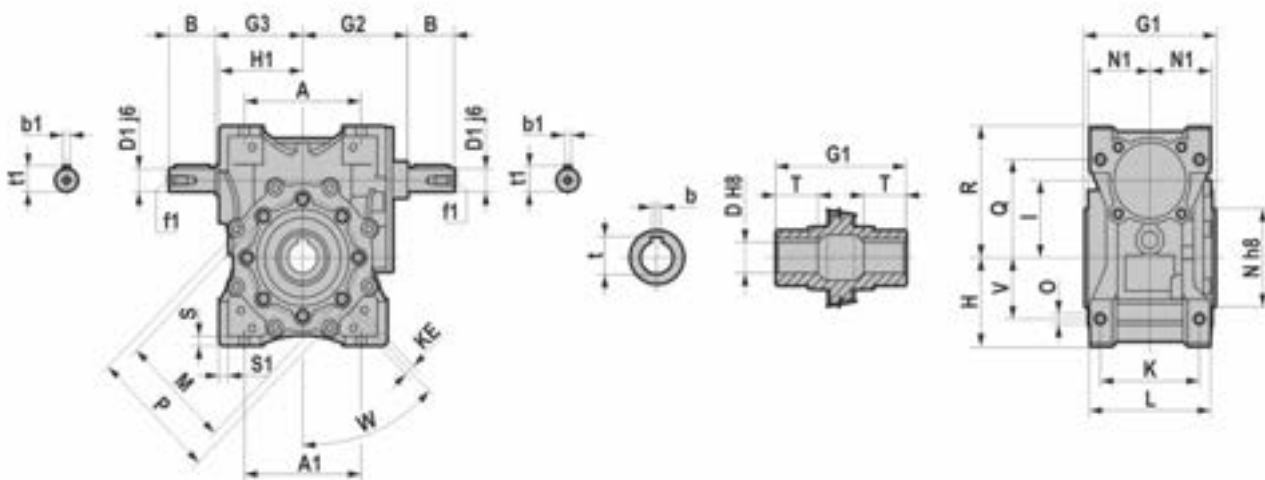

	030	040	050	063	075	090	110	130	150
<b>A</b>	54	70	80	100	120	140	170	200	240
<b>A1</b>	54	70	80	100	120	140	164 - 170	200	240
<b>B</b>	20	23	30	40	50	50	60	80	80
<b>D1 j6</b>	9	11	14	19	24	24	28	30	35
<b>G1</b>	63	78	92	112	120	140	155	170	200
<b>G2</b>	51	60	74	90	105	125	142	162	195
<b>G3</b>	45	53	64	75	90	108	135	155	175
<b>H</b>	40	50	60	72	86	103	127,5	147,5	170
<b>H1</b>	40	50	60	72	89	103	127,5	147,5	170
<b>I</b>	30	40	50	63	75	90	110	130	150
<b>K</b>	44	60	70	85	90 - 95	100	115	120	145
<b>KE</b>	M6*11	M6*11	M8*10	M8*14	M8*14	M10*18	M10*18	M12*21	M12*21
<b>L</b>	56	71	85	103	112	130	144	155	185
<b>M</b>	65	75	85	95	115	130	165	215	215
<b>N</b>	55	60	70	80	95	110	130	180	180
<b>N1</b>	29	36,5	43,5	53	57	67	74	81	96
<b>O</b>	6,5	6,5	8,5	8,5	11	13	14	16	18
<b>P</b>	75	87	100	110	131	160	200	250	250
<b>Q</b>	44	55	64	80	93	102	125	140	180
<b>R</b>	57	71,5	84	107	123	144	167,5	187,5	230
<b>S</b>	5,5	6,5	7	8	10	11	14,5	15,5	18
<b>S1</b>	5,5	6,5	7	8	13	11	14,5	15,5	18
<b>V</b>	27	35	40	50	60	70	82 - 85	100	120
<b>W</b>	0	45	45	45	45	45	45	45	45
<b>b1</b>	3	4	5	6	8	8	8	8	10
<b>t1</b>	10,2	12,5	16	21,5	27	27	31	33	38
<b>f1</b>	-	-	M6	M6	M8	M8	M10	M10	M12

	D H8	b	t	T
<b>030</b>	14	5	16,3	21
<b>040</b>	18	6	20,8	26
	19	6	21,8	26
<b>050</b>	25	8	28,3	30
	24	8	27,3	30
<b>063</b>	25	8	28,3	36
	28	8	31,3	36
<b>075</b>	28	8	31,3	40
	30	8	33,3	40
	32	10	35,3	40
	35	10	38,3	40
<b>090</b>	35	10	38,3	45
	38	10	41,3	45
	40	12	43,3	45
<b>110</b>	42	12	45,3	50
<b>130</b>	45	14	48,8	60
<b>150</b>	50	14	53,8	72,5

3.1.5 ISW

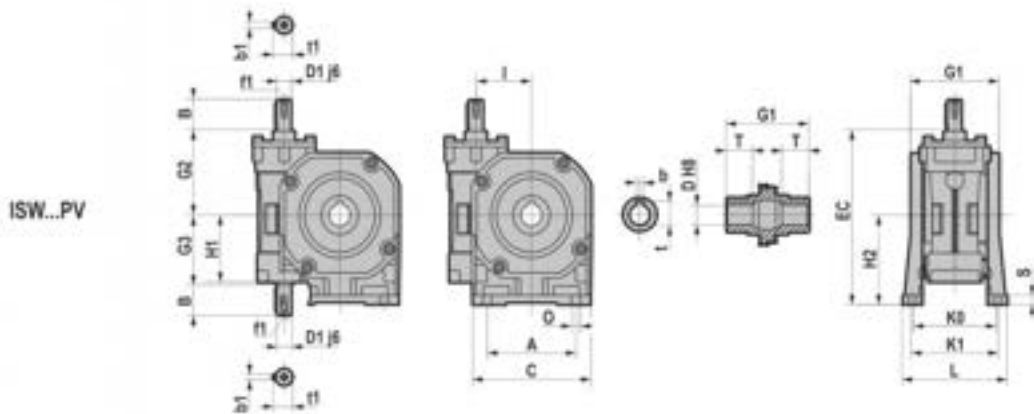
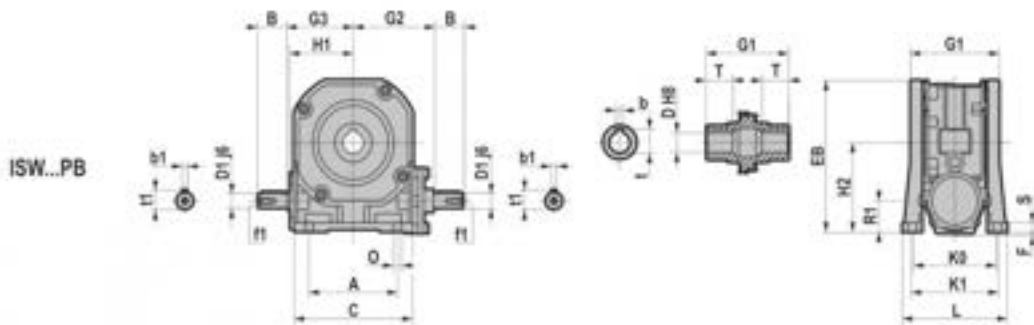
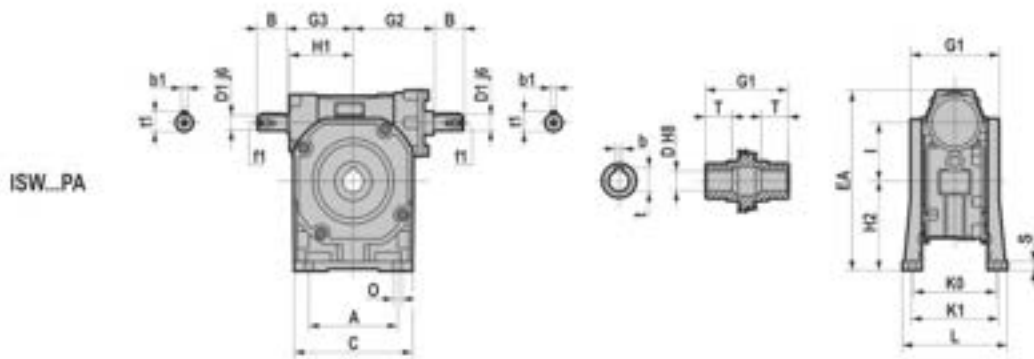
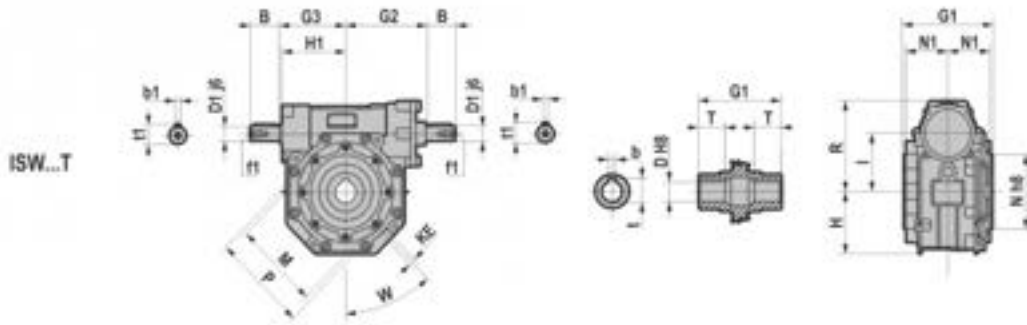

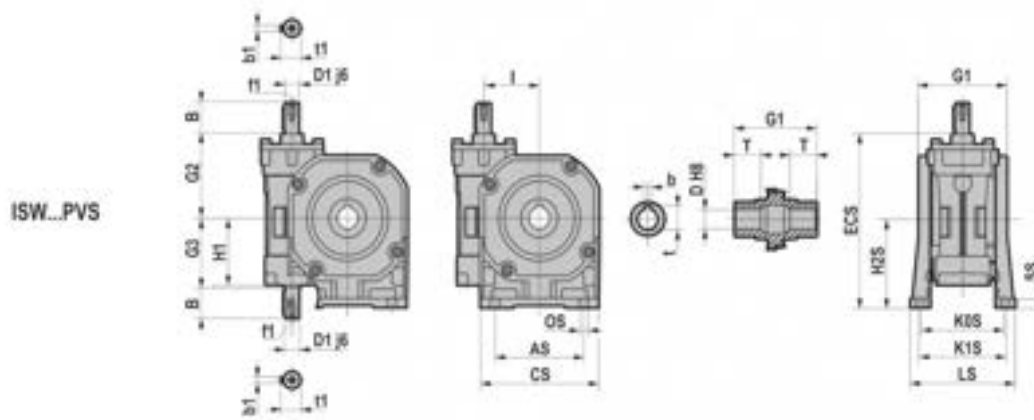
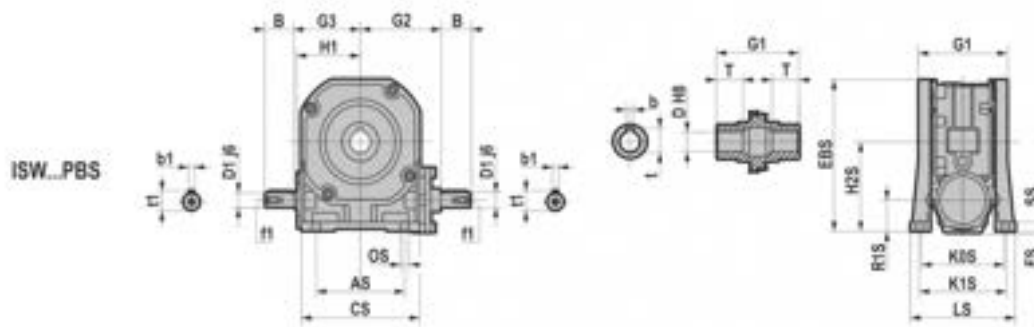
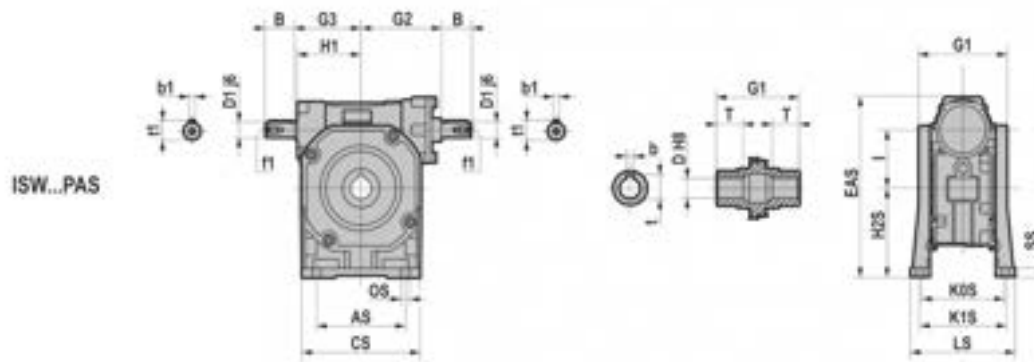

3.1 REDUCERS/GEARED MOTORS

		030	040	050	063	075	090	105
...T ...PA ...PB ...PV ...PAS ...PBS ...PVS	G1	63	78	92	112	120	140	155
	G2	51	60	74	90	105	125	142
	G3	45	53	64	75	90	108	135
	H	37,5	42	52	66	80	97	115
	H1	40	50	60	72	86	103	127,5
	I	30	40	50	63	75	90	110
	KE	M6*11	M6*11	M8*10	M8*14	M8*14	M10*18	M10*18
	M	65	75	85	95	115	130	165
	N	55	60	70	80	95	110	130
	N1	29	36,5	43,5	53	57	67	74
	P	75	87	97,6	110	130	148	200
	R	57	70	84	102	117	133	166
	W	90	45	45	45	45	45	45
	B	20	23	30	40	50	50	60
	D1 j6	9	11	14	19	24	24	28
	b1	3	4	5	6	8	8	8
	t1	10,2	12,5	16	21,5	27	27	27
f1	/	/	M6	M6	M8	M8	M10	

		030	040	050	063	075	090	105
...PA ...PB ...PV	A	50	52	63	95	120	140	200
	C	80	90	110	140	160	200	250
	EA	112	142	166	202	232	275	338
	EB	96,5	117	137	170	196	242	293,5
	EC	110	142	162	195	227,5	271,5	332
	F	2,00	/	2	2	2	/	/
	H2	55	72	82	100	115	142	172
	KO	66	81	98,5	111	115	140	160
	K1	/	/	/	/	/	146	181
	L	80	98	124	138	142	180	208
	O	7	9	9	12	12	13	13
	R1	30	32	32	37	40	52	62
	S	7	9	10	10	12	14	18
	AS	/	70	85	/	/	160	200
	CS	/	96	112	/	/	210	250
	EAS	/	141	169	/	/	283	336
	EBS	/	116	141	/	/	250	291,5
ECS	/	141	165	/	/	279,5	330	
...PAS ...PBS ...PVS	FS	/	/	/	/	/	/	/
	H2S	/	71	85	/	/	150	170
	KOS	/	84	96	/	/	164	160
	K1S	/	/	99	/	/	/	181
	LS	/	100	116	/	/	195	208
	OS	/	7	9	/	/	13	13
	RIS	/	31	35	/	/	60	60
	SS	/	9	10	/	/	14	16

	D H8	b	t	T
030	14	5	16,3	21
040	18	6	20,8	26
	19	6	21,8	26
050	25	8	28,3	30
	24	8	27,3	30
063	25	8	28,3	36
	28	8	31,3	36
075	28	8	31,3	40
	30	8	33,3	40
	32	10	35,3	40
	35	10	38,3	40
090	35	10	38,3	45
	38	10	41,3	45
105	40	12	43,3	45
	42	12	45,3	50

3.1.6 HA31+NMRV

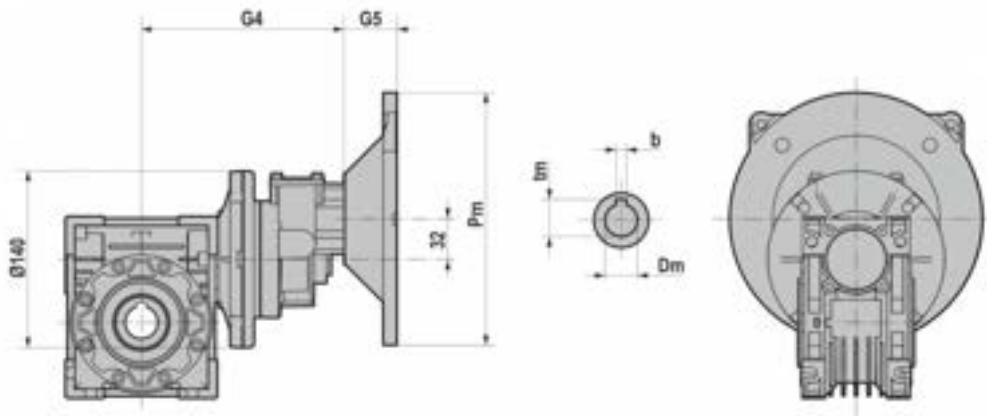

	NMRV040		NMRV050	
	G4	G5	G4	G5
<b>063</b>	150	25	160	25
<b>071</b>	150	32	160	32
<b>080</b>	150	42	160	42

B5	Pm	Dm	bm	tm
<b>063</b>	140	11	4	12,8
<b>071</b>	160	14	5	16,3
<b>080</b>	200	19	6	21,8

3.1.7 HA31+SW

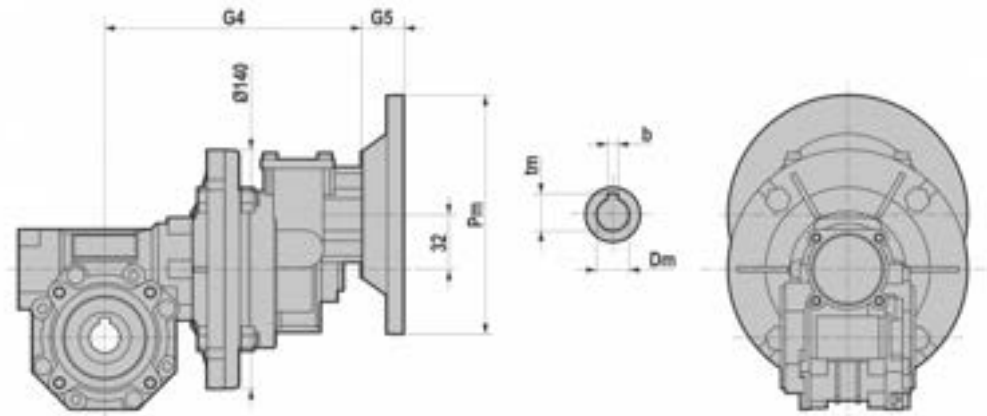

	SW040		SW050		SW063		SW075		SW090	
	G4	G5	G4	G5	G4	G5	G4	G5	G4	G5
<b>063</b>	150	25	160	25	173	25	187	25	204	25
<b>071</b>	150	32	160	32	173	32	187	32	204	32
<b>080</b>	150	42	160	42	173	42	187	42	204	42

B5	Pm	Dm	bm	tm
<b>063</b>	140	11	4	12,8
<b>071</b>	160	14	5	16,3
<b>080</b>	200	19	6	21,8

3.1.8 NMRV-P/HW

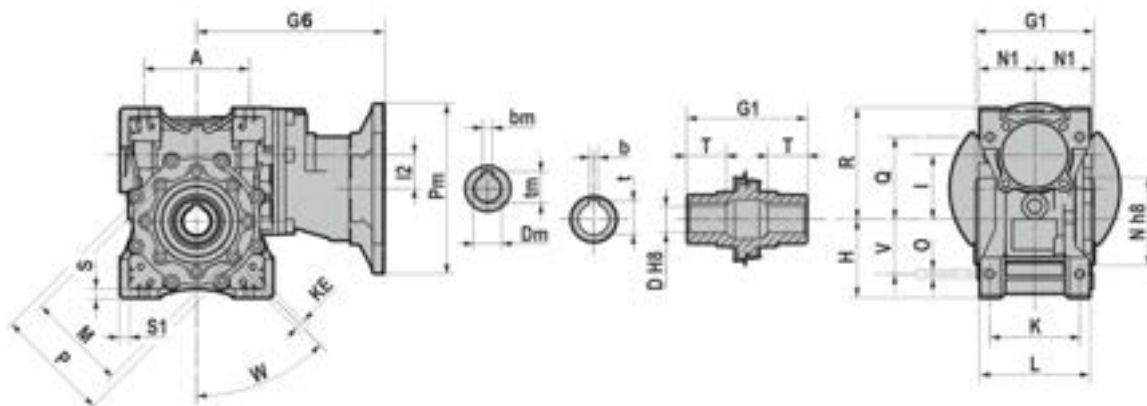

	HW030		HW040	
	056/063/071/080		063/071/080/090	
	NMRV-P 063	NMRV-P 075	NMRV-P 090	NMRV-P 110
A	100	120	140	170
G1	112	120	140	155
G6	176,5	194	218	241
H	72	86	103	127,5
H1	72	89	103	127,5
I	63	75	90	110
I2	32	32	42	42
K	85	90 - 95	100	115
KE	M8*14	M8*14	M10*18	M10*18
L	103	112	130	144
M	95	115	130	165
N	80	95	110	130
N1	53	57	67	74
O	8,5	11	13	14
P	110	131	160	200
Q	80	93	102	125
R	107	123	144	167,5
S	8	10	11	14,5
S1	8	13	11	14,5
V	50	60	70	82 - 85
W	45	45	45	45

NMRV-P	D H8	b	t	T
063	25	8	28,3	36
	28	8	31,3	36
075	28	8	31,3	40
	30	8	33,3	40
	32	10	35,3	40
090	35	10	38,3	40
	35	10	38,3	45
	38	10	41,3	45
110	40	12	43,3	45
	42	12	45,3	50

B5	Pm	Dm	bm	tm
056	120	09	3	10,4
063	140	11	4	12,8
071	160	14	5	16,3
080	200	19	6	21,8
090	200	24	8	27,3

B14	Pm	Dm	bm	tm
056	80	09	3	10,4
063	90	11	4	12,8
071	105	14	5	16,3
080	120	19	6	21,8
090	140	24	8	27,3

3.1.9 NMRV-P/IHW

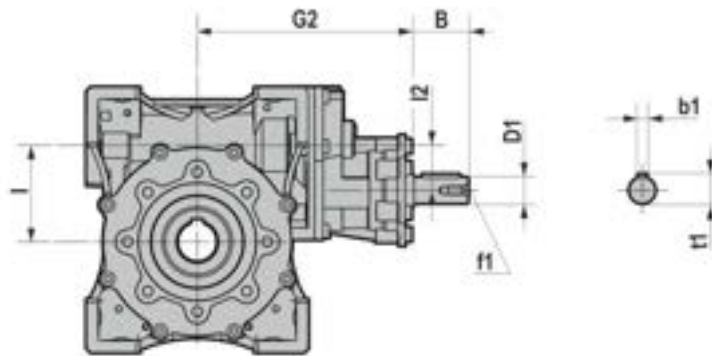

	IHW040	
	NMRV-P 090	NMRV-P 110
<b>I</b>	90	110
<b>G2</b>	204,5	227,5
<b>I2</b>	42	42
<b>B</b>	40	50
<b>D1</b>	19 j6	24 j6
<b>b1</b>	6	8
<b>t1</b>	21,5	27
<b>f1</b>	M6	M8



## 3.1.10 NMRV/NMRV-P+NMRV/NMRV-P

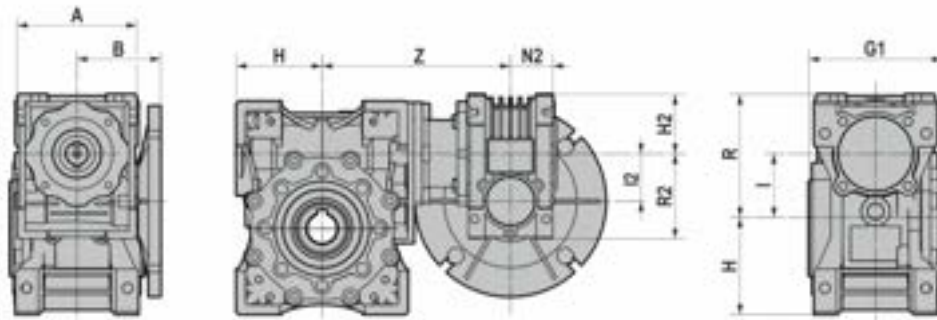

	A	G	G1	H	H1	I	R	H2	I2	N2	R2	Z
<b>025-030</b>	70	45	63	40	40	30	57	35	25	22,5	48	100
<b>025-040</b>	70	45	78	50	50	40	71,5	35	25	22,5	48	115
<b>030-040</b>	80	55	78	50	50	40	71,5	40	30	29	57	122
<b>030-050</b>	80	55	92	60	60	50	84	40	30	29	57	132
<b>030-063</b>	80	55	112	72	72	63	107	40	30	29	57	145
<b>040-050</b>	100	70	92	60	60	50	84	50	40	36,5	71,5	140,5
<b>040-063</b>	100	70	112	72	72	63	107	50	40	36,5	71,5	156,5
<b>040-075</b>	100	70	120	86	89	75	119	50	40	36,5	71,5	167,5
<b>040-090</b>	100	70	140	103	103	90	135	50	40	36,5	71,5	184,5
<b>050-075</b>	120	80	120	86	89	75	119	60	50	43,5	84	195,5
<b>050-090</b>	120	80	140	103	103	90	135	60	50	43,5	84	205
<b>050-110</b>	120	80	155	127,5	127,5	110	167,5	60	50	43,5	84	237
<b>063-075</b>	144	109	120	86	89	75	119	72	63	53	107	195,5
<b>063-090</b>	144	109	140	103	103	90	135	72	63	53	107	214
<b>063-110</b>	144	109	155	127,5	127,5	110	167,5	72	63	53	107	237
<b>063-130</b>	144	109	170	147,5	147,5	130	187,5	72	63	53	107	245
<b>063-150</b>	144	109	200	170	170	150	230	72	63	53	107	275

## 3.1.11 NRV/NRV-P+NMRV/NMRV-P

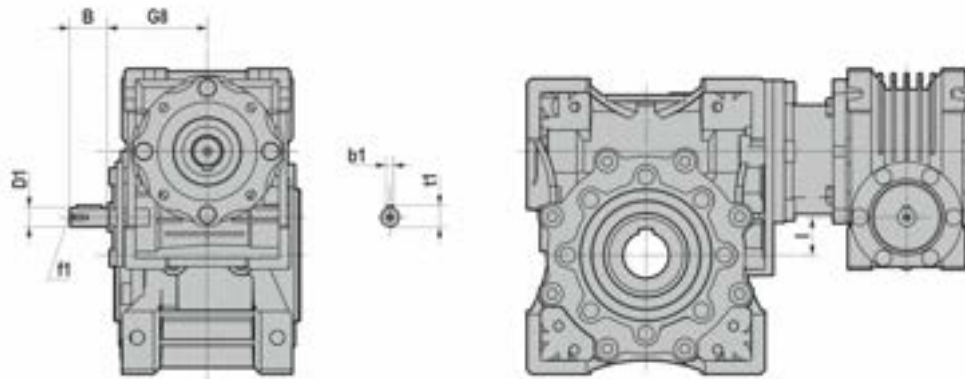

	B	D1	G8	l8	b1	fl	t1
030-040	20	9	51	10	3	-	10,2
030-050	20	9	51	20	3	-	10,2
030-063	20	9	51	33	3	-	10,2
040-050	23	11	60	10	4	-	12,5
040-063	23	11	60	23	4	-	12,5
040-075	23	11	60	35	4	-	12,5
040-090	23	11	60	50	4	-	12,5
050-090	30	14	74	40	5	M6	16
050-110	30	14	74	60	5	M6	16
063-110	40	19	90	47	6	M6	21,5
063-130	40	19	90	67	6	M6	21,5
063-150	40	19	90	87	6	M6	21,5

3.1.12 SW+SW

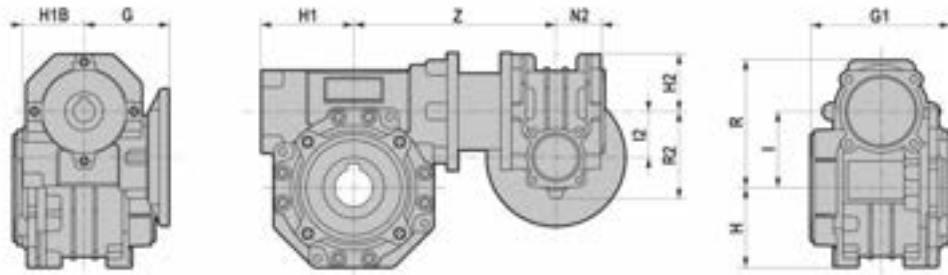

	H1B	G	G1	H	H1	I	R	H2	I2	N2	R2	Z
030-040	40	55	78	42	50	40	70	40	30	29	57	122
030-050	40	55	92	52	60	50	84	40	30	29	57	132
030-063	40	55	112	66	72	63	102	40	30	29	57	145
040-075	50	70	120	80	86	75	117	50	40	36,5	71,5	167,5
040-090	50	70	140	97	103	90	133	50	40	36,5	71,5	184,5
050-090	60	80	140	97	103	90	133	60	50	43,5	84	205
050-105	60	80	155	115	127,5	110	166	60	50	43,5	84	226

3.1.13 ISW+SW

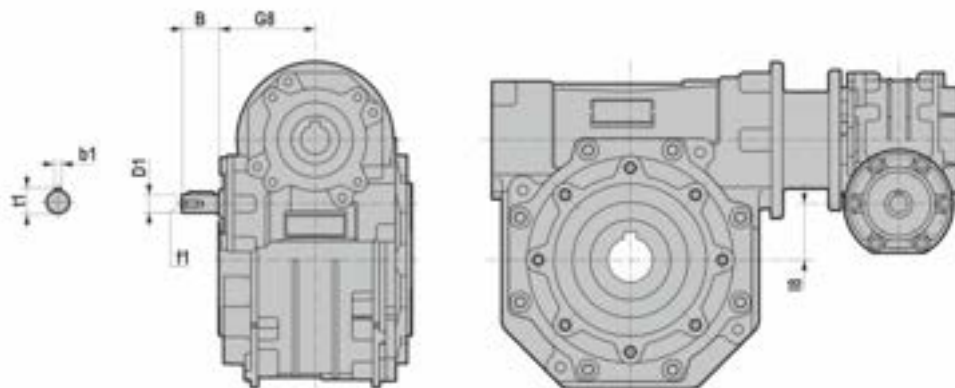

	B	D1	G8	I8	b1	f1	t1
030-040	20	9	51	10	3	-	10,2
030-050	20	9	51	20	3	-	10,2
030-063	20	9	51	33	3	-	10,2
040-075	23	11	60	35	4	-	12,5
040-090	23	11	60	50	4	-	12,5
050-090	30	14	74	40	5	M6	16
050-105	30	14	74	60	5	M6	16

### 3.2.1 Weight NMRV [kg]

The values reported in the tables are referred to the weight of the gearbox with lubricant included.  
Weight without motor.

NMRV - NMRV-P (- kg)										
025	030	040	050	063	075	090	110	130	150	
0,7	1,2	2,3	3,5	6,2	9	13	21	43,5	84	

NRV - NRV-P (- kg)										
030	040	050	063	075	090	110	130	150		
1	2	3,3	5,8	8,8	13	21	43,5	77		

	HA31+NMRV040 (- kg)	HA31+NMRV050 (- kg)
063	4,2	5,4
071	4,3	5,5
080	4,5	5,7

056/063/071/080		063/071/080/090	
NMRV-P063/HW030 (- kg)	NMRV-P075/HW030 (- kg)	NMRV-P090/HW040 (- kg)	NMRV-P110/HW040 (- kg)
7,1	10	14,6	24,4

NMRV-P090/HW040 (- kg)	NMRV-P110/HW040 (- kg)
14,6	38,4

NMRV+NMRV - NMRV+NMRV-P - NMRV-P+NMRV - NMRV-P+NMRV-P (- kg)													
025-030	025-040	030-040	030-050	030-063	040-050	040-063	040-075	040-090	050-090	050-110	063-110	063-130	063-150
1,9	3	3,5	4,7	7,4	5,8	8,5	11,3	15,3	16,5	38,5	41,2	54,2	90,2

NRV+NMRV - NRV+NMRV-P - NRV-P+NMRV - NRV-P+NMRV-P (- kg)											
030-040	030-050	030-063	040-050	040-063	040-075	040-090	050-090	050-110	063-110	063-130	063-150
3,5	4,7	7,4	5,8	8,5	11,3	15,3	16,5	38,5	41,2	54,2	90,2

### 3.2.2 Weight SW [kg]

The values reported in the tables are referred to the weight of the gearbox with lubricant included.  
Weight without motor.

SW (- kg)						
030	040	050	063	075	090	105
1,2	2,3	3,5	6,2	9	13	21

ISW (- kg)						
030	040	050	063	075	090	105
1	2	3,3	5,8	8,8	13	21

	HA31+SW040 (- kg)	HA31+SW050 (- kg)	HA31+SW063 (- kg)	HA31+SW075 (- kg)	HA31+SW090 (- kg)
063	4,2	5,4	8,1	10,9	14,9
071	4,3	5,5	8,2	11,0	15,0
080	4,5	5,7	8,4	11,2	15,2

SW+SW (- kg)					
030-040	030-050	030-063	040-075	040-090	050-105
3,5	4,7	7,4	11,3	15,3	38,5

ISW+SW (- kg)					
030-040	030-050	030-063	040-075	040-090	050-105
3,5	4,7	7,4	11,3	15,3	38,5

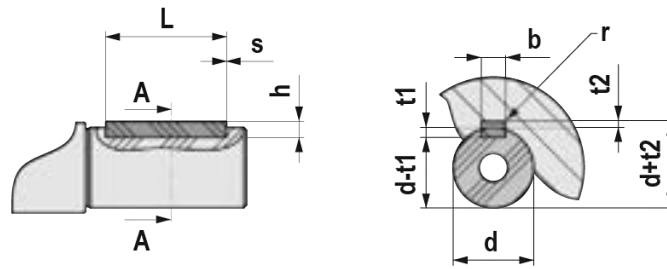

UNI 6604 - DIN 6885														
d		b x h			Tol. b/h	L		$\frac{s}{\min / \max}$	b	t1	t2	Tol. t1/t2	r max	
	6	8	2	x	2	h9/h9	6	20	0,16 0,25	2	1,2	0,1 0	0,08 0,16	
>	8	10	3	x	3		6	36		3	1,8			1,4
>	10	12	4	x	4		8	45		4	2,5			1,8
>	12	17	5	x	5		10	56	5	3	2,3	0,16 0,25		
>	17	22	6	x	6		14	70	6	3	2,8			
>	22	30	8	x	7	h9/h11	18	90	0,25 0,4	8	4	3,3	0,25 0,4	
>	30	38	10	x	8		22	110		10	5	3,3		
>	38	44	12	x	8		28	140		12	5	3,3		
>	44	50	14	x	9		36	160	14	5,5	3,8	0,2 0		
>	50	58	16	x	10		45	180	16	6	4,3			
>	58	65	18	x	11		50	200	18	7	4,4			
>	65	75	20	x	12		56	110	20	7,5	4,9	0,4 0,6		
>	75	85	22	x	14		63	140	22	9	5,4			
>	85	95	25	x	14		70	160	25	9	5,4			
>	95	110	28	x	16		80	180	28	10	6,4			
>	110	130	32	x	18		90	200	32	11	7,4			
>	130	150	36	x	20		100	160	36	12	8,4	0,3 0	0,7 1	
>	150	170	40	x	22		110	180	40	13	9,4			
>	170	200	45	x	25		125	200	45	14	10,4			

3.4.1 Electric motors

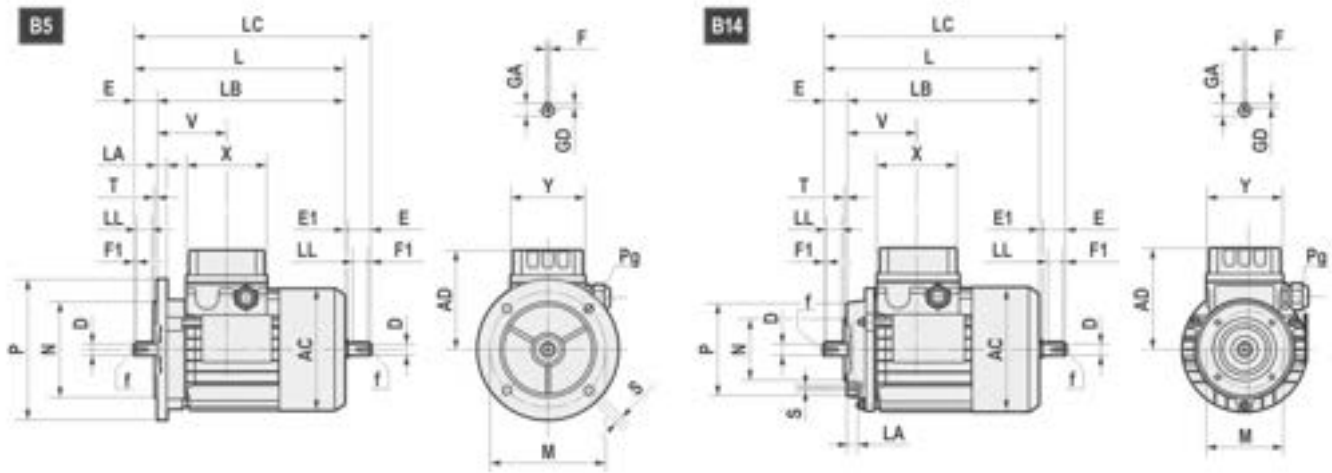

	AC	AD	L	LB	LC	X	Y	V	D	E	E1	f	F1	GA	F	GD
<b>63</b>	121	104	211	188	235,5	80	74	69	11 j6	23	1,5	M4x10	2,5	12,5	4	4
<b>71</b>	139	112	238,5	208,5	271	80	74	74,5	14 j6	30	2,5	M5x12,5	3	16	5	5
<b>80</b>	158	122	272,5 *296	232,5 *256	314 *337	80	74	78	19 j6	40	1,5	M6x16	5	21,5	6	6
<b>90S</b>	173	148	298 *331	248 *281	349,5 *381	98	98	89,5	24 j6	50	1,5	M8x19	5	27	8	7
<b>90L</b>	173	148	323 *356	273 *306	374,5 *408	98	98	89,5	24 j6	50	1,5	M8x19	5	27	8	7
<b>100</b>	191	156	368	308	431,5	98	98	97,5	28 j6	60	3,5	M10x22	7,5	31	8	7
<b>112</b>	211	171	382,5 *408	322,5 *348	447 *472	98	98	100	28 j6	60	3,5	M10x22	7,5	31	8	7
<b>132S</b>	249	195	452	372	536,5	118	118	115,5	38 k6	80	4	M12x28	10	41	10	8
<b>132L</b>	249	195	490	410	574,5	118	118	115,5	38 k6	80	4	M12x28	10	41	10	8
<b>160S</b>	249	195	520	410	/	118	118	115,5	42k6	100	/	M16x36	10	45	12	8

\*TP80B4, SH80B4, HSH80B4, TP90S4, SH90S4, HSH90S4, TP90L4, SH90L4, HSH90L4, TP90S6, TP112M4, TP112M6

B5	M	N	P	LA	S	T
<b>63</b>	115	95	140	10	9	3
<b>71</b>	130	110	160	10	9,5	3,5
<b>80</b>	165	130	200	12	11	3,5
<b>90</b>	165	130	200	12	11	3,5
<b>100</b>	215	180	250	15	14	4
<b>112</b>	215	180	250	14,5	14	4
<b>132</b>	265	230	300	20	14	3,5
<b>160</b>	300	250	350	13	18,5	3,5

B14	M	N	P	LA	S	T
<b>63</b>	75	60	90	10	M5	2,5
<b>71</b>	85	70	105	10,5	M6	2,5
<b>80</b>	100	80	120	10,5	M6	3
<b>90</b>	115	95	140	11,5	M8	3
<b>100</b>	130	110	160	15	M8	3,5
<b>112</b>	130	110	160	11,5	M8	3,5
<b>132</b>	165	130	200	20,5	M10	3,5
<b>160</b>	215	180	250	-	M12	4

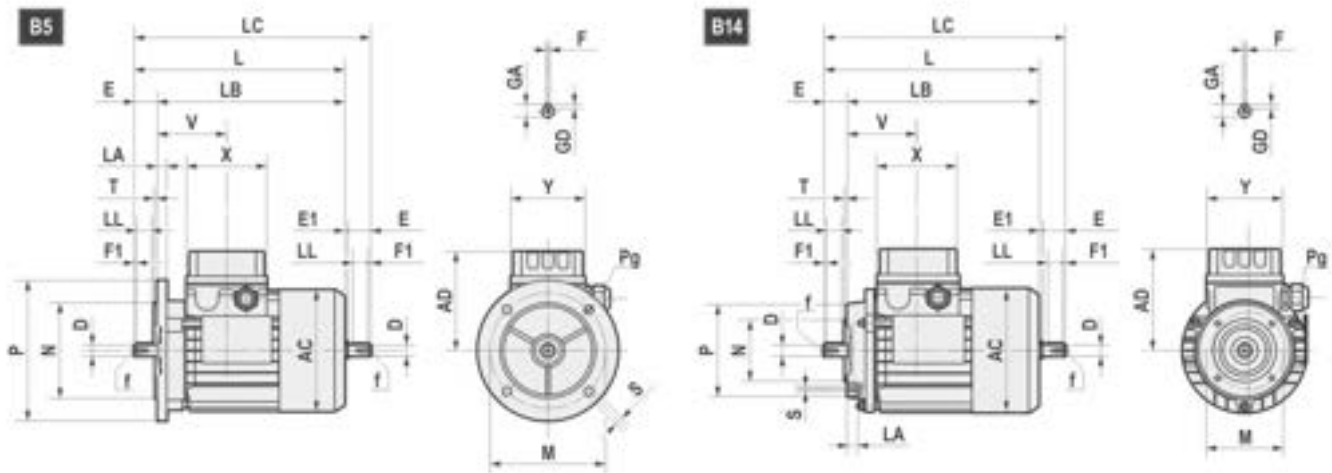

		AC	AD	L	LB	X	D	E	f	GA	F	GD	LL	Pg	
<b>160M</b>	2-4-6	314	251	600	490	158	42	110	M16	45	12	8	90	2-M40x1,5	1-M16x1,5
<b>160L</b>	2-4-6	314	251	645	535	158	42	110	M16	45	12	8	90	2-M40x1,5	1-M16x1,5
<b>180M</b>	2-4	355	267	680	570	158	48	110	M16	51,5	14	9	100	2-M40x1,5	1-M16x1,5
<b>180L</b>	4-6	355	267	720	610	158	48	110	M16	51,5	14	9	100	2-M40x1,5	1-M16x1,5
<b>200L</b>	2-4-6	397	300	785	675	187	55	110	M20	59	16	10	100	2-M50x1,5	1-M16x1,5
<b>225S</b>	4	446	325	820	680	187	60	140	M20	64	18	11	125	2-M50x1,5	1-M16x1,5
<b>225M</b>	2	446	325	815	705	187	55	110	M20	59	16	10	100	2-M50x1,5	1-M16x1,5
<b>225M</b>	4-6	446	325	845	705	187	60	140	M20	64	18	11	125	2-M50x1,5	1-M16x1,5
<b>250M</b>	2-4-6	485	360	910	770	238	60	140	M20	64	18	11	125	2-M63x1,5	1-M16x1,5
<b>250M</b>	2-4-6	485	360	910	770	238	65	140	M20	69	18	11	125	2-M63x1,5	1-M16x1,5
<b>280S</b>	2-4-6	547	390	970	830	238	65	140	M20	69	18	11	125	2-M63x1,5	1-M16x1,5
<b>280S</b>	2-4-6	547	390	970	830	238	75	140	M20	79,5	20	12	125	2-M63x1,5	1-M16x1,5
<b>280M</b>	2-4-6	547	390	1025	885	238	65	140	M20	69	18	11	125	2-M63x1,5	1-M16x1,5
<b>280M</b>	2-4-6	547	390	1025	885	238	75	140	M20	79,5	20	12	125	2-M63x1,5	1-M16x1,5

B5	M	N	P	LA	S	T
<b>160</b>	300	250	350	13	19	5
<b>180</b>	300	250	350	15	19	5
<b>200</b>	350	300	400	17	19	5
<b>225</b>	400	350	450	20	19	5
<b>250</b>	500	450	550	22	19	5
<b>280</b>	500	450	550	22	19	5

### 3.4.2 Standard high efficiency (TS), high (TH, SH, HSH) and premium (TP) motors

Motovario, three-phase, single polarity motors are available in three different versions (IE1-IE2-IE3) in compliance with standard 60034-30-1. The efficiency value is calculated according to the method set forth in standard IEC 60034-2-1.

1. IE1: TS series (standard efficiency) for nominal power less than 0.12 kW.;
2. IE2: TH series (high efficiency) for nominal power greater than or equal to 0.12 kW and less than 0.75 kW;
3. IE3: TP series (premium efficiency) (\*) 4 poles for nominal power greater than or equal to 0.12 kW, 2 and 6 poles for nominal power greater than or equal to 0.75 kW.

Motovario single-phase, single-polarity motors are available in IE2 efficiency class according to IEC 60034-30-1 for nominal power ratings higher than or equal to 0.12 kW and lower than or equal to 2.2 kW. The efficiency value is calculated according to the method set forth in standard IEC 60034-2-1.

Table of Motovario commercial availability

NOMINAL POWER [kW]	EFFICIENCY LEVEL		
	IE1	IE2	IE3
$P_n < 0,12$	TS-TBS	-	-
$0,12 \leq P_n < 0,75$	-	TH-TBH SH-HSH	TP-TBP (**)
$P_n \geq 0,75$	-	SH-HSH	TP-TBP

(\*) Motor TP100LA4 2,2 kW and all TP 6 poles motors are available at 60Hz only upon request. As a consequence, these motors are in IE3 efficiency level at 50 Hz and IE2 at 60 Hz in case of bifrequency electrical design (standard 230/400-265/460V 50-60Hz and optional 200/346-220/380V 50-60Hz, 290/500-330/575V 50-60Hz and 400/690-460/800V 50-60Hz, see chapter on input voltage and frequency).

(\*\*) Only 4 poles.



3.4.3 Nominal power - [kW]

P.	63A			63B		63C	63D	71A		71B		71C
	TS	TH	TP	TH	TP	TH	TH	TH	TP	TH	TP	TH
2	-	0,18	-	0,25	-	0,37	-	0,37	-	0,55	-	-
4	-	0,12	0,12	0,18	0,18	-	0,25	0,25	0,25	0,37	0,37	0,55
6	0,09	-	-	0,12	-	-	-	0,18	-	0,25	-	0,37

P.	80A		80B		90S	90L	100LR	100LA	100L	112MR	112MS	112M
	TH	TP	TH	TP	TP	TP	TP	TP	TP	TP	TP	TP
2	-	0,75	-	1,1	1,5	2,2	-	-	3	-	-	4
4	0,55	0,55	-	0,75	1,1	1,5	-	2,2	-	2,2	3	4
6	0,37	-	0,55	-	0,75	-	1,1	-	1,5	-	-	2,2

P.	132S	132MS	132MA	132MB	132M
	TP	TP	TP	TP	TP
2	5,5	-	-	-	7,5
4	-	5,5	-	-	7,5
6	3	-	4	5,5	-

P.	160M	160MA	160MB	160L	160LA	180M	180L
	TP	TP	TP	TP	TP	TP	TP
2	-	11	15	18,5	-	22	-
4	-	11	-	-	15	18,5	22
6	7,5	-	-	11	-	-	15

P.	200L	200LA	200LB	225S	225M	250M	280S	280M
	TP	TP	TP	TP	TP	TP	TP	TP
2	-	30	37	-	-	-	-	-
4	30	-	-	37	45	55	75	90
6	-	18,5	22	-	-	-	-	-

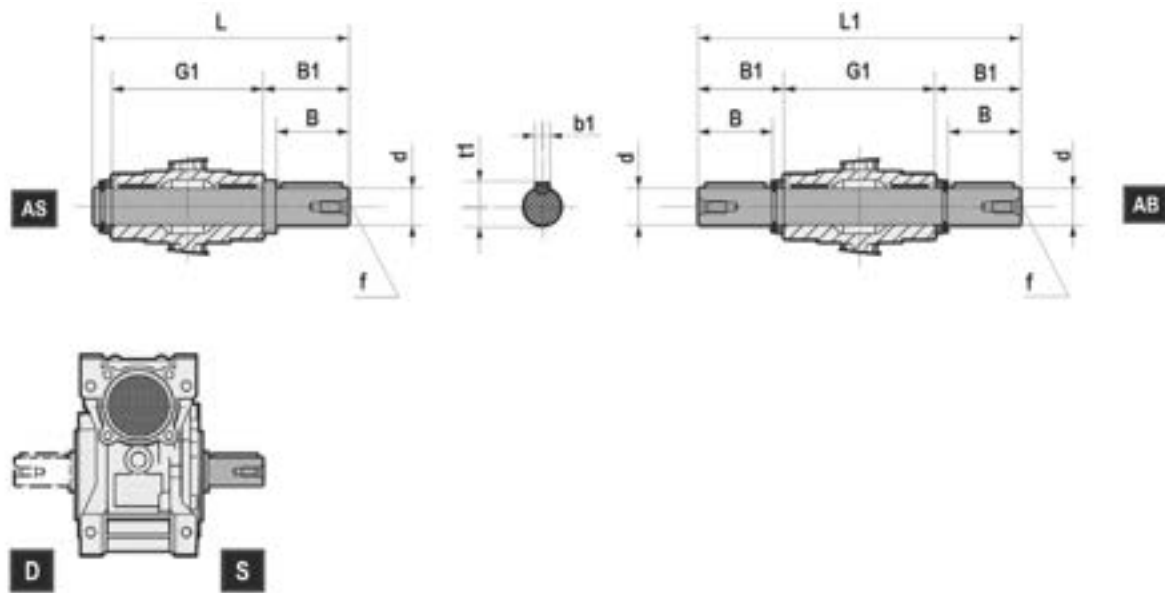

		d	B	B1	G1	L	L1	f	b1	t1
NMRV	025	11g6 ( 9 )	23 ( 25 )	25,5 ( 30 )	50	81 ( 85,5 )	101 ( 110 )	-	4 ( 3 )	12,5 ( 10,2 )
NMRV SW	030	14 h6	30	32,5	63	102	128	M6	5	16
NMRV SW	040	18 h6	40	43	78	128	164	M6	6	20,5
NMRV SW	050	25 h6	50	53,5	92	153	199	M10	8	28
NMRV-P SW	063	25 h6	50	53,5	112	173	219	M10	8	28
NMRV-P SW	075	28 h6	60	63,5	120	192	247	M10	8	31
NMRV-P SW	090	35 h6	80	84,5	140	234	309	M12	10	38
SW	105	42 h6	80	84,5	155	249	309	M16	12	45
NMRV-P	110	42 h6	80	84,5	155	249	324	M16	12	45
NMRV	130	45 h6	80	85	170	265	340	M16	14	48,5
NMRV	150	50 h6	82	87	200	297	374	M16	14	53,5

4.2 OUTPUT FLANGE

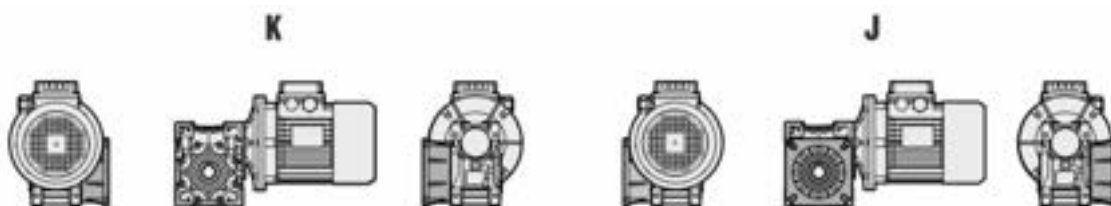

Unless specified otherwise, the reduction unit is supplied with the flange in pos. J referred to position B3.

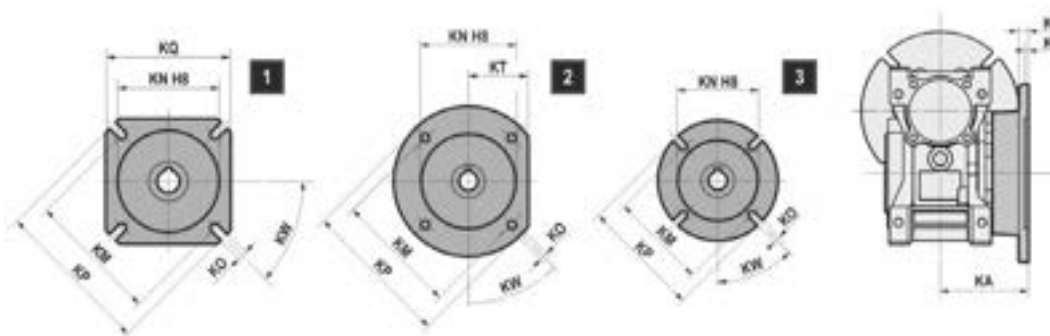

	NMRV - SW	NMRV - SW	NMRV - SW	NMRV-P - SW	NMRV-P - SW	NMRV-P - SW	SW	NMRV-P	NMRV	NMRV
	030	040	050	063	075	090	105	110	130	150
FA	1	1	1	1	1	1	1	1	1	1
FB	-	1	1	1	3	2	1	1	-	-
FC	-	2	2	2	-	3	-	-	-	-
FD	-	2	2	2	-	1	-	-	-	-
FE	-	-	-	3	-	-	-	-	-	-

		FA									FB									
		KA	KB	KC	KN	KM	KO	KP	KQ	KW	KA	KB	KC	KN	KM	KO	KP	KQ	KT	KW
NMRV - SW	030	54,5	6	4	50	68	6.5 (n <sup>o</sup> 4)	80	70	45°	-	-	-	-	-	-	-	-	-	-
NMRV - SW	040	67	7	4	60	80 min	9 (n <sup>o</sup> 4)	110	95	45°	97	7	4	60	80 min	9 (n <sup>o</sup> 4)	110	95	-	45°
NMRV - SW	050	90	9	5	70	90 min	11 (n <sup>o</sup> 4)	125	110	45°	120	9	5	70	90 min	11 (n <sup>o</sup> 4)	125	110	-	45°
NMRV-P - SW	063	82	10	6	115	150	11 (n <sup>o</sup> 4)	180	142	45°	112	10	6	115	150	11 (n <sup>o</sup> 4)	180	142	-	45°
NMRV-P - SW	075	111	13	6	130	165	14 (n <sup>o</sup> 4)	200	170	45°	90	13	6	110	130	11 (n <sup>o</sup> 4)	160	-	-	45°
NMRV-P - SW	090	111	13	6	152	175	14 (n <sup>o</sup> 4)	210	200	45°	122	18	6	180	215	14 (n <sup>o</sup> 4)	250	-	105	45°
SW	105	131	15	6	170	230	14 (n <sup>o</sup> 8)	280	260	45°	180	15	6	170	230	14 (n <sup>o</sup> 8)	280	260	-	45°
NMRV-P	110	131	15	6	170	230	14 (n <sup>o</sup> 8)	280	260	45°	180	15	6	170	230	14 (n <sup>o</sup> 8)	280	260	-	45°
NMRV	130	140	15	6	180	255	16 (n <sup>o</sup> 8)	320	290	22.5°	-	-	-	-	-	-	-	-	-	-
NMRV	150	155	15	6	180	255	16 (n <sup>o</sup> 8)	320	290	22.5°	-	-	-	-	-	-	-	-	-	-

		FC									FD									
		KA	KB	KC	KN	KM	KO	KP	KT	KW	KA	KB	KC	KN	KM	KO	KP	KQ	KT	KW
NMRV - SW	040	80	9	5	95	115	9.5 (n <sup>o</sup> 4)	140	56	45°	58	12	5	80	100	9 (n <sup>o</sup> 4)	120	-	50	45°
NMRV - SW	050	89	10	5	110	130	9.5 (n <sup>o</sup> 4)	160	66	45°	72	14,5	5	95	115	11 (n <sup>o</sup> 4)	140	-	60	45°
NMRV-P - SW	063	98	10	5	130	165	11 (n <sup>o</sup> 4)	200	80	45°	107	10	5	130	165	11 (n <sup>o</sup> 4)	200	-	80	45°
NMRV-P - SW	090	110	17	6	130	165	11 (n <sup>o</sup> 4)	200	-	45°	151	13	6	152	175	14 (n <sup>o</sup> 4)	210	200	-	45°

		FE							
		KA	KB	KC	KN	KM	KO	KP	KW
NMRV-P - SW	063	80,5	16,5	5	110	130	11 (n <sup>o</sup> 4)	160	45°

4.3.1 Torque arm: Mounting position

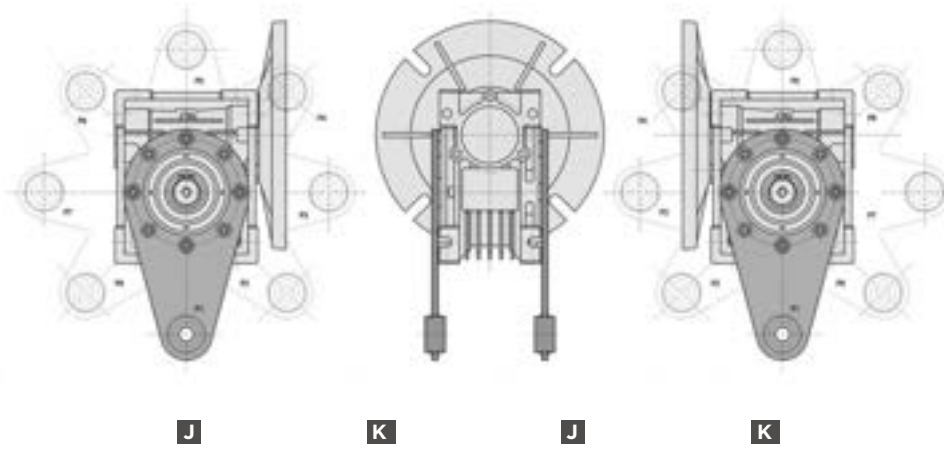

NMRV NMRV-P NMRL	P1		P2		P3		P4		P5		P6		P7		P8	
	J	K	J	K	J	K	J	K	J	K	J	K	J	K	J	K
025			/	/	NO	NO	/	/			/	/			/	/
030			NO	NO	NO	NO	NO	NO								
040	NO NMRL		NO	NO	NO	NO	NO	NO	NO NMRL		NO NMRL		NO NMRL		NO NMRL	
050			NO	NO	NO	NO	NO	NO			NO	NO				
063					NO	NO	NO	NO								
075			NO	NO	NO	NO	NO	NO								
090					NO	NO	NO	NO								
110					NO	NO	NO	NO								
130					NO	NO	NO	NO								
150			NO	NO	NO	NO	NO	NO	NO	NO	NO	NO			NO	NO

SW SWL	P1		P2		P3		P4		P5		P6		P7		P8	
	J	K	J	K	J	K	J	K	J	K	J	K	J	K	J	K
030			NO	NO	NO	NO	NO	NO								
040	NO SWL		NO	NO	NO	NO	NO	NO	NO SWL		NO SWL		NO SWL		NO SWL	
050			NO	NO	NO	NO	NO	NO			NO	NO				
063					NO	NO	NO	NO								
075			NO	NO	NO	NO	NO	NO								
090					NO	NO	NO	NO								
105					NO	NO	NO	NO								

(/) Not available

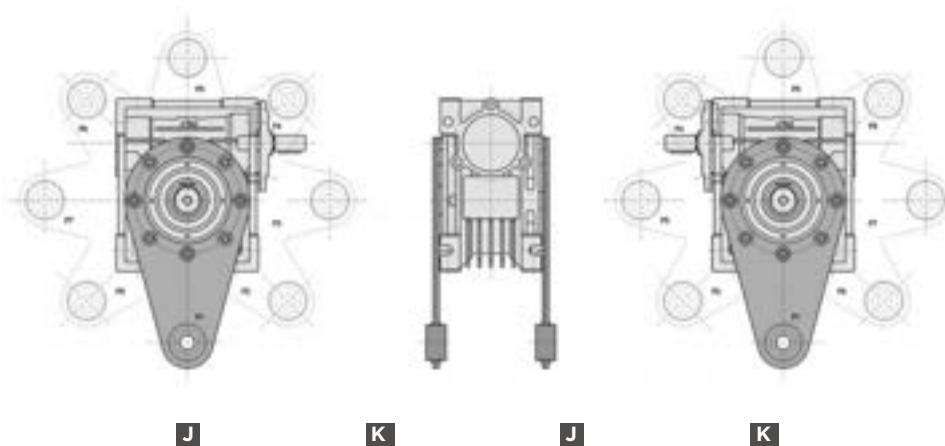

NRV NRV-P NRL	P1		P2		P3		P4		P5		P6		P7		P8		
	J	K	J	K	J	K	J	K	J	K	J	K	J	K	J	K	
030			NO	NO			NO	NO									
040	NO NRL		NO NRL	NO	NO NRL	NO	NO	NO	NO NRL		NO NRL		NO NRL		NO NRL		
050			NO	NO			NO	NO			NO	NO					
063							NO	NO									
075							NO	NO									
090							NO	NO									
110							NO	NO									
130							NO	NO									
150			NO	NO			NO	NO	NO	NO	NO	NO				NO	NO

ISW SWL	P1		P2		P3		P4		P5		P6		P7		P8		
	J	K	J	K	J	K	J	K	J	K	J	K	J	K	J	K	
030			NO	NO	NO	NO	NO	NO									
040	NO SWL		NO	NO	NO	NO	NO	NO	NO SWL		NO SWL		NO SWL		NO SWL		
050			NO	NO	NO	NO	NO	NO			NO	NO					
063					NO	NO	NO	NO									
075			NO	NO	NO	NO	NO	NO									
090					NO	NO	NO	NO									
105					NO	NO	NO	NO									

(/) Not available

For information on torque arm mounting positions on combined worm gear reducers and worm gear reducers with pre-stage units, please contact our Technical Service.

## 4.3.2 Torque arm: Dimensions

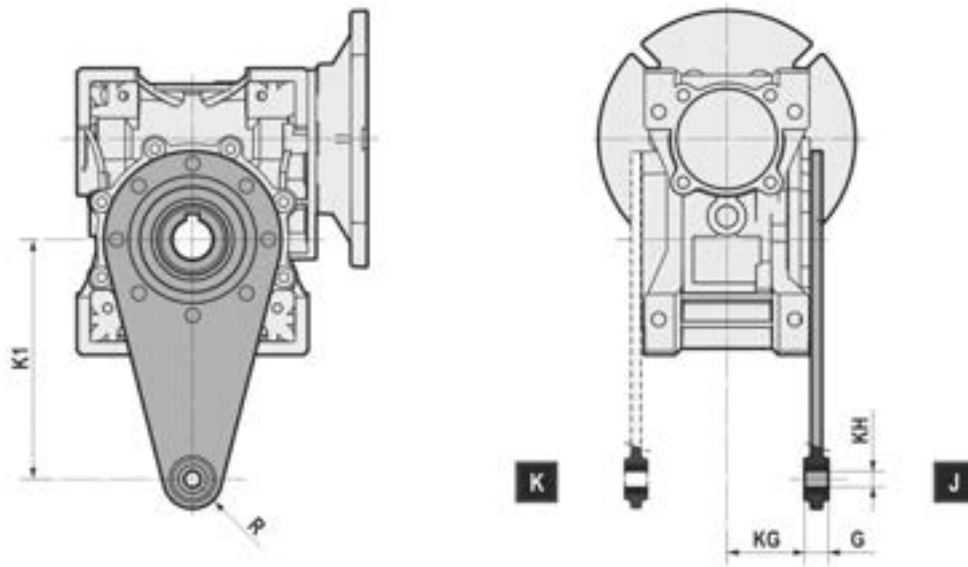

NMRV NMRV-P SW	025	030	040	050	063	075	090	105	110	130	150
K1	70	85	100	100	150	200	200	250	250	250	250
G	14	14	14	14	14	25	25	30	30	30	30
KG	17,5	24	31,5	38,5	49	47,5	57,5	62	62	69	84
KH	8	8	10	10	10	20	20	25	25	25	25
R	15	15	18	18	18	30	30	35	35	35	35

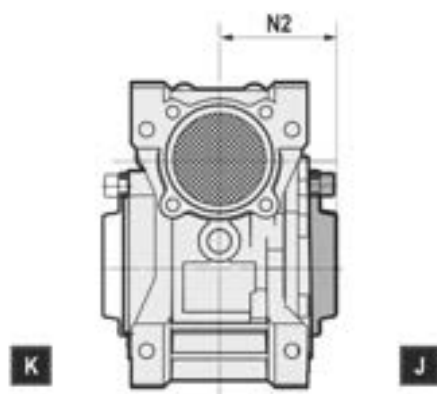

NMRV NMRV-P SW	N2
030	42
040	50
050	57,5
063	68,5
075	73,5
090	85,5
105	94
110	94
130	102
150	117

## 4.5.1 Dimensions

The torque limiter is available for worm gearbox type NMRL050, SWL040, SWL050, SWL063, SWL075, SWL090 in J position only. The MTV torque limiter is univocally supplied for every gear unit with the hollow output shaft diameter equal to dimension D shown in the table. Different diameters could be provided upon request, after technical and manufacturing control. Upon request it's possible to assemble an output solid shaft kit, different from the standard one available in the catalogue.

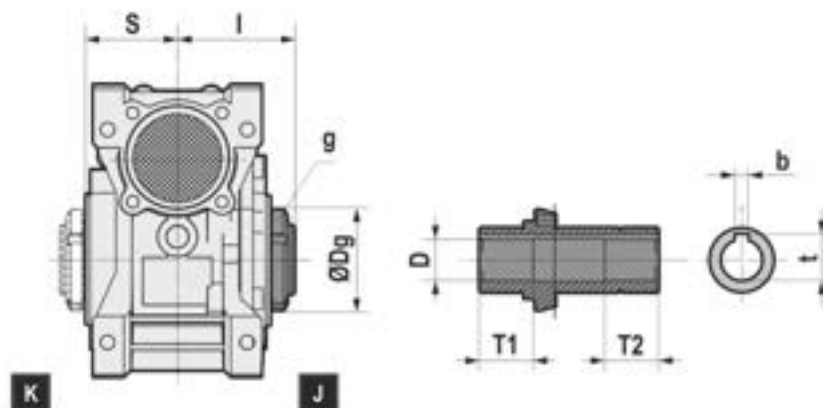

	NMRL			
	050	063	075	090
I	63,5	74	78,5	89,5
S	46	56	60	70
Dg	56	62	68	80
g	M40x1,5	M45x1,5	M50x1,5	M60x2
b	8	8	8	10
t	28,3	28,3	31,3	38,3
D	25	25	28	35
T1	33	37	40	45
T2	33	37	40	45

	SWL				
	040	050	063	075	090
I	55	63,5	74	78,5	89,5
S	39	46	56	60	70
Dg	44	56	62	68	80
g	M30x1,5	M40x1,5	M45x1,5	M50x1,5	M60x2
b	6	8	8	8	10
t	20,8	28,3	28,3	31,3	38,3
D	18	25	25	28	35
T1	28	33	35	40	45
T2	28	33	37	40,5	45



### 4.5.2 Operating principle

In this mechanical device the transmission of movement takes place by means of friction between the driving surface (input shaft (10)) and the driven surface (wormwheel (9)). These are subject of a determined compression created by the plate (7) which is generated by two belleville washers (6), arranged in series. The belleville washers action is generated by the bushing (3), driven by the external locking ring nut (1) which is screwed on the output shaft. The shift (X) is guaranteed by the connection between the two conical elements of the hub (2) and the worm wheel.

The transmission of movement has a standard operation up to a maximum admissible torque value (slip torque); over this value the torque limiter starts to work generating a slip between the worm wheel, which continues to spin conducted by the input shaft, and the hub which remains still. Over the slip torque expected from the regulation, the torque limiter is still "on hold": it transmits the set value and it doesn't transmit higher values. This ensures to the machine to restart automatically without external action.

For safety reasons it isn't recommended to install this device in lifting equipment: in case of overloads or irregularities, during the shift, the weight could not be maintained in suspension.

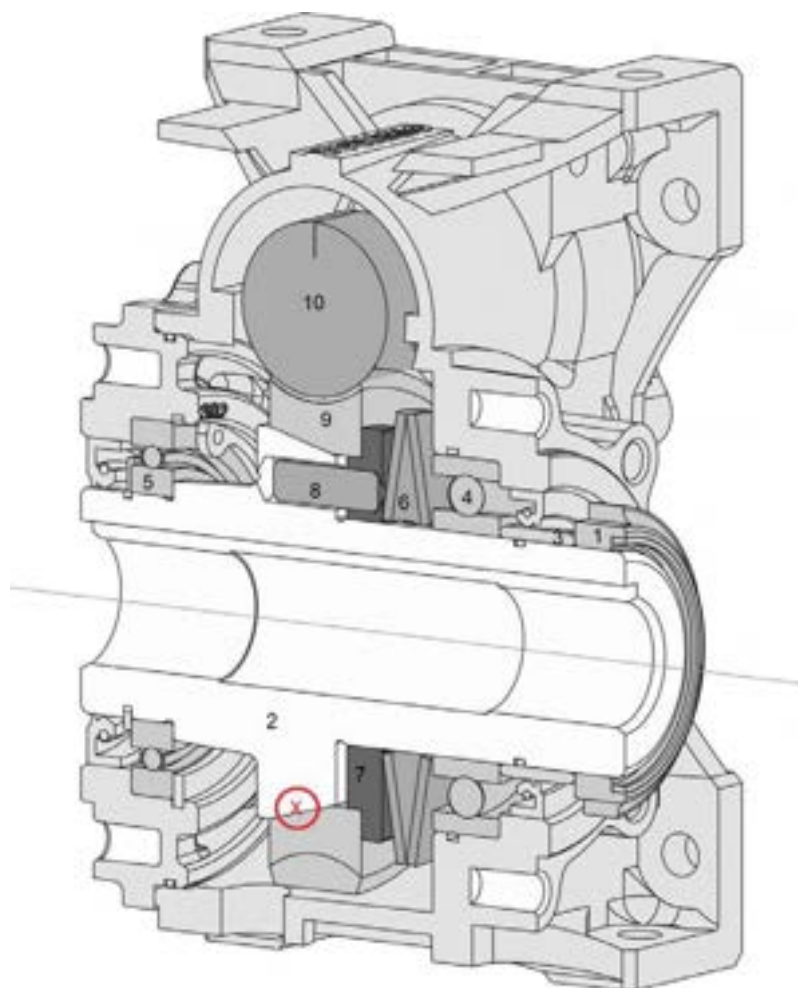

### 4.5.3 Description

The torque limiter is a mechanical device designed to protect the transmission from movement caused by accidental overloads or irregularities. It is applied to the output of the worm gear reducers and it works as an internal friction applied on the output shaft, which can be adjusted manually through an external locking ring nut. Compared to electronic or external mechanical devices, this solution presents the following advantages:

- Limited additional dimensions compared to the version without the torque limiter;
- Hollow output shaft without changes in terms of diameter compared to the standard version;
- Quick action directly on the transmission that must be protected;
- It has been designed for oil-bath operation, therefore wear-free and reliable;
- Manual adjustment of the slip torque;
- Over the slip torque, the torque limiter is still “on hold”, ensuring the automatic machine restart without external intervention;
- Using the torque limiter, it 's possible also to rotate the gearbox shaft by loosening the external locking ring nut, for example in case of mechanical locks due to worm irreversibility.

**The torque limiter device must to be installed as a protection system for accidental events and not as protection of wrong gearbox selection** (for example after selecting a gearbox with a low service factor compared with the real needs of the application).

The torque limiter is available for worm gear reducers type NMRL050 / NMRL-P063-075-090 / SWL040-050-063-075-090 and it is applicable in all combined unit configurations provided in the catalogue, usually on the last gearbox. The torque limiter is supplied on the gearbox output shaft in J or K position.

### 4.5.4 Slip torque setting

A slip torque setting is easily adjustable from the outside through the rotation of the locking ring nut, characterized by 4 marks to define the number of turns (each mark is equivalent to  $\frac{1}{4}$  of a turn). The device is preliminary set during the assembly phase. The following factors may affect the setting: temperature and period of adjustment. It is therefore recommended, during the installation, to actually verify the slip torque limit, in according to the real needs of the application.

**The standard direction of rotation for the registration of the ring nut is clockwise. Looking frontally from the ring nut side, the torque limiter is in J position when the motor position is on the right side; with the motor on left side the torque limiter is in K position.**

*It's recommended for long stops, even if the machine restarts automatically, to return the ring nut to its original position and to set it again.*

As previously mentioned, for each reducers size (040-050-063-075-090) the slip torque range depends by the ratio and the direction of rotation of the gearbox, which affects the tolerances between the two conical components that generate the slip (there is an axial component which tends to approach or move their away). Therefore in the setting diagrams are shown two lines which represent the approximate limits within the provided slip torque could change. The slip torque setting must be always checked afterward to determine if the number of turns of the ring nut guarantees the desired slip torque value.

	Ring nut rotation
<b>040</b>	1/2 (turn)
<b>050</b>	1/2 (turn)
<b>063</b>	3/4 (turn)
<b>075</b>	1 (turn)
<b>090</b>	1 (turn)

### 4.5.5 Adjustment graphs

IMP: the values (1/4, 1/2, 3/4, 1, 1 1/4 ...) correspond to the center of the column.

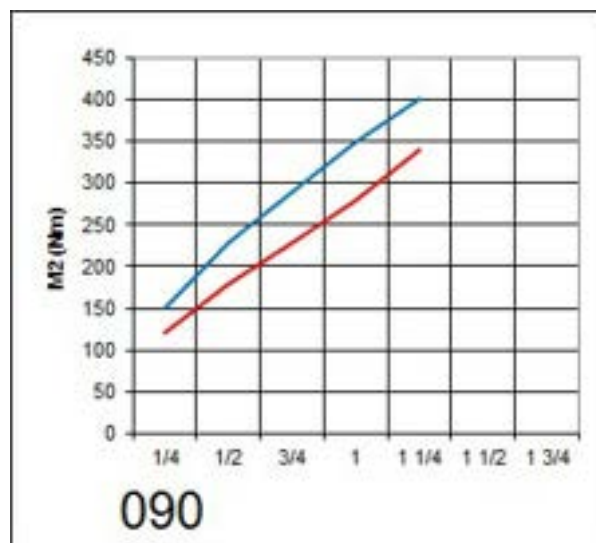
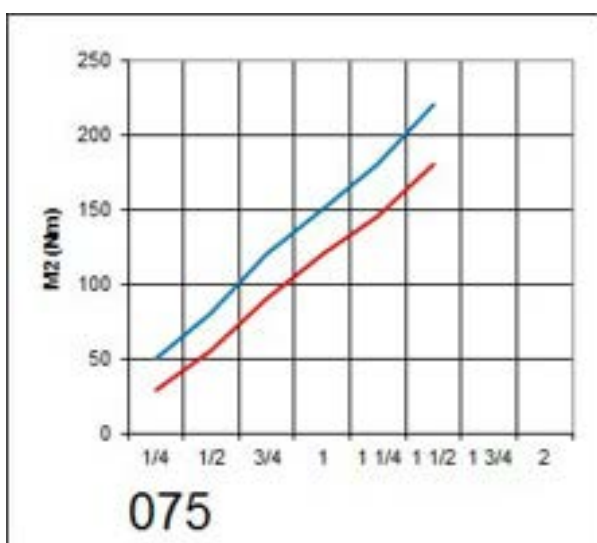
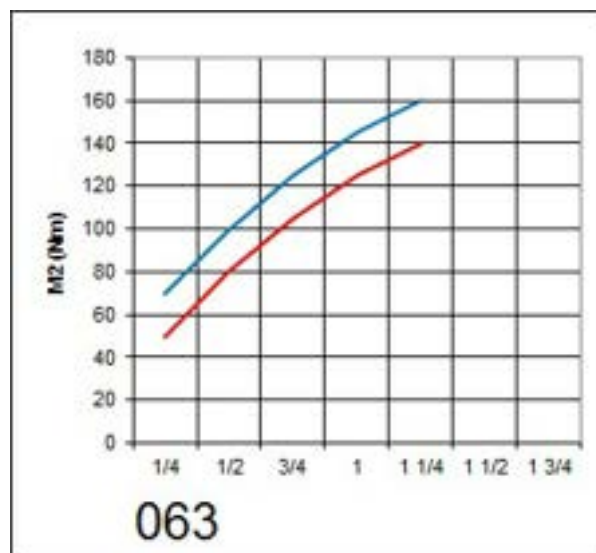
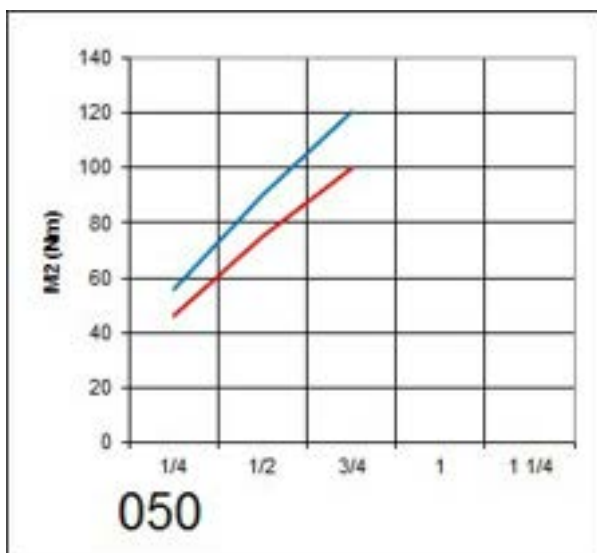
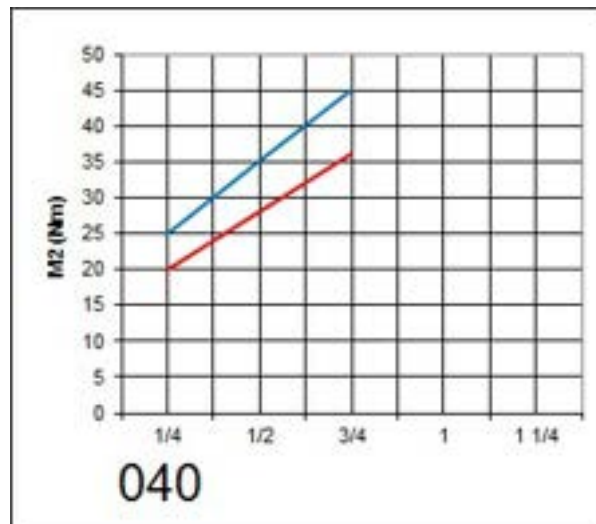
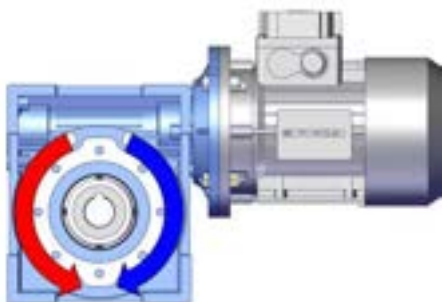

### 4.6.1 Application description

CLEAN DUTY is a solution developed by Motovario for the food industry and for all fields of application that require very high standards of hygiene. Clean Duty is made of AISI stainless steel and has been properly treated to prevent water and dirt from stagnating and depositing.

Clean Duty is a gearmotor ideally suited to the primary processing stage, for example on the packaging lines for fruit and other fresh foods. Its compact size and high-quality surface treatments ensure high resistance, especially in corrosive environments.

#### TECHNICAL CHARACTERISTICS

Compact size, adaptability and corrosion-proof materials are the technical characteristics of the Clean Duty gearmotor. Groups available with motor coupling flanges B14. For B5 flanges call MOTOVARIO TECHNICAL SERVICE.

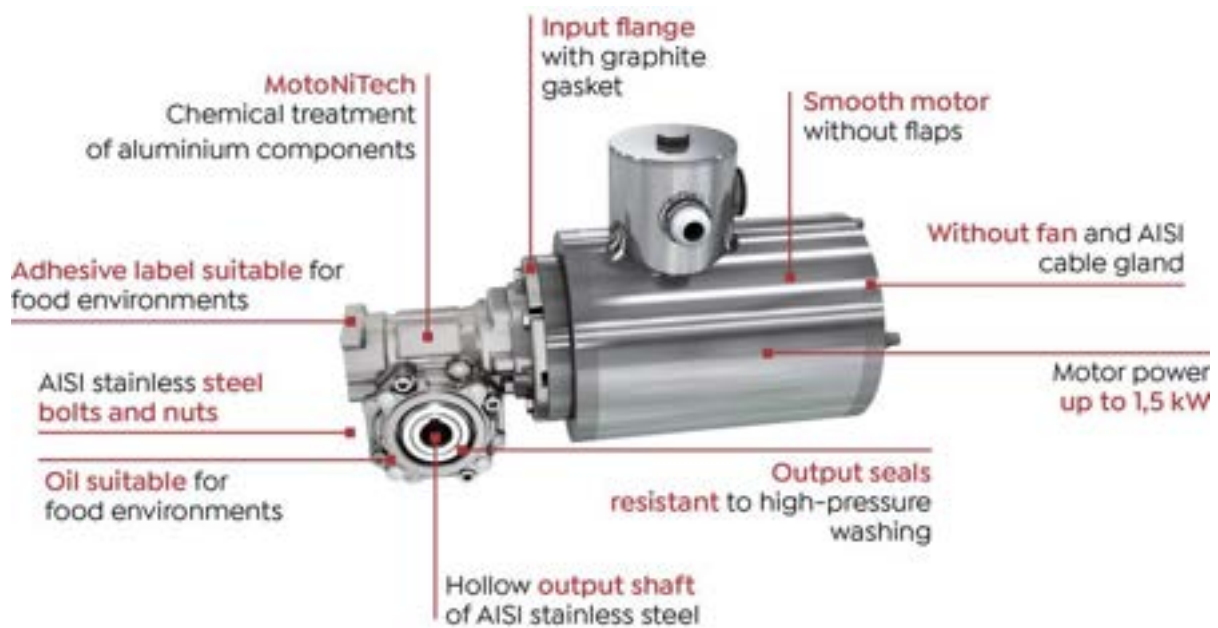

### 4.6.2 Solutions

The food industry requires high standards of hygiene in all phases of work. The processes of cutting, slicing, dosing, packaging and temperature control (hot or cold) can be supported by the Clean Duty gearmotor made by Motovario, since the aluminium surfaces are chemically treated to ensure high resistance to washing with products with a pH ranging from 2 to 12, as well as with high pressure water. Motors have smooth surfaces with IP66 protection grade. Clean Duty adapts to various configurations and arrangement options.

	SOLUTION	SW-CD/A	SW-CD/C	SW-CD/D
CASING TREATMENT	Blu RAL 5010 / Not painted	Standard	/	/
	MotoNiTech TNC17 (Chemical treatment)	/	Standard	Standard
OUTPUT SHAFT	Stainless steel	Standard	Standard	Standard
BOLTS AND NUTS	Stainless steel	Standard	Standard	Standard
LUBRICANT / OIL SEAL	Food grade lubricant	Option	/	Standard
	High pressure oil seal	Option	/	Standard
MOTOR	Standard motor	Standard	/	/
	Stainless steel motor	/	Standard	Standard

/ - Not available

### 4.6.3 Surface treatment

The surface treatment of the Clean Duty gearmotor makes it ideal for the food industry.

#### MotoNiTech Treatment

Thanks to the high chemical resistance of the coating and the complete coverage of the surface, this treatment protects against:

- the acids of food products;
- washing with acids and alkalis with PH from 2 to 12;
- high-pressure washing;
- aggressive chemical solutions.



#### TEST CARRIED OUT AND DETERGENTS SUPPLIED BY ECOLAB





Immersion corrosion tests have been carried out using the most representative detergents and sanitisers in the industrial cleaning market.

TEST PROCEDURE PERFORMED:

Immersion test: Complete immersion in the test fluid.

Duration: 28 days, which simulates a product used for 7 years.

Example of washing cycle

<b>PHASE 1</b>		Pre-washing
<b>PHASE 2</b>		Washing with foam - 15 min.
<b>PHASE 3</b>		High-pressure washing
<b>PHASE 4</b>		Disinfection

#### Assessment

No decoration change (colour, degree and shine), no changes in protective properties according to DIN EN ISO 4628-1.

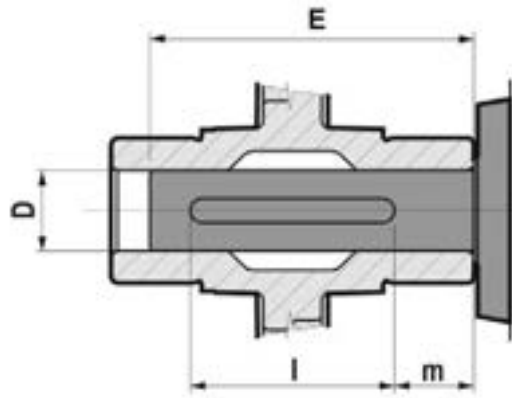

	D H8/h6	E*	l*	m*
<b>025</b>	11 (H8/g6)	45	30	7,5
<b>030</b>	14	55	40	7,5
<b>040</b>	18	70	50	10
	19			
<b>050</b>	24	80	55	12,5
	25			
<b>063</b>	25	100	70	15
	28			
<b>075</b>	28	105	75	15
	30			
	32			
<b>090</b>	35	120	80	20
	38			
	40			
<b>105</b>	42	135	95	20
<b>110</b>	42	135	95	20
<b>130</b>	45	145	100	22,5
<b>150</b>	50	175	130	22,5

(\*) Suggested values.

## 0,09 kW

n2 [rpm]	M2 [Nm]	fs	i	Gear reducer	Motor		Fr2 [N]
					Size	Pole	
250,0	3	3,7	5,00	NMRV025	56B	4	439
167,0	4	2,5	7,50	NMRV025	56B	4	503
125,0	6	2,1	10,00	NMRV025	56B	4	553
125,0	6	3,3	10,00	NMRV030	56B	4	752
115,0	6	3,4	7,50	NMRV030	63A	6	792
86,0	8	2,6	10,00	NMRV030	63A	6	871
83,0	8	1,5	15,00	NMRV025	56B	4	633
83,0	8	2,4	15,00	NMRV030	56B	4	861
63,0	10	1,2	20,00	NMRV025	56B	4	697
63,0	10	1,8	20,00	NMRV030	56B	4	948
57,0	11	1,9	15,00	NMRV030	63A	6	997
50,0	12	1,9	25,00	NMRV030	56B	4	1021
43,0	14	1,4	20,00	NMRV030	63A	6	1098
43,0	15	3,2	20,00	NMRV040	63A	6	2113
42,0	14	0,9	30,00	NMRV025	56B	4	798
42,0	14	1,5	30,00	NMRV030	56B	4	1085
39,0	17	3,8	22,08	HA31+NMRV040	63A	6	2217
36,0	19	3,6	23,75	HA31+NMRV040	63A	6	2272
34,0	21	3,3	25,50	HA31+NMRV040	63A	6	2326
34,0	21	4,0	25,50	HA31+NMRV050	63A	6	3193
34,0	16	1,5	25,00	NMRV030	63A	6	1183
34,0	18	2,5	25,00	NMRV040	63A	6	2276
31,0	17	0,8	40,00	NMRV025	56B	4	878
31,0	17	1,2	40,00	NMRV030	56B	4	1194
29,0	22	3,0	29,44	HA31+NMRV040	63A	6	2440
29,0	19	1,2	30,00	NMRV030	63A	6	1257
29,0	20	2,6	30,00	NMRV040	63A	6	2419
27,0	25	2,7	31,50	HA31+NMRV040	63A	6	2496
27,0	25	3,2	31,50	HA31+NMRV050	63A	6	3426
25,0	19	0,9	50,00	NMRV030	56B	4	1286
25,0	22	1,9	50,00	NMRV040	56B	4	2475
24,0	28	2,6	35,63	HA31+NMRV040	63A	6	2600
22,0	22	0,9	40,00	NMRV030	63A	6	1383
22,0	25	2,0	40,00	NMRV040	63A	6	2662
22,0	26	3,4	40,00	NMRV050	63A	6	3654
21,0	32	2,3	40,91	HA31+NMRV040	63A	6	2723
21,0	32	3,7	40,91	HA31+NMRV050	63A	6	3738
21,0	21	0,7	60,00	NMRV030	56B	4	1367
21,0	24	1,6	60,00	NMRV040	56B	4	2630
19,0	32	2,1	44,17	HA31+NMRV040	63A	6	2794
19,0	32	4,0	44,17	HA31+NMRV050	63A	6	3834
18,0	35	2,0	47,50	HA31+NMRV040	63A	6	2862

## 0,09 kW

n2 [rpm]	M2 [Nm]	fs	i	Gear reducer	Size	Motor Pole	Fr2 [N]
18,0	36	3,8	47,50	HA31+NMRV050	63A	6	3928
17,0	26	0,7	50,00	NMRV030	63A	6	1490
17,0	29	1,6	50,00	NMRV040	63A	6	2868
17,0	30	2,7	50,00	NMRV050	63A	6	3936
16,0	41	1,7	54,55	HA31+NMRV040	63A	6	2997
16,0	42	3,3	54,55	HA31+NMRV050	63A	6	4114
16,0	29	1,1	80,00	NMRV040	56B	4	2895
15,0	40	1,5	58,89	HA31+NMRV040	63A	6	3075
15,0	40	2,8	58,89	HA31+NMRV050	63A	6	4220
14,0	47	1,5	63,00	HA31+NMRV040	63A	6	3145
14,0	48	2,8	63,00	HA31+NMRV050	63A	6	4316
14,0	33	1,2	60,00	NMRV040	63A	6	3047
14,0	34	2,3	60,00	NMRV050	63A	6	4183
13,0	33	0,9	100,00	NMRV040	56B	4	3118
12,5	40	3,7	100,00	NMRV-P030/063	56B	4	4967
12,5	38	0,8	100,00	NMRV025/030	56B	4	1439
12,5	39	1,8	100,00	NMRV025/040	56B	4	2769
12,5	39	1,8	100,00	NMRV030/040	56B	4	2769
12,5	40	3,4	100,00	NMRV030/050	56B	4	3800
12,0	50	1,4	71,25	HA31+NMRV040	63A	6	3276
12,0	50	2,7	71,25	HA31+NMRV050	63A	6	4497
11,0	59	1,2	78,75	HA31+NMRV040	63A	6	3387
11,0	60	2,3	78,75	HA31+NMRV050	63A	6	4649
11,0	39	0,9	80,00	NMRV040	63A	6	3354
11,0	40	1,7	80,00	NMRV050	63A	6	4604
10,0	52	1,3	88,33	HA31+NMRV040	63A	6	3490
10,0	53	2,5	88,33	HA31+NMRV050	63A	6	4831
9,0	67	1,1	94,50	HA31+NMRV040	63A	6	3490
9,0	67	2,0	94,50	HA31+NMRV050	63A	6	4840
9,0	44	0,7	100,00	NMRV040	63A	6	3490
9,0	45	1,2	100,00	NMRV050	63A	6	4840
8,3	56	3,7	150,00	NMRV-P030/063	56B	4	5686
8,3	53	1,2	150,00	NMRV025/040	56B	4	3488
8,3	55	1,3	150,00	NMRV030/040	56B	4	3169
8,3	55	2,4	150,00	NMRV030/050	56B	4	4350
8,0	68	1,0	102,00	HA31+NMRV040	63A	6	3490
8,0	73	0,9	109,09	HA31+NMRV040	63A	6	3490
8,0	68	1,8	102,00	HA31+NMRV050	63A	6	4840
8,0	73	1,6	109,09	HA31+NMRV050	63A	6	4840
8,0	73	3,8	109,09	HW030+NMRV-P063	63A	6	6270
7,0	80	0,8	127,50	HA31+NMRV040	63A	6	3490
7,0	84	0,9	118,13	HA31+NMRV040	63A	6	3490



## 0,09 kW

n2 [rpm]	M2 [Nm]	fs	i	Gear reducer	Size	Motor Pole	Fr2 [N]
7,0	80	1,4	127,50	HA31+NMRV050	63A	6	4840
7,0	84	1,6	118,13	HA31+NMRV050	63A	6	4840
7,0	58	3,4	176,67	HW030+NMRV-P063	56B	4	6270
7,0	83	3,1	118,13	HW030+NMRV-P063	63A	6	6270
6,2	70	3,5	200,00	NMRV-P030/063	56B	4	6259
6,2	69	0,9	200,00	NMRV025/040	56B	4	3488
6,2	69	0,9	200,00	NMRV030/040	56B	4	3488
6,2	69	1,7	200,00	NMRV030/050	56B	4	4788
6,0	80	0,8	154,67	HA31+NMRV040	63A	6	3490
6,0	82	0,9	142,50	HA31+NMRV040	63A	6	3490
6,0	82	1,5	154,67	HA31+NMRV050	63A	6	4840
6,0	83	1,7	142,50	HA31+NMRV050	63A	6	4840
6,0	84	3,5	142,50	HW030+NMRV-P063	63A	6	6270
6,0	88	2,8	136,36	HW030+NMRV-P063	63A	6	6270
6,0	79	3,4	218,18	HW030+NMRV-P063	56B	4	6270
6,0	85	3,0	196,88	HW030+NMRV-P063	56B	4	6270
5,0	94	0,8	163,64	HA31+NMRV040	63A	6	3490
5,0	95	1,5	163,64	HA31+NMRV050	63A	6	4840
5,0	96	3,2	163,64	HW030+NMRV-P063	63A	6	6270
5,0	105	2,8	157,50	HW030+NMRV-P063	63A	6	6270
5,0	93	3,7	236,25	HW030+NMRV-P063	56B	4	6270
5,0	84	2,7	250,00	NMRV-P030/063	56B	4	6270
5,0	82	0,7	250,00	NMRV025/040	56B	4	3490
5,0	82	0,7	250,00	NMRV030/040	56B	4	3490
5,0	82	1,3	250,00	NMRV030/050	56B	4	4840
4,9	86	2,4	176,67	HW030+NMRV-P063	63A	6	6270
4,9	91	3,8	176,67	HW030+NMRV-P075	63A	6	7380
4,6	110	1,3	189,00	HA31+NMRV050	63A	6	4840
4,6	93	2,6	272,73	HW030+NMRV-P063	56B	4	6270
4,4	125	2,1	196,88	HW030+NMRV-P063	63A	6	6270
4,4	129	3,1	196,88	HW030+NMRV-P075	63A	6	7380
4,2	107	1,2	204,00	HA31+NMRV050	63A	6	4840
4,2	87	2,9	300,00	NMRV-P030/063	56B	4	6270
4,2	89	0,8	300,00	NMRV025/040	56B	4	3490
4,2	89	0,8	300,00	NMRV030/040	56B	4	3490
4,2	91	1,6	300,00	NMRV030/050	56B	4	4840
4,0	113	2,5	315,00	HW030+NMRV-P063	56B	4	6270
4,0	120	3,9	315,00	HW030+NMRV-P075	56B	4	7380
3,9	117	2,3	218,18	HW030+NMRV-P063	63A	6	6270
3,9	124	3,6	218,18	HW030+NMRV-P075	63A	6	7380
3,6	137	1,1	236,25	HA31+NMRV050	63A	6	4840
3,6	136	2,5	236,25	HW030+NMRV-P063	63A	6	6270

## 0,09 kW

n2 [rpm]	M2 [Nm]	fs	i	Gear reducer	Size	Motor Pole	Fr2 [N]
3,6	143	3,1	236,25	HW030+NMRV-P075	63A	6	7380
3,4	132	0,9	252,00	HA31+NMRV050	63A	6	4840
3,2	132	0,9	272,73	HA31+NMRV050	63A	6	4840
3,2	136	1,8	272,73	HW030+NMRV-P063	63A	6	6270
3,2	132	1,9	393,75	HW030+NMRV-P063	56B	4	6270
3,2	141	2,9	272,73	HW030+NMRV-P075	63A	6	7380
3,2	135	3,0	393,75	HW030+NMRV-P075	56B	4	7380
3,1	113	2,2	400,00	NMRV-P030/063	56B	4	6270
3,1	109	1,1	400,00	NMRV030/050	56B	4	4840
3,0	127	0,8	285,00	HA31+NMRV050	63A	6	4840
2,9	153	1,7	433,33	HW030+NMRV-P063	56B	4	6270
2,8	168	3,8	304,55	HW040+NMRV-P090	63A	6	8180
2,7	153	0,8	315,00	HA31+NMRV050	63A	6	4840
2,7	166	1,7	315,00	HW030+NMRV-P063	63A	6	6270
2,7	176	2,7	315,00	HW030+NMRV-P075	63A	6	7380
2,6	144	1,6	472,50	HW030+NMRV-P063	56B	4	6270
2,6	153	2,5	472,50	HW030+NMRV-P075	56B	4	7380
2,6	170	3,3	330,00	HW040+NMRV-P090	63A	6	8180
2,5	131	1,8	500,00	NMRV-P030/063	56B	4	6270
2,5	126	0,9	500,00	NMRV030/050	56B	4	4840
2,5	151	0,9	500,00	NMRV040/050	56B	4	3800
2,3	179	1,4	541,67	HW030+NMRV-P063	56B	4	6270
2,3	185	1,7	541,67	HW030+NMRV-P075	56B	4	7380
2,2	193	1,3	393,75	HW030+NMRV-P063	63A	6	6270
2,2	200	2,1	393,75	HW030+NMRV-P075	63A	6	7380
2,2	209	3,2	383,33	HW040+NMRV-P090	63A	6	8180
2,1	164	1,6	600,00	NMRV-P030/063	56B	4	6270
2,1	162	0,9	600,00	NMRV030/050	56B	4	4840
2,0	225	1,2	433,33	HW030+NMRV-P063	63A	6	6270
2,0	238	2,8	437,50	HW040+NMRV-P090	63A	6	8180
2,0	223	3,7	440,00	HW040+NMRV-P110	63A	6	10320
1,9	196	1,2	650,00	HW030+NMRV-P063	56B	4	6270
1,9	209	1,7	650,00	HW030+NMRV-P075	56B	4	7380
1,9	233	2,5	460,00	HW040+NMRV-P090	63A	6	8180
1,8	212	1,1	472,50	HW030+NMRV-P063	63A	6	6270
1,8	226	1,7	472,50	HW030+NMRV-P075	63A	6	7380
1,7	192	1,4	750,00	NMRV-P030/063	56B	4	6270
1,7	189	0,8	750,00	NMRV030/050	56B	4	4840
1,6	183	0,8	787,50	HW030+NMRV-P063	56B	4	6270
1,6	263	1,0	541,67	HW030+NMRV-P063	63A	6	6270
1,6	199	1,2	787,50	HW030+NMRV-P075	56B	4	7380
1,6	271	1,2	541,67	HW030+NMRV-P075	63A	6	7380

## 0,09 kW

n2 [rpm]	M2 [Nm]	fs	i	Gear reducer	Size	Motor Pole	Fr2 [N]
1,6	265	2,2	525,00	HW040+NMRV-P090	63A	6	8180
1,6	285	3,3	525,00	HW040+NMRV-P110	63A	6	10320
1,4	226	0,8	866,67	HW030+NMRV-P063	56B	4	6270
1,4	246	1,2	866,67	HW030+NMRV-P075	56B	4	7380
1,4	283	1,6	613,33	HW040+NMRV-P090	63A	6	8180
1,4	307	2,8	613,33	HW040+NMRV-P110	63A	6	10320
1,4	220	1,2	900,00	NMRV-P030/063	56B	4	6270
1,3	288	0,8	650,00	HW030+NMRV-P063	63A	6	6270
1,3	307	1,2	650,00	HW030+NMRV-P075	63A	6	7380
1,2	269	0,9	1083,33	HW030+NMRV-P075	56B	4	7380
1,2	322	1,4	700,00	HW040+NMRV-P090	63A	6	8180
1,2	349	2,5	700,00	HW040+NMRV-P110	63A	6	10320
1,1	292	0,8	787,50	HW030+NMRV-P075	63A	6	7380
1,1	315	1,2	766,67	HW040+NMRV-P090	63A	6	8180
1,1	344	1,9	766,67	HW040+NMRV-P110	63A	6	10320
1,0	267	1,0	1200,00	NMRV-P030/063	56B	4	6270
1,0	362	0,8	866,67	HW030+NMRV-P075	63A	6	7380
1,0	357	1,0	875,00	HW040+NMRV-P090	63A	6	8180
1,0	391	1,7	875,00	HW040+NMRV-P110	63A	6	10320
0,8	312	0,9	1500,00	NMRV-P030/063	56B	4	6270
0,8	350	0,8	1500,00	NMRV-P040/063	56B	4	6270
0,8	367	1,2	1500,00	NMRV-P040/075	56B	4	7380
0,8	385	1,8	1500,00	NMRV-P040/090	56B	4	8180
0,7	347	0,8	1800,00	NMRV-P030/063	56B	4	6270
0,7	412	1,1	1800,00	NMRV-P040/075	56B	4	7380
0,7	432	1,6	1800,00	NMRV-P040/090	56B	4	8180
0,5	507	0,8	2400,00	NMRV-P040/075	56B	4	7380
0,5	533	1,1	2400,00	NMRV-P040/090	56B	4	8180
0,4	623	0,9	3000,00	NMRV-P040/090	56B	4	8180
0,3	747	0,7	4000,00	NMRV-P040/090	56B	4	8180

## 0,12 kW

n2 [rpm]	M2 [Nm]	fs	i	Gear reducer	Size	Motor Pole	Fr2 [N]
351,7	3	2,8	7,50	NMRV025	56B	2	399
264,0	4	2,4	10,00	NMRV025	56B	2	439
264,0	4	3,5	10,00	NMRV030	56B	2	597
180,3	5	3,5	7,50	NMRV030	63A	4	683
176,3	5	1,7	15,00	NMRV025	56B	2	503
176,3	5	2,4	15,00	NMRV030	56B	2	683
174,0	6	3,7	5,00	NMRV030	63B	6	692
135,0	7	2,7	10,00	NMRV030	63A	4	752

## 0,12 kW

n2 [rpm]	M2 [Nm]	fs	i	Gear reducer	Motor Size	Pole	Fr2 [N]
132,5	7	1,3	20,00	NMRV025	56B	2	553
132,5	7	1,8	20,00	NMRV030	56B	2	752
116,3	8	2,5	7,50	NMRV030	63B	6	792
105,6	8	2,0	25,00	NMRV030	56B	2	810
89,7	10	1,9	15,00	NMRV030	63A	4	861
87,7	9	1,0	30,00	NMRV025	56B	2	633
87,7	9	1,6	30,00	NMRV030	56B	2	861
87,0	11	1,9	10,00	NMRV030	63B	6	871
67,5	13	1,4	20,00	NMRV030	63A	4	948
67,5	14	3,2	20,00	NMRV040	63A	4	1824
65,8	12	0,8	40,00	NMRV025	56B	2	697
65,8	12	1,2	40,00	NMRV030	56B	2	948
61,5	15	3,8	22,08	HA31+NMRV040	63A	4	1913
57,7	15	1,4	15,00	NMRV030	63B	6	997
57,7	16	3,2	15,00	NMRV040	63B	6	1920
56,4	17	3,8	23,75	HA31+NMRV040	63A	4	1959
54,4	15	1,5	25,00	NMRV030	63A	4	1021
54,4	16	2,4	25,00	NMRV040	63A	4	1964
53,4	18	3,6	25,50	HA31+NMRV040	63A	4	2006
52,8	14	1,0	50,00	NMRV030	56B	2	1021
52,8	15	2,0	50,00	NMRV040	56B	2	1964
46,3	20	3,0	29,44	HA31+NMRV040	63A	4	2105
45,3	17	1,2	30,00	NMRV030	63A	4	1085
45,3	18	2,6	30,00	NMRV040	63A	4	2087
43,8	15	0,8	60,00	NMRV030	56B	2	1085
43,8	17	1,6	60,00	NMRV040	56B	2	2087
43,5	19	1,1	20,00	NMRV030	63B	6	1098
43,5	20	2,4	20,00	NMRV040	63B	6	2113
43,3	22	3,1	31,50	HA31+NMRV040	63A	4	2153
43,3	22	3,4	31,50	HA31+NMRV050	63A	4	2955
39,5	23	2,9	22,08	HA31+NMRV040	63B	6	2217
38,3	24	2,8	35,63	HA31+NMRV040	63A	4	2243
36,4	25	2,7	23,75	HA31+NMRV040	63B	6	2272
36,4	25	3,1	23,75	HA31+NMRV050	63B	6	3118
34,4	27	2,5	25,50	HA31+NMRV040	63B	6	2326
34,4	27	3,0	25,50	HA31+NMRV050	63B	6	3193
34,4	22	1,1	25,00	NMRV030	63B	6	1183
34,4	24	1,9	25,00	NMRV040	63B	6	2276
34,3	21	0,9	40,00	NMRV030	63A	4	1194
34,3	23	2,0	40,00	NMRV040	63A	4	2298
34,3	23	3,5	40,00	NMRV050	63A	4	3153
33,2	27	2,5	40,91	HA31+NMRV040	63A	4	2349

## 0,12 kW

n2 [rpm]	M2 [Nm]	fs	i	Gear reducer	Size	Motor Pole	Fr2 [N]
33,2	28	4,0	40,91	HA31+NMRV050	63A	4	3224
32,9	21	1,2	80,00	NMRV040	56B	2	2298
30,2	28	2,2	44,17	HA31+NMRV040	63A	4	2410
29,3	30	2,2	29,44	HA31+NMRV040	63B	6	2440
29,3	25	0,9	30,00	NMRV030	63B	6	1257
29,3	27	2,0	30,00	NMRV040	63B	6	2419
28,2	31	2,2	47,50	HA31+NMRV040	63A	4	2469
27,3	34	2,0	31,50	HA31+NMRV040	63B	6	2496
27,3	34	2,4	31,50	HA31+NMRV050	63B	6	3426
27,2	24	0,8	50,00	NMRV030	63A	4	1286
27,2	27	1,6	50,00	NMRV040	63A	4	2475
27,2	27	2,8	50,00	NMRV050	63A	4	3397
26,9	24	1,0	100,00	NMRV040	56B	2	2475
25,2	35	2,0	54,55	HA31+NMRV040	63A	4	2585
25,2	36	3,7	54,55	HA31+NMRV050	63A	4	3548
24,3	37	2,0	35,63	HA31+NMRV040	63B	6	2600
24,3	37	3,1	35,63	HA31+NMRV050	63B	6	3569
23,2	36	1,6	58,89	HA31+NMRV040	63A	4	2652
23,2	36	2,8	58,89	HA31+NMRV050	63A	4	3640
22,3	30	0,7	40,00	NMRV030	63B	6	1383
22,3	34	1,5	40,00	NMRV040	63B	6	2662
22,3	34	2,6	40,00	NMRV050	63B	6	3654
22,2	30	1,3	60,00	NMRV040	63A	4	2630
22,2	31	2,3	60,00	NMRV050	63A	4	3610
21,2	42	1,7	40,91	HA31+NMRV040	63B	6	2723
21,2	43	2,8	40,91	HA31+NMRV050	63B	6	3738
21,2	40	1,7	63,00	HA31+NMRV040	63A	4	2712
21,2	41	3,3	63,00	HA31+NMRV050	63A	4	3723
19,2	42	1,6	44,17	HA31+NMRV040	63B	6	2794
19,2	42	3,0	44,17	HA31+NMRV050	63B	6	3834
19,1	44	1,6	71,25	HA31+NMRV040	63A	4	2826
19,1	44	2,9	71,25	HA31+NMRV050	63A	4	3879
18,2	46	1,5	47,50	HA31+NMRV040	63B	6	2862
18,2	48	2,8	47,50	HA31+NMRV050	63B	6	3928
17,2	39	1,2	50,00	NMRV040	63B	6	2868
17,2	40	2,0	50,00	NMRV050	63B	6	3936
17,1	50	1,4	78,75	HA31+NMRV040	63A	4	2922
17,1	52	2,6	78,75	HA31+NMRV050	63A	4	4010
17,1	36	0,9	80,00	NMRV040	63A	4	2895
17,1	37	1,8	80,00	NMRV050	63A	4	3973
16,2	53	1,3	54,55	HA31+NMRV040	63B	6	2997
16,2	55	2,5	54,55	HA31+NMRV050	63B	6	4114

## 0,12 kW

n2 [rpm]	M2 [Nm]	fs	i	Gear reducer	Size	Motor Pole	Fr2 [N]
15,2	53	1,2	58,89	HA31+NMRV040	63B	6	3075
15,2	53	2,1	58,89	HA31+NMRV050	63B	6	4220
15,1	47	1,3	88,33	HA31+NMRV040	63A	4	3036
15,1	47	2,4	88,33	HA31+NMRV050	63A	4	4167
14,2	62	1,1	63,00	HA31+NMRV040	63B	6	3145
14,2	63	2,1	63,00	HA31+NMRV050	63B	6	4316
14,2	43	0,9	60,00	NMRV040	63B	6	3047
14,2	44	1,7	60,00	NMRV050	63B	6	4183
14,1	57	1,2	94,50	HA31+NMRV040	63A	4	3105
14,1	57	2,3	94,50	HA31+NMRV050	63A	4	4262
13,5	54	2,8	100,00	NMRV-P030/063	63A	4	4967
13,5	52	1,4	100,00	NMRV030/040	63A	4	2769
13,5	54	2,6	100,00	NMRV030/050	63A	4	3800
13,5	55	2,5	100,00	NMRV040/050	63A	4	3800
13,1	59	1,1	102,00	HA31+NMRV040	63A	4	3185
13,1	59	1,9	102,00	HA31+NMRV050	63A	4	4372
13,1	41	0,7	100,00	NMRV040	63A	4	3118
13,1	43	1,3	100,00	NMRV050	63A	4	4280
12,1	66	1,1	71,25	HA31+NMRV040	63B	6	3276
12,1	66	2,0	71,25	HA31+NMRV050	63B	6	4497
12,1	63	1,0	109,09	HA31+NMRV040	63A	4	3257
12,1	63	1,8	109,09	HA31+NMRV050	63A	4	4471
12,1	64	3,9	109,09	HW030+NMRV-P063	63A	4	5844
11,1	77	0,9	78,75	HA31+NMRV040	63B	6	3387
11,1	79	1,7	78,75	HA31+NMRV050	63B	6	4649
11,1	70	3,6	77,33	HW030+NMRV-P063	63B	6	6041
11,1	77	3,7	81,82	HW030+NMRV-P063	63B	6	6155
11,1	52	1,3	80,00	NMRV050	63B	6	4604
11,1	69	0,8	127,50	HA31+NMRV040	63A	4	3431
11,1	71	1,0	118,13	HA31+NMRV040	63A	4	3345
11,1	69	1,5	127,50	HA31+NMRV050	63A	4	4709
11,1	71	1,9	118,13	HA31+NMRV050	63A	4	4591
11,1	71	3,6	118,13	HW030+NMRV-P063	63A	4	6001
10,1	68	1,0	88,33	HA31+NMRV040	63B	6	3490
10,1	70	1,9	88,33	HA31+NMRV050	63B	6	4831
10,1	71	3,5	88,33	HW030+NMRV-P063	63B	6	6270
10,1	76	3,0	136,36	HW030+NMRV-P063	63A	4	6270
9,1	88	0,8	94,50	HA31+NMRV040	63B	6	3490
9,1	88	1,5	94,50	HA31+NMRV050	63B	6	4840
9,1	85	3,1	95,00	HW030+NMRV-P063	63B	6	6270
9,1	59	0,9	100,00	NMRV050	63B	6	4840
9,1	71	0,8	154,67	HA31+NMRV040	63A	4	3490

## 0,12 kW

n2 [rpm]	M2 [Nm]	fs	i	Gear reducer	Size	Motor Pole	Fr2 [N]
9,1	71	1,0	142,50	HA31+NMRV040	63A	4	3490
9,1	72	1,5	154,67	HA31+NMRV050	63A	4	4840
9,1	72	1,9	142,50	HA31+NMRV050	63A	4	4840
9,1	73	3,4	142,50	HW030+NMRV-P063	63A	4	6270
9,1	90	3,0	157,50	HW030+NMRV-P063	63A	4	6270
9,0	74	2,8	150,00	NMRV-P030/063	63A	4	5686
9,0	76	3,4	150,00	NMRV-P040/063	63A	4	5686
9,0	73	1,0	150,00	NMRV030/040	63A	4	3169
9,0	73	1,8	150,00	NMRV030/050	63A	4	4350
9,0	75	1,8	150,00	NMRV040/050	63A	4	4350
8,1	90	0,7	102,00	HA31+NMRV040	63B	6	3490
8,1	90	1,3	102,00	HA31+NMRV050	63B	6	4840
8,1	96	1,2	109,09	HA31+NMRV050	63B	6	4840
8,1	97	2,8	109,09	HW030+NMRV-P063	63B	6	6270
8,1	80	0,9	163,64	HA31+NMRV040	63A	4	3490
8,1	82	1,7	163,64	HA31+NMRV050	63A	4	4840
8,1	77	2,3	176,67	HW030+NMRV-P063	63A	4	6270
8,1	83	3,1	163,64	HW030+NMRV-P063	63A	4	6270
8,1	82	3,7	176,67	HW030+NMRV-P075	63A	4	7380
7,1	106	1,0	127,50	HA31+NMRV050	63B	6	4840
7,1	110	1,2	118,13	HA31+NMRV050	63B	6	4840
7,1	110	2,4	118,13	HW030+NMRV-P063	63B	6	6270
7,1	92	0,8	189,00	HA31+NMRV040	63A	4	3490
7,1	93	1,3	204,00	HA31+NMRV050	63A	4	4840
7,1	94	1,5	189,00	HA31+NMRV050	63A	4	4840
7,1	108	2,3	196,88	HW030+NMRV-P063	63A	4	6270
7,1	111	3,5	196,88	HW030+NMRV-P075	63A	4	7380
6,8	94	2,7	200,00	NMRV-P030/063	63A	4	6259
6,8	96	2,6	200,00	NMRV-P040/063	63A	4	6259
6,8	93	1,3	200,00	NMRV030/050	63A	4	4788
6,8	95	1,2	200,00	NMRV040/050	63A	4	4788
6,1	108	1,1	154,67	HA31+NMRV050	63B	6	4840
6,1	110	1,3	142,50	HA31+NMRV050	63B	6	4840
6,1	111	2,6	142,50	HW030+NMRV-P063	63B	6	6270
6,1	116	2,1	136,36	HW030+NMRV-P063	63B	6	6270
6,1	118	3,6	154,67	HW030+NMRV-P075	63B	6	7380
6,1	117	4,0	142,50	HW030+NMRV-P075	63B	6	7380
6,1	120	3,5	136,36	HW030+NMRV-P075	63B	6	7380
6,0	117	1,2	236,25	HA31+NMRV050	63A	4	4840
6,0	102	2,4	218,18	HW030+NMRV-P063	63A	4	6270
6,0	118	2,4	236,25	HW030+NMRV-P063	63A	4	6270
6,0	107	3,8	218,18	HW030+NMRV-P075	63A	4	7380

## 0,12 kW

n2 [rpm]	M2 [Nm]	fs	i	Gear reducer	Size	Motor Pole	Fr2 [N]
6,0	124	3,8	236,25	HW030+NMRV-P075	63A	4	7380
5,4	113	2,0	250,00	NMRV-P030/063	63A	4	6270
5,4	116	2,0	250,00	NMRV-P040/063	63A	4	6270
5,4	119	3,2	250,00	NMRV-P040/075	63A	4	7380
5,4	109	1,0	250,00	NMRV030/050	63A	4	4840
5,4	112	1,0	250,00	NMRV040/050	63A	4	4840
5,1	126	1,1	163,64	HA31+NMRV050	63B	6	4840
5,1	127	2,4	163,64	HW030+NMRV-P063	63B	6	6270
5,1	138	2,1	157,50	HW030+NMRV-P063	63B	6	6270
5,1	132	3,7	163,64	HW030+NMRV-P075	63B	6	7380
5,0	113	1,1	252,00	HA31+NMRV050	63A	4	4840
5,0	113	1,8	176,67	HW030+NMRV-P063	63B	6	6270
5,0	120	2,9	176,67	HW030+NMRV-P075	63B	6	7380
4,9	115	1,0	272,73	HA31+NMRV050	63A	4	4840
4,9	119	1,9	272,73	HW030+NMRV-P063	63A	4	6270
4,9	124	3,0	272,73	HW030+NMRV-P075	63A	4	7380
4,7	112	0,9	285,00	HA31+NMRV050	63A	4	4840
4,7	145	1,0	189,00	HA31+NMRV050	63B	6	4840
4,7	132	3,8	186,32	HW040+NMRV-P090	63B	6	8180
4,5	116	2,2	300,00	NMRV-P030/063	63A	4	6270
4,5	126	2,1	300,00	NMRV-P040/063	63A	4	6270
4,5	133	3,3	300,00	NMRV-P040/075	63A	4	7380
4,5	121	1,2	300,00	NMRV030/050	63A	4	4840
4,5	124	1,2	300,00	NMRV040/050	63A	4	4840
4,5	165	1,6	196,88	HW030+NMRV-P063	63B	6	6270
4,5	170	2,4	196,88	HW030+NMRV-P075	63B	6	7380
4,4	147	3,7	304,55	HW040+NMRV-P090	63A	4	8180
4,3	131	0,9	315,00	HA31+NMRV050	63A	4	4840
4,3	144	1,8	315,00	HW030+NMRV-P063	63A	4	6270
4,3	152	2,9	315,00	HW030+NMRV-P075	63A	4	7380
4,2	140	0,9	204,00	HA31+NMRV050	63B	6	4840
4,1	150	3,5	330,00	HW040+NMRV-P090	63A	4	8180
3,9	154	1,7	218,18	HW030+NMRV-P063	63B	6	6270
3,9	163	2,7	218,18	HW030+NMRV-P075	63B	6	7380
3,6	181	0,8	236,25	HA31+NMRV050	63B	6	4840
3,6	180	1,9	236,25	HW030+NMRV-P063	63B	6	6270
3,6	189	2,4	236,25	HW030+NMRV-P075	63B	6	7380
3,5	182	3,4	383,33	HW040+NMRV-P090	63A	4	8180
3,4	174	0,7	252,00	HA31+NMRV050	63B	6	4840
3,4	175	3,0	252,00	HW040+NMRV-P090	63B	6	8180
3,4	168	1,4	393,75	HW030+NMRV-P063	63A	4	6270
3,4	174	2,3	393,75	HW030+NMRV-P075	63A	4	7380



## 0,12 kW

n2 [rpm]	M2 [Nm]	fs	i	Gear reducer	Size	Motor Pole	Fr2 [N]
3,4	151	1,7	400,00	NMRV-P030/063	63A	4	6270
3,4	155	1,6	400,00	NMRV-P040/063	63A	4	6270
3,4	163	2,5	400,00	NMRV-P040/075	63A	4	7380
3,4	172	3,5	400,00	NMRV-P040/090	63A	4	8180
3,4	146	0,8	400,00	NMRV030/050	63A	4	4840
3,4	149	0,8	400,00	NMRV040/050	63A	4	4840
3,2	179	1,4	272,73	HW030+NMRV-P063	63B	6	6270
3,2	186	2,1	272,73	HW030+NMRV-P075	63B	6	7380
3,1	202	3,1	275,00	HW040+NMRV-P090	63B	6	8180
3,1	195	1,4	433,33	HW030+NMRV-P063	63A	4	6270
3,1	206	3,1	437,50	HW040+NMRV-P090	63A	4	8180
3,0	196	4,0	440,00	HW040+NMRV-P110	63A	4	10320
2,9	203	2,7	460,00	HW040+NMRV-P090	63A	4	8180
2,8	221	2,9	304,55	HW040+NMRV-P090	63B	6	8180
2,8	185	1,2	472,50	HW030+NMRV-P063	63A	4	6270
2,8	197	1,9	472,50	HW030+NMRV-P075	63A	4	7380
2,7	218	1,3	315,00	HW030+NMRV-P063	63B	6	6270
2,7	231	2,0	315,00	HW030+NMRV-P075	63B	6	7380
2,7	176	1,3	500,00	NMRV-P030/063	63A	4	6270
2,7	215	1,1	500,00	NMRV-P040/063	63A	4	6270
2,7	187	2,0	500,00	NMRV-P040/075	63A	4	7380
2,7	201	2,8	500,00	NMRV-P040/090	63A	4	8180
2,7	169	0,7	500,00	NMRV030/050	63A	4	4840
2,6	224	2,5	330,00	HW040+NMRV-P090	63B	6	8180
2,6	230	2,4	525,00	HW040+NMRV-P090	63A	4	8180
2,6	247	3,7	525,00	HW040+NMRV-P110	63A	4	10320
2,5	226	1,1	541,67	HW030+NMRV-P063	63A	4	6270
2,5	234	1,6	541,67	HW030+NMRV-P075	63A	4	7380
2,2	220	1,2	600,00	NMRV-P030/063	63A	4	6270
2,2	235	1,1	600,00	NMRV-P040/063	63A	4	6270
2,2	246	1,8	600,00	NMRV-P040/075	63A	4	7380
2,2	258	2,7	600,00	NMRV-P040/090	63A	4	8180
2,2	254	1,0	393,75	HW030+NMRV-P063	63B	6	6270
2,2	263	1,6	393,75	HW030+NMRV-P075	63B	6	7380
2,2	276	2,4	383,33	HW040+NMRV-P090	63B	6	8180
2,2	297	3,4	383,33	HW040+NMRV-P110	63B	6	10320
2,2	246	1,8	613,33	HW040+NMRV-P090	63A	4	8180
2,2	266	3,0	613,33	HW040+NMRV-P110	63A	4	10320
2,1	249	0,9	650,00	HW030+NMRV-P063	63A	4	6270
2,1	265	1,4	650,00	HW030+NMRV-P075	63A	4	7380
2,0	298	0,9	433,33	HW030+NMRV-P063	63B	6	6270
2,0	313	2,1	437,50	HW040+NMRV-P090	63B	6	8180

## 0,12 kW

n2 [rpm]	M2 [Nm]	fs	i	Gear reducer	Size	Motor Pole	Fr2 [N]
2,0	295	2,8	440,00	HW040+NMRV-P110	63B	6	10320
1,9	307	1,8	460,00	HW040+NMRV-P090	63B	6	8180
1,9	331	3,1	460,00	HW040+NMRV-P110	63B	6	10320
1,9	279	1,6	700,00	HW040+NMRV-P090	63A	4	8180
1,9	302	2,7	700,00	HW040+NMRV-P110	63A	4	10320
1,8	280	0,8	472,50	HW030+NMRV-P063	63B	6	6270
1,8	298	1,3	472,50	HW030+NMRV-P075	63B	6	7380
1,8	256	1,0	750,00	NMRV-P030/063	63A	4	6270
1,8	283	1,0	750,00	NMRV-P040/063	63A	4	6270
1,8	297	1,5	750,00	NMRV-P040/075	63A	4	7380
1,8	311	2,2	750,00	NMRV-P040/090	63A	4	8180
1,7	256	0,9	787,50	HW030+NMRV-P075	63A	4	7380
1,7	276	1,3	766,67	HW040+NMRV-P090	63A	4	8180
1,7	301	2,1	766,67	HW040+NMRV-P110	63A	4	10320
1,6	346	0,7	541,67	HW030+NMRV-P063	63B	6	6270
1,6	358	0,9	541,67	HW030+NMRV-P075	63B	6	7380
1,6	349	1,6	525,00	HW040+NMRV-P090	63B	6	8180
1,6	376	2,4	525,00	HW040+NMRV-P110	63B	6	10320
1,5	313	0,9	866,67	HW030+NMRV-P075	63A	4	7380
1,5	312	1,1	875,00	HW040+NMRV-P090	63A	4	8180
1,5	340	1,9	875,00	HW040+NMRV-P110	63A	4	10320
1,5	295	0,9	900,00	NMRV-P030/063	63A	4	6270
1,5	317	0,8	900,00	NMRV-P040/063	63A	4	6270
1,5	333	1,3	900,00	NMRV-P040/075	63A	4	7380
1,5	347	2,0	900,00	NMRV-P040/090	63A	4	8180
1,4	374	1,2	613,33	HW040+NMRV-P090	63B	6	8180
1,4	404	2,1	613,33	HW040+NMRV-P110	63B	6	10320
1,3	404	0,9	650,00	HW030+NMRV-P075	63B	6	7380
1,2	424	1,1	700,00	HW040+NMRV-P090	63B	6	8180
1,2	460	1,8	700,00	HW040+NMRV-P110	63B	6	10320
1,1	357	0,8	1200,00	NMRV-P030/063	63A	4	6270
1,1	412	1,1	1200,00	NMRV-P040/075	63A	4	7380
1,1	431	1,6	1200,00	NMRV-P040/090	63A	4	8180
1,1	445	1,6	1200,00	NMRV-P050/090	63A	4	8180
1,1	445	2,8	1200,00	NMRV-P050/110	63A	4	10320
1,1	415	0,9	766,67	HW040+NMRV-P090	63B	6	8180
1,1	454	1,4	766,67	HW040+NMRV-P110	63B	6	10320
1,0	471	0,8	875,00	HW040+NMRV-P090	63B	6	8180
1,0	515	1,3	875,00	HW040+NMRV-P110	63B	6	10320
0,9	491	0,9	1500,00	NMRV-P040/075	63A	4	7380
0,9	514	1,4	1500,00	NMRV-P040/090	63A	4	8180
0,9	523	1,3	1500,00	NMRV-P050/090	63A	4	8180

## 0,12 kW

n2 [rpm]	M2 [Nm]	fs	i	Gear reducer	Motor		Fr2 [N]
					Size	Pole	
0,9	523	2,4	1500,00	NMRV-P050/110	63A	4	10320
0,7	552	0,8	1800,00	NMRV-P040/075	63A	4	7380
0,7	578	1,2	1800,00	NMRV-P040/090	63A	4	8180
0,7	588	1,2	1800,00	NMRV-P050/090	63A	4	8180
0,7	588	2,1	1800,00	NMRV-P050/110	63A	4	10320
0,6	714	0,8	2400,00	NMRV-P040/090	63A	4	8180
0,6	726	0,8	2400,00	NMRV-P050/090	63A	4	8180
0,6	760	1,5	2400,00	NMRV-P050/110	63A	4	10320
0,5	907	1,2	3000,00	NMRV-P050/110	63A	4	10320
0,3	1088	1,0	4000,00	NMRV-P050/110	63A	4	10320
0,3	1260	0,9	5000,00	NMRV-P050/110	63A	4	10320

## 0,18 kW

n2 [rpm]	M2 [Nm]	fs	i	Gear reducer	Motor		Fr2 [N]
					Size	Pole	
377,0	4	3,2	7,50	NMRV030	63A	2	542
283,0	5	2,5	10,00	NMRV030	63A	2	597
272,0	6	3,5	5,00	NMRV030	63B	4	597
189,0	8	1,7	15,00	NMRV030	63A	2	683
189,0	8	4,0	15,00	NMRV040	63A	2	1315
181,0	8	2,4	7,50	NMRV030	63B	4	683
141,5	10	1,2	20,00	NMRV030	63A	2	752
141,5	10	2,8	20,00	NMRV040	63A	2	1447
136,0	11	1,8	10,00	NMRV030	63B	4	752
120,0	12	3,8	7,50	NMRV040	71A	6	1524
113,2	12	1,4	25,00	NMRV030	63A	2	810
113,2	12	2,3	25,00	NMRV040	63A	2	1559
94,0	13	1,1	30,00	NMRV030	63A	2	861
94,0	14	2,4	30,00	NMRV040	63A	2	1657
91,0	15	1,3	15,00	NMRV030	63B	4	861
91,0	16	2,8	15,00	NMRV040	63B	4	1657
90,0	16	3,0	10,00	NMRV040	71A	6	1677
70,8	16	0,9	40,00	NMRV030	63A	2	948
70,8	18	1,7	40,00	NMRV040	63A	2	1824
70,8	18	3,2	40,00	NMRV050	63A	2	2503
68,5	19	0,9	20,00	NMRV030	63B	4	948
68,5	20	2,1	20,00	NMRV040	63B	4	1824
61,4	22	2,6	22,08	HA31+NMRV040	63B	4	1917
60,0	23	2,2	15,00	NMRV040	71A	6	1920
57,3	24	2,6	23,75	HA31+NMRV040	63B	4	1964
57,3	24	3,0	23,75	HA31+NMRV050	63B	4	2696
56,6	21	1,4	50,00	NMRV040	63A	2	1964

## 0,18 kW

n2 [rpm]	M2 [Nm]	fs	i	Gear reducer	Size	Motor Pole	Fr2 [N]
56,6	21	2,5	50,00	NMRV050	63A	2	2696
54,2	22	1,0	25,00	NMRV030	63B	4	1021
54,2	24	1,6	25,00	NMRV040	63B	4	1964
53,2	26	2,5	25,50	HA31+NMRV040	63B	4	2011
53,2	26	2,9	25,50	HA31+NMRV050	63B	4	2761
47,5	24	1,2	60,00	NMRV040	63A	2	2087
47,5	25	2,0	60,00	NMRV050	63A	2	2865
46,0	29	2,0	29,44	HA31+NMRV040	63B	4	2110
46,0	29	3,9	29,44	HA31+NMRV050	63B	4	2896
45,0	29	1,7	20,00	NMRV040	71A	6	2113
45,0	29	2,8	20,00	NMRV050	71A	6	2900
45,0	25	0,8	30,00	NMRV030	63B	4	1085
45,0	27	1,7	30,00	NMRV040	63B	4	2087
42,9	32	2,0	31,50	HA31+NMRV040	63B	4	2158
42,9	32	2,4	31,50	HA31+NMRV050	63B	4	2962
41,0	33	2,0	22,08	HA31+NMRV040	71A	6	2184
41,0	34	3,1	22,08	HA31+NMRV050	71A	6	2997
38,0	37	1,9	23,75	HA31+NMRV040	71A	6	2237
38,0	37	2,1	23,75	HA31+NMRV050	71A	6	3071
37,8	35	1,9	35,63	HA31+NMRV040	63B	4	2249
37,8	36	3,0	35,63	HA31+NMRV050	63B	4	3086
36,0	35	1,3	25,00	NMRV040	71A	6	2276
36,0	35	2,2	25,00	NMRV050	71A	6	3124
35,4	29	0,8	80,00	NMRV040	63A	2	2298
35,4	30	1,5	80,00	NMRV050	63A	2	3153
35,0	39	1,7	25,50	HA31+NMRV040	71A	6	2291
35,0	39	2,1	25,50	HA31+NMRV050	71A	6	3145
33,7	40	1,7	40,91	HA31+NMRV040	63B	4	2355
33,7	41	2,7	40,91	HA31+NMRV050	63B	4	3232
33,7	33	1,3	40,00	NMRV040	63B	4	2298
33,7	34	2,4	40,00	NMRV050	63B	4	3153
31,0	43	1,6	29,44	HA31+NMRV040	71A	6	2404
31,0	44	2,9	29,44	HA31+NMRV050	71A	6	3299
30,7	41	1,5	44,17	HA31+NMRV040	63B	4	2416
30,7	41	2,8	44,17	HA31+NMRV050	63B	4	3316
30,0	38	1,4	30,00	NMRV040	71A	6	2419
30,0	40	2,4	30,00	NMRV050	71A	6	3320
29,0	48	1,4	31,50	HA31+NMRV040	71A	6	2458
29,0	48	1,7	31,50	HA31+NMRV050	71A	6	3374
28,6	46	1,4	47,50	HA31+NMRV040	63B	4	2475
28,6	47	2,8	47,50	HA31+NMRV050	63B	4	3397
28,3	35	1,1	100,00	NMRV050	63A	2	3397

## 0,18 kW

n2 [rpm]	M2 [Nm]	fs	i	Gear reducer	Size	Motor Pole	Fr2 [N]
27,6	40	1,0	50,00	NMRV040	63B	4	2475
27,6	40	1,9	50,00	NMRV050	63B	4	3397
25,0	53	1,4	35,63	HA31+NMRV040	71A	6	2561
25,0	53	2,1	35,63	HA31+NMRV050	71A	6	3515
24,5	52	1,3	54,55	HA31+NMRV040	63B	4	2592
24,5	53	2,5	54,55	HA31+NMRV050	63B	4	3557
23,5	53	1,1	58,89	HA31+NMRV040	63B	4	2659
23,5	53	1,9	58,89	HA31+NMRV050	63B	4	3649
23,5	54	4,1	58,00	HW030+NMRV-P063	63B	4	4746
23,0	50	3,4	40,00	NMRV-P063	71A	6	4776
23,0	48	1,0	40,00	NMRV040	71A	6	2662
23,0	49	1,8	40,00	NMRV050	71A	6	3654
22,5	45	0,8	60,00	NMRV040	63B	4	2630
22,5	46	1,5	60,00	NMRV050	63B	4	3610
22,0	61	1,2	40,91	HA31+NMRV040	71A	6	2682
22,0	61	1,9	40,91	HA31+NMRV050	71A	6	3681
21,5	60	1,1	63,00	HA31+NMRV040	63B	4	2719
21,5	62	2,2	63,00	HA31+NMRV050	63B	4	3732
20,0	61	1,1	44,17	HA31+NMRV040	71A	6	2752
20,0	61	2,1	44,17	HA31+NMRV050	71A	6	3777
20,0	62	3,8	44,17	HW030+NMRV-P063	71A	6	4937
19,4	65	1,0	71,25	HA31+NMRV040	63B	4	2833
19,4	65	1,9	71,25	HA31+NMRV050	63B	4	3889
19,4	66	3,6	71,25	HW030+NMRV-P063	63B	4	5083
19,0	68	1,0	47,50	HA31+NMRV040	71A	6	2819
19,0	70	2,0	47,50	HA31+NMRV050	71A	6	3869
19,0	69	3,6	47,50	HW030+NMRV-P063	71A	6	5058
18,0	59	2,7	50,00	NMRV-P063	71A	6	5145
18,0	57	1,4	50,00	NMRV050	71A	6	3936
17,4	74	0,9	78,75	HA31+NMRV040	63B	4	2929
17,4	76	1,7	78,75	HA31+NMRV050	63B	4	4021
17,4	68	3,2	77,33	HW030+NMRV-P063	63B	4	5224
17,4	55	1,2	80,00	NMRV050	63B	4	3973
17,0	78	0,9	54,55	HA31+NMRV040	71A	6	2952
17,0	80	1,7	54,55	HA31+NMRV050	71A	6	4052
16,4	75	3,3	81,82	HW030+NMRV-P063	63B	4	5323
16,0	80	3,2	58,00	HW030+NMRV-P063	71A	6	5406
16,0	82	3,5	58,00	HW030+NMRV-P075	71A	6	6381
15,3	68	0,9	88,33	HA31+NMRV040	63B	4	3044
15,3	70	1,6	88,33	HA31+NMRV050	63B	4	4177
15,3	71	3,1	88,33	HW030+NMRV-P063	63B	4	5460
15,0	77	0,8	58,89	HA31+NMRV040	71A	6	3028

## 0,18 kW

n2 [rpm]	M2 [Nm]	fs	i	Gear reducer	Size	Motor Pole	Fr2 [N]
15,0	77	1,5	58,89	HA31+NMRV050	71A	6	4157
15,0	68	2,3	60,00	NMRV-P063	71A	6	5467
15,0	71	3,5	60,00	NMRV-P075	71A	6	6453
15,0	64	1,2	60,00	NMRV050	71A	6	4183
14,3	85	0,8	94,50	HA31+NMRV040	63B	4	3113
14,3	85	1,5	94,50	HA31+NMRV050	63B	4	4272
14,3	83	2,9	95,00	HW030+NMRV-P063	63B	4	5595
14,0	90	0,8	63,00	HA31+NMRV040	71A	6	3097
14,0	92	1,5	63,00	HA31+NMRV050	71A	6	4251
13,6	79	1,9	100,00	NMRV-P030/063	63B	4	4967
13,6	80	3,2	100,00	NMRV-P040/063	63B	4	4967
13,6	76	0,9	100,00	NMRV030/040	63B	4	2769
13,6	79	1,7	100,00	NMRV030/050	63B	4	3800
13,6	80	1,7	100,00	NMRV040/050	63B	4	3800
13,3	88	0,7	102,00	HA31+NMRV040	63B	4	3193
13,3	88	1,3	102,00	HA31+NMRV050	63B	4	4383
13,3	64	0,9	100,00	NMRV050	63B	4	4280
13,0	96	0,7	71,25	HA31+NMRV040	71A	6	3227
13,0	96	1,4	71,25	HA31+NMRV050	71A	6	4429
13,0	97	2,8	71,25	HW030+NMRV-P063	71A	6	5790
13,0	100	3,1	71,25	HW030+NMRV-P075	71A	6	6834
12,3	94	1,2	109,09	HA31+NMRV050	63B	4	4482
12,3	95	2,7	109,09	HW030+NMRV-P063	63B	4	5858
12,0	101	2,5	77,33	HW030+NMRV-P063	71A	6	5950
11,2	106	1,2	118,13	HA31+NMRV050	63B	4	4602
11,2	107	2,5	118,13	HW030+NMRV-P063	63B	4	6016
11,2	95	4,0	116,00	HW030+NMRV-P075	63B	4	7058
11,0	115	1,2	78,75	HA31+NMRV050	71A	6	4579
11,0	111	2,6	81,82	HW030+NMRV-P063	71A	6	6063
11,0	114	2,8	81,82	HW030+NMRV-P075	71A	6	7156
11,0	81	1,7	80,00	NMRV-P063	71A	6	6018
11,0	86	2,6	80,00	NMRV-P075	71A	6	7103
11,0	76	0,9	80,00	NMRV050	71A	6	4604
10,2	104	1,0	127,50	HA31+NMRV050	63B	4	4721
10,2	113	2,0	136,36	HW030+NMRV-P063	63B	4	6270
10,2	117	3,0	136,36	HW030+NMRV-P075	63B	4	7380
10,0	101	1,3	88,33	HA31+NMRV050	71A	6	4758
10,0	128	1,1	94,50	HA31+NMRV050	71A	6	4840
10,0	103	2,4	88,33	HW030+NMRV-P063	71A	6	6220
10,0	108	3,7	88,33	HW030+NMRV-P075	71A	6	7341
9,2	109	1,0	154,67	HA31+NMRV050	63B	4	4840
9,2	108	1,2	142,50	HA31+NMRV050	63B	4	4840

## 0,18 kW

n2 [rpm]	M2 [Nm]	fs	i	Gear reducer	Size	Motor Pole	Fr2 [N]
9,2	110	2,4	142,50	HW030+NMRV-P063	63B	4	6270
9,2	117	3,2	154,67	HW030+NMRV-P075	63B	4	7380
9,2	114	3,5	142,50	HW030+NMRV-P075	63B	4	7380
9,1	111	1,9	150,00	NMRV-P030/063	63B	4	5686
9,1	113	2,2	150,00	NMRV-P040/063	63B	4	5686
9,1	116	3,7	150,00	NMRV-P040/075	63B	4	6712
9,1	110	1,2	150,00	NMRV030/050	63B	4	4350
9,1	111	1,2	150,00	NMRV040/050	63B	4	4350
9,0	130	0,9	102,00	HA31+NMRV050	71A	6	4840
9,0	123	2,2	95,00	HW030+NMRV-P063	71A	6	6270
9,0	126	3,6	95,00	HW030+NMRV-P075	71A	6	7380
9,0	92	1,4	100,00	NMRV-P063	71A	6	6270
9,0	97	2,0	100,00	NMRV-P075	71A	6	7380
8,2	122	1,1	163,64	HA31+NMRV050	63B	4	4840
8,2	116	1,5	176,67	HW030+NMRV-P063	63B	4	6270
8,2	124	2,1	163,64	HW030+NMRV-P063	63B	4	6270
8,2	134	2,0	157,50	HW030+NMRV-P063	63B	4	6270
8,2	122	2,6	176,67	HW030+NMRV-P075	63B	4	7380
8,2	130	3,3	163,64	HW030+NMRV-P075	63B	4	7380
8,0	139	0,9	109,09	HA31+NMRV050	71A	6	4840
8,0	160	0,8	118,13	HA31+NMRV050	71A	6	4840
8,0	140	2,0	109,09	HW030+NMRV-P063	71A	6	6270
8,0	159	1,6	118,13	HW030+NMRV-P063	71A	6	6270
8,0	139	3,2	116,00	HW030+NMRV-P075	71A	6	7380
8,0	144	3,3	109,09	HW030+NMRV-P075	71A	6	7380
7,2	139	0,8	204,00	HA31+NMRV050	63B	4	4840
7,2	140	1,0	189,00	HA31+NMRV050	63B	4	4840
7,2	160	1,5	196,88	HW030+NMRV-P063	63B	4	6270
7,2	165	2,4	196,88	HW030+NMRV-P075	63B	4	7380
7,2	135	3,4	186,32	HW040+NMRV-P090	63B	4	8180
7,0	154	0,7	127,50	HA31+NMRV050	71A	6	4840
7,0	168	1,5	136,36	HW030+NMRV-P063	71A	6	6270
7,0	173	2,4	136,36	HW030+NMRV-P075	71A	6	7380
7,0	182	3,8	137,50	HW040+NMRV-P090	71A	6	8180
6,8	140	1,8	200,00	NMRV-P030/063	63B	4	6259
6,8	143	1,7	200,00	NMRV-P040/063	63B	4	6259
6,8	147	2,9	200,00	NMRV-P040/075	63B	4	7380
6,8	154	4,0	200,00	NMRV-P040/090	63B	4	8174
6,8	138	0,9	200,00	NMRV030/050	63B	4	4788
6,8	141	0,8	200,00	NMRV040/050	63B	4	4788
6,1	174	0,8	236,25	HA31+NMRV050	63B	4	4840
6,1	153	1,6	218,18	HW030+NMRV-P063	63B	4	6270

## 0,18 kW

n2 [rpm]	M2 [Nm]	fs	i	Gear reducer	Size	Motor Pole	Fr2 [N]
6,1	176	1,6	236,25	HW030+NMRV-P063	63B	4	6270
6,1	160	2,6	218,18	HW030+NMRV-P075	63B	4	7380
6,1	184	2,6	236,25	HW030+NMRV-P075	63B	4	7380
6,1	170	3,9	220,00	HW040+NMRV-P090	63B	4	8180
6,0	157	0,8	154,67	HA31+NMRV050	71A	6	4840
6,0	158	0,9	142,50	HA31+NMRV050	71A	6	4840
6,0	182	0,8	163,64	HA31+NMRV050	71A	6	4840
6,0	161	1,8	142,50	HW030+NMRV-P063	71A	6	6270
6,0	183	1,7	163,64	HW030+NMRV-P063	71A	6	6270
6,0	200	1,5	157,50	HW030+NMRV-P063	71A	6	6270
6,0	171	2,5	154,67	HW030+NMRV-P075	71A	6	7380
6,0	169	2,8	142,50	HW030+NMRV-P075	71A	6	7380
6,0	192	2,6	163,64	HW030+NMRV-P075	71A	6	7380
6,0	172	3,4	155,26	HW040+NMRV-P090	71A	6	8180
5,4	167	1,4	250,00	NMRV-P030/063	63B	4	6270
5,4	171	1,3	250,00	NMRV-P040/063	63B	4	6270
5,4	176	2,1	250,00	NMRV-P040/075	63B	4	7380
5,4	184	3,1	250,00	NMRV-P040/090	63B	4	8180
5,1	168	0,7	252,00	HA31+NMRV050	63B	4	4840
5,1	175	2,9	252,00	HW040+NMRV-P090	63B	4	8180
5,0	177	1,3	272,73	HW030+NMRV-P063	63B	4	6270
5,0	185	2,0	272,73	HW030+NMRV-P075	63B	4	7380
5,0	164	1,2	176,67	HW030+NMRV-P063	71A	6	6270
5,0	174	2,0	176,67	HW030+NMRV-P075	71A	6	7380
4,9	200	3,0	275,00	HW040+NMRV-P090	63B	4	8180
4,8	193	2,7	186,32	HW040+NMRV-P090	71A	6	8180
4,6	239	1,1	196,88	HW030+NMRV-P063	71A	6	6270
4,6	246	1,6	196,88	HW030+NMRV-P075	71A	6	7380
4,5	171	1,5	300,00	NMRV-P030/063	63B	4	6270
4,5	187	1,4	300,00	NMRV-P040/063	63B	4	6270
4,5	196	2,2	300,00	NMRV-P040/075	63B	4	7380
4,5	205	3,4	300,00	NMRV-P040/090	63B	4	8180
4,5	179	0,8	300,00	NMRV030/050	63B	4	4840
4,5	184	0,8	300,00	NMRV040/050	63B	4	4840
4,5	219	2,6	304,55	HW040+NMRV-P090	63B	4	8180
4,3	214	1,2	315,00	HW030+NMRV-P063	63B	4	6270
4,3	227	1,9	315,00	HW030+NMRV-P075	63B	4	7380
4,1	224	1,2	218,18	HW030+NMRV-P063	71A	6	6270
4,1	236	1,9	218,18	HW030+NMRV-P075	71A	6	7380
4,1	250	3,1	220,00	HW040+NMRV-P090	71A	6	8180
4,1	223	2,4	330,00	HW040+NMRV-P090	63B	4	8180
4,1	239	3,9	330,00	HW040+NMRV-P110	63B	4	10320



## 0,18 kW

n2 [rpm]	M2 [Nm]	fs	i	Gear reducer	Size	Motor Pole	Fr2 [N]
3,8	261	1,3	236,25	HW030+NMRV-P063	71A	6	6270
3,8	274	1,6	236,25	HW030+NMRV-P075	71A	6	7380
3,6	253	2,1	252,00	HW040+NMRV-P090	71A	6	8180
3,6	272	3,6	252,00	HW040+NMRV-P110	71A	6	10320
3,6	271	2,4	383,33	HW040+NMRV-P090	63B	4	8180
3,6	290	3,3	383,33	HW040+NMRV-P110	63B	4	10320
3,5	249	0,9	393,75	HW030+NMRV-P063	63B	4	6270
3,5	258	1,5	393,75	HW030+NMRV-P075	63B	4	7380
3,4	223	1,1	400,00	NMRV-P030/063	63B	4	6270
3,4	229	1,1	400,00	NMRV-P040/063	63B	4	6270
3,4	241	1,7	400,00	NMRV-P040/075	63B	4	7380
3,4	253	2,5	400,00	NMRV-P040/090	63B	4	8180
3,3	260	0,9	272,73	HW030+NMRV-P063	71A	6	6270
3,3	269	1,5	272,73	HW030+NMRV-P075	71A	6	7380
3,3	292	2,2	275,00	HW040+NMRV-P090	71A	6	8180
3,3	313	3,7	275,00	HW040+NMRV-P110	71A	6	10320
3,2	290	0,9	433,33	HW030+NMRV-P063	63B	4	6270
3,1	307	2,0	437,50	HW040+NMRV-P090	63B	4	8180
3,1	290	2,7	440,00	HW040+NMRV-P110	63B	4	10320
3,0	321	2,0	304,55	HW040+NMRV-P090	71A	6	8180
3,0	345	3,4	304,55	HW040+NMRV-P110	71A	6	10320
3,0	302	1,8	460,00	HW040+NMRV-P090	63B	4	8180
3,0	325	3,1	460,00	HW040+NMRV-P110	63B	4	10320
2,9	317	0,9	315,00	HW030+NMRV-P063	71A	6	6270
2,9	336	1,4	315,00	HW030+NMRV-P075	71A	6	7380
2,9	276	0,8	472,50	HW030+NMRV-P063	63B	4	6270
2,9	292	1,3	472,50	HW030+NMRV-P075	63B	4	7380
2,7	259	0,9	500,00	NMRV-P030/063	63B	4	6270
2,7	318	0,7	500,00	NMRV-P040/063	63B	4	6270
2,7	276	1,3	500,00	NMRV-P040/075	63B	4	7380
2,7	296	1,9	500,00	NMRV-P040/090	63B	4	8180
2,7	326	1,7	330,00	HW040+NMRV-P090	71A	6	8180
2,7	350	2,9	330,00	HW040+NMRV-P110	71A	6	10320
2,6	337	0,7	541,67	HW030+NMRV-P063	63B	4	6270
2,6	349	1,0	541,67	HW030+NMRV-P075	63B	4	7380
2,6	342	1,6	525,00	HW040+NMRV-P090	63B	4	8180
2,6	368	2,6	525,00	HW040+NMRV-P110	63B	4	10320
2,3	381	1,1	393,75	HW030+NMRV-P075	71A	6	7380
2,3	400	1,7	383,33	HW040+NMRV-P090	71A	6	8180
2,3	431	2,3	383,33	HW040+NMRV-P110	71A	6	10320
2,3	326	0,8	600,00	NMRV-P030/063	63B	4	6270
2,3	347	0,8	600,00	NMRV-P040/063	63B	4	6270

## 0,18 kW

n2 [rpm]	M2 [Nm]	fs	i	Gear reducer	Size	Motor Pole	Fr2 [N]
2,3	364	1,2	600,00	NMRV-P040/075	63B	4	7380
2,3	381	1,8	600,00	NMRV-P040/090	63B	4	8180
2,2	367	1,2	613,33	HW040+NMRV-P090	63B	4	8180
2,2	396	2,0	613,33	HW040+NMRV-P110	63B	4	10320
2,1	454	1,5	437,50	HW040+NMRV-P090	71A	6	8180
2,0	395	1,0	650,00	HW030+NMRV-P075	63B	4	7380
2,0	446	1,3	460,00	HW040+NMRV-P090	71A	6	8180
2,0	427	1,9	440,00	HW040+NMRV-P110	71A	6	10320
2,0	480	2,2	460,00	HW040+NMRV-P110	71A	6	10320
1,9	415	1,0	700,00	HW040+NMRV-P090	63B	4	8180
1,9	449	1,8	700,00	HW040+NMRV-P110	63B	4	10320
1,9	431	0,9	472,50	HW030+NMRV-P075	71A	6	7380
1,8	438	1,0	750,00	NMRV-P040/075	63B	4	7380
1,8	459	1,5	750,00	NMRV-P040/090	63B	4	8180
1,7	411	0,8	766,67	HW040+NMRV-P090	63B	4	8180
1,7	448	1,4	766,67	HW040+NMRV-P110	63B	4	10320
1,7	506	1,1	525,00	HW040+NMRV-P090	71A	6	8180
1,7	545	1,7	525,00	HW040+NMRV-P110	71A	6	10320
1,5	464	0,8	875,00	HW040+NMRV-P090	63B	4	8180
1,5	507	1,3	875,00	HW040+NMRV-P110	63B	4	10320
1,5	491	0,9	900,00	NMRV-P040/075	63B	4	7380
1,5	514	1,3	900,00	NMRV-P040/090	63B	4	8180
1,5	541	0,9	613,33	HW040+NMRV-P090	71A	6	8180
1,5	587	1,4	613,33	HW040+NMRV-P110	71A	6	10320
1,3	614	0,8	700,00	HW040+NMRV-P090	71A	6	8180
1,3	666	1,3	700,00	HW040+NMRV-P110	71A	6	10320
1,2	658	1,0	766,67	HW040+NMRV-P110	71A	6	10320
1,1	608	0,7	1200,00	NMRV-P040/075	63B	4	7380
1,1	638	1,1	1200,00	NMRV-P040/090	63B	4	8180
1,1	656	1,0	1200,00	NMRV-P050/090	63B	4	8180
1,1	656	1,9	1200,00	NMRV-P050/110	63B	4	10320
1,0	747	0,9	875,00	HW040+NMRV-P110	71A	6	10320
0,9	760	0,9	1500,00	NMRV-P040/090	63B	4	8180
0,9	773	0,9	1500,00	NMRV-P050/090	63B	4	8180
0,9	773	1,6	1500,00	NMRV-P050/110	63B	4	10320
0,8	855	0,8	1800,00	NMRV-P040/090	63B	4	8180
0,8	868	0,8	1800,00	NMRV-P050/090	63B	4	8180
0,8	868	1,4	1800,00	NMRV-P050/110	63B	4	10320
0,6	1124	1,0	2400,00	NMRV-P050/110	63B	4	10320
0,4	1340	0,8	3000,00	NMRV-P050/110	63B	4	10320

## 0,25 kW

n <sub>2</sub> [rpm]	M <sub>2</sub> [Nm]	f <sub>s</sub>	i	Gear reducer	Motor		Fr <sub>2</sub> [N]
					Size	Pole	
564,0	4	3,2	5,00	NMRV030	63B	2	474
375,7	6	2,3	7,50	NMRV030	63B	2	542
282,0	7	1,8	10,00	NMRV030	63B	2	597
282,0	8	3,9	10,00	NMRV040	63B	2	1149
270,0	8	2,5	5,00	NMRV030	63D	4	597
188,3	10	1,2	15,00	NMRV030	63B	2	683
188,3	11	2,9	15,00	NMRV040	63B	2	1315
182,0	12	3,6	5,00	NMRV040	71B	6	1331
180,0	12	1,6	7,50	NMRV030	63D	4	683
180,0	12	3,7	7,50	NMRV040	63D/71A	4	1315
141,0	13	0,9	20,00	NMRV030	63B	2	752
141,0	14	2,0	20,00	NMRV040	63B	2	1447
138,0	15	3,0	10,00	NMRV040	63D/71A	4	1447
135,0	15	1,3	10,00	NMRV030	63D	4	752
121,3	17	2,7	7,50	NMRV040	71B	6	1524
112,8	16	1,0	25,00	NMRV030	63B	2	810
112,8	17	1,6	25,00	NMRV040	63B	2	1559
93,7	18	0,8	30,00	NMRV030	63B	2	861
93,7	20	1,7	30,00	NMRV040	63B	2	1657
92,3	21	3,8	15,00	NMRV050	71A	4	2274
91,0	22	2,2	10,00	NMRV040	71B	6	1677
90,0	21	0,9	15,00	NMRV030	63D	4	861
90,0	22	2,0	15,00	NMRV040	63D/71A	4	1657
70,5	25	1,2	40,00	NMRV040	63B	2	1824
70,5	25	2,3	40,00	NMRV050	63B	2	2503
69,5	27	2,8	20,00	NMRV050	71A	4	2503
67,5	28	1,5	20,00	NMRV040	63D/71A	4	1824
61,4	31	1,8	22,08	HA31+NMRV040	63D/71A	4	1922
61,4	31	3,1	22,08	HA31+NMRV050	63D/71A	4	2638
60,7	31	1,6	15,00	NMRV040	71B	6	1920
60,7	32	2,9	15,00	NMRV050	71B	6	2635
57,3	34	1,8	23,75	HA31+NMRV040	63D/71A	4	1969
57,3	34	2,1	23,75	HA31+NMRV050	63D/71A	4	2703
56,4	29	1,0	50,00	NMRV040	63B	2	1964
56,4	30	1,8	50,00	NMRV050	63B	2	2696
55,6	34	3,9	25,00	NMRV-P063	71A	4	3524
55,6	33	2,1	25,00	NMRV050	71A	4	2696
54,6	36	1,8	25,50	HA31+NMRV040	63D/71A	4	1982
54,6	36	2,1	25,50	HA31+NMRV050	63D/71A	4	2721
54,2	30	0,7	25,00	NMRV030	63D	4	1021
54,2	33	1,1	25,00	NMRV040	63D/71A	4	1964
47,3	34	0,8	60,00	NMRV040	63B	2	2087

## 0,25 kW

n <sub>2</sub> [rpm]	M <sub>2</sub> [Nm]	f <sub>s</sub>	i	Gear reducer	Motor		Fr <sub>2</sub> [N]
					Size	Pole	
47,3	34	1,5	60,00	NMRV050	63B	2	2865
46,0	41	1,4	29,44	HA31+NMRV040	63D/71A	4	2116
46,0	41	2,8	29,44	HA31+NMRV050	63D/71A	4	2904
45,7	38	2,3	30,00	NMRV050	71A	4	2865
45,5	41	3,9	20,00	NMRV-P063	71B	6	3791
45,5	40	1,2	20,00	NMRV040	71B	6	2113
45,5	41	2,0	20,00	NMRV050	71B	6	2900
45,0	38	1,2	30,00	NMRV040	63D/71A	4	2087
43,0	45	1,5	31,50	HA31+NMRV040	63D/71A	4	2164
43,0	45	1,6	31,50	HA31+NMRV050	63D/71A	4	2970
41,5	45	1,4	22,08	HA31+NMRV040	71B	6	2184
41,5	46	2,3	22,08	HA31+NMRV050	71B	6	2997
38,4	50	1,3	23,75	HA31+NMRV040	71B	6	2237
38,4	50	1,5	23,75	HA31+NMRV050	71B	6	3071
37,8	50	1,3	35,63	HA31+NMRV040	63D/71A	4	2254
37,8	50	2,1	35,63	HA31+NMRV050	63D/71A	4	3094
36,4	49	3,0	25,00	NMRV-P063	71B	6	4084
36,4	47	0,9	25,00	NMRV040	71B	6	2276
36,4	48	1,5	25,00	NMRV050	71B	6	3124
35,4	53	1,2	25,50	HA31+NMRV040	71B	6	2291
35,4	53	1,5	25,50	HA31+NMRV050	71B	6	3145
35,2	42	1,1	80,00	NMRV050	63B	2	3153
34,8	54	3,8	38,67	HW030+NMRV-P063	63D/71A	4	4156
34,7	49	3,0	40,00	NMRV-P063	71A	4	4122
33,8	47	0,9	40,00	NMRV040	63D/71A	4	2298
33,8	48	1,7	40,00	NMRV050	63D/71A	4	3153
32,7	57	1,2	40,91	HA31+NMRV040	63D/71A	4	2361
32,7	58	1,9	40,91	HA31+NMRV050	63D/71A	4	3240
31,3	58	1,1	29,44	HA31+NMRV040	71B	6	2404
31,3	60	2,1	29,44	HA31+NMRV050	71B	6	3299
31,3	61	3,7	29,00	HW030+NMRV-P063	71B	6	4291
30,7	58	1,1	44,17	HA31+NMRV040	63D/71A	4	2422
30,7	58	1,9	44,17	HA31+NMRV050	63D/71A	4	3324
30,7	59	3,4	44,17	HW030+NMRV-P063	63D/71A	4	4345
30,3	56	3,1	30,00	NMRV-P063	71B	6	4339
30,3	52	1,0	30,00	NMRV040	71B	6	2419
30,3	54	1,7	30,00	NMRV050	71B	6	3320
29,3	66	1,0	31,50	HA31+NMRV040	71B	6	2458
29,3	66	1,2	31,50	HA31+NMRV050	71B	6	3374
28,6	64	1,0	47,50	HA31+NMRV040	63D/71A	4	2481
28,6	66	1,9	47,50	HA31+NMRV050	63D/71A	4	3406
28,6	66	3,3	47,50	HW030+NMRV-P063	63D/71A	4	4452

## 0,25 kW

n <sub>2</sub> [rpm]	M <sub>2</sub> [Nm]	f <sub>s</sub>	i	Gear reducer	Motor		Fr <sub>2</sub> [N]
					Size	Pole	
28,2	49	0,8	100,00	NMRV050	63B	2	3397
27,8	58	2,5	50,00	NMRV-P063	71A	4	4440
27,8	60	3,7	50,00	NMRV-P075	71A	4	5241
26,6	56	0,7	50,00	NMRV040	63D	4	2475
26,6	57	1,3	50,00	NMRV050	63D/71A	4	3397
25,3	72	1,0	35,63	HA31+NMRV040	71B	6	2561
25,3	73	1,5	35,63	HA31+NMRV050	71B	6	3515
24,5	72	0,9	54,55	HA31+NMRV040	63D/71A	4	2598
24,5	74	1,7	54,55	HA31+NMRV050	63D/71A	4	3566
23,5	75	2,9	58,00	HW030+NMRV-P063	63D/71A	4	4758
23,3	78	3,0	38,67	HW030+NMRV-P063	71B	6	4722
23,3	69	2,4	40,00	NMRV-P063	71B	6	4776
23,3	72	3,8	40,00	NMRV-P075	71B	6	5637
23,3	66	0,7	40,00	NMRV040	71B	6	2662
23,3	67	1,3	40,00	NMRV050	71B	6	3654
22,8	65	2,1	60,00	NMRV-P063	71A	4	4719
22,8	68	3,1	60,00	NMRV-P075	71A	4	5569
22,5	73	0,8	58,89	HA31+NMRV040	63D/71A	4	2665
22,5	74	1,3	58,89	HA31+NMRV050	63D/71A	4	3658
22,5	64	1,1	60,00	NMRV050	63D/71A	4	3610
22,2	83	0,9	40,91	HA31+NMRV040	71B	6	2682
22,2	84	1,4	40,91	HA31+NMRV050	71B	6	3681
21,5	83	0,8	63,00	HA31+NMRV040	63D/71A	4	2726
21,5	86	1,5	63,00	HA31+NMRV050	63D/71A	4	3742
20,2	83	0,8	44,17	HA31+NMRV040	71B	6	2752
20,2	84	1,5	44,17	HA31+NMRV050	71B	6	3777
20,2	85	2,7	44,17	HW030+NMRV-P063	71B	6	4937
20,2	87	3,0	44,17	HW030+NMRV-P075	71B	6	5827
19,4	90	0,7	71,25	HA31+NMRV040	63D/71A	4	2840
19,4	91	1,4	71,25	HA31+NMRV050	63D/71A	4	3898
19,4	92	2,6	71,25	HW030+NMRV-P063	63D/71A	4	5096
19,4	95	4,0	71,25	HW030+NMRV-P075	63D	4	6015
19,2	93	0,8	47,50	HA31+NMRV040	71B	6	2819
19,2	96	1,4	47,50	HA31+NMRV050	71B	6	3869
19,2	95	2,6	47,50	HW030+NMRV-P063	71B	6	5058
19,2	97	3,6	47,50	HW030+NMRV-P075	71B	6	5970
18,2	81	2,0	50,00	NMRV-P063	71B	6	5145
18,2	84	3,0	50,00	NMRV-P075	71B	6	6073
18,2	79	1,0	50,00	NMRV050	71B	6	3936
17,9	102	0,7	78,75	HA31+NMRV040	71A	4	2886
17,4	107	1,2	78,75	HA31+NMRV050	63D/71A	4	4031
17,4	97	2,2	77,33	HW030+NMRV-P063	63D/71A	4	5237

## 0,25 kW

n2 [rpm]	M2 [Nm]	fs	i	Gear reducer	Motor		Fr2 [N]
					Size	Pole	
17,4	99	3,8	77,33	HW030+NMRV-P075	63D/71A	4	6181
17,4	76	0,8	80,00	NMRV050	63D/71A	4	3973
17,2	110	1,2	54,55	HA31+NMRV050	71B	6	4052
16,9	81	1,5	80,00	NMRV-P063	71A	4	5193
16,9	85	2,3	80,00	NMRV-P075	71A	4	6130
16,4	105	2,4	81,82	HW030+NMRV-P063	63D/71A	4	5336
16,4	108	3,6	81,82	HW030+NMRV-P075	63D/71A	4	6298
16,2	110	2,3	58,00	HW030+NMRV-P063	71B	6	5406
16,2	113	2,5	58,00	HW030+NMRV-P075	71B	6	6381
15,3	98	1,2	88,33	HA31+NMRV050	63D/71A	4	4188
15,3	100	2,1	88,33	HW030+NMRV-P063	63D/71A	4	5474
15,3	104	3,3	88,33	HW030+NMRV-P075	63D/71A	4	6461
15,2	106	1,1	58,89	HA31+NMRV050	71B	6	4157
15,2	93	1,6	60,00	NMRV-P063	71B	6	5467
15,2	98	2,5	60,00	NMRV-P075	71B	6	6453
15,2	88	0,9	60,00	NMRV050	71B	6	4183
14,3	119	1,1	94,50	HA31+NMRV050	63D/71A	4	4283
14,3	116	2,0	95,00	HW030+NMRV-P063	63D/71A	4	5609
14,3	120	3,4	95,00	HW030+NMRV-P075	63D/71A	4	6620
14,2	127	1,1	63,00	HA31+NMRV050	71B	6	4251
13,9	90	1,3	100,00	NMRV-P063	71A	4	5595
13,9	97	1,9	100,00	NMRV-P075	71A	4	6603
13,8	116	2,2	100,00	NMRV-P040/063	63D/71A	4	4967
13,8	117	3,0	100,00	NMRV-P040/075	63D/71A	4	5863
13,8	120	3,0	100,00	NMRV-P040/090	63D/71A	4	6487
13,8	116	1,2	100,00	NMRV040/050	63D/71A	4	3800
13,5	110	1,3	100,00	NMRV-P030/063	63D	4	4967
13,5	110	1,2	100,00	NMRV030/050	63D	4	3800
13,3	123	0,9	102,00	HA31+NMRV050	63D/71A	4	4394
13,1	133	1,0	71,25	HA31+NMRV050	71B	6	4429
13,1	134	2,0	71,25	HW030+NMRV-P063	71B	6	5790
13,1	137	2,2	71,25	HW030+NMRV-P075	71B	6	6834
12,3	131	0,9	109,09	HA31+NMRV050	63D/71A	4	4493
12,3	133	1,8	109,09	HW030+NMRV-P063	63D/71A	4	5873
12,3	137	3,1	109,09	HW030+NMRV-P075	63D/71A	4	6932
12,1	138	1,8	77,33	HW030+NMRV-P063	71B	6	5950
12,1	142	3,0	77,33	HW030+NMRV-P075	71B	6	7023
11,2	148	0,9	118,13	HA31+NMRV050	63D/71A	4	4614
11,2	150	1,7	118,13	HW030+NMRV-P063	63D/71A	4	6031
11,2	133	2,9	116,00	HW030+NMRV-P075	63D/71A	4	7076
11,1	158	0,9	78,75	HA31+NMRV050	71B	6	4579
11,1	153	1,8	81,82	HW030+NMRV-P063	71B	6	6063

## 0,25 kW

n2 [rpm]	M2 [Nm]	fs	i	Gear reducer	Motor Size	Pole	Fr2 [N]
11,1	157	2,0	81,82	HW030+NMRV-P075	71B	6	7156
11,1	111	1,2	80,00	NMRV-P063	71B	6	6018
11,1	118	1,9	80,00	NMRV-P075	71B	6	7103
10,2	145	0,7	127,50	HA31+NMRV050	63D/71A	4	4733
10,2	159	1,4	136,36	HW030+NMRV-P063	63D/71A	4	6270
10,2	163	2,1	136,36	HW030+NMRV-P075	63D/71A	4	7380
10,2	171	3,7	137,50	HW040+NMRV-P090	63D/71A	4	8180
10,1	138	1,0	88,33	HA31+NMRV050	71B	6	4758
10,1	176	0,8	94,50	HA31+NMRV050	71B	6	4840
10,1	141	1,8	88,33	HW030+NMRV-P063	71B	6	6220
10,1	147	2,7	88,33	HW030+NMRV-P075	71B	6	7341
9,2	152	0,7	154,67	HA31+NMRV050	63D/71A	4	4840
9,2	151	0,9	142,50	HA31+NMRV050	63D/71A	4	4840
9,2	153	1,6	142,50	HW030+NMRV-P063	63D/71A	4	6270
9,2	163	2,2	154,67	HW030+NMRV-P075	63D/71A	4	7380
9,2	160	2,6	142,50	HW030+NMRV-P075	63D/71A	4	7380
9,2	168	3,1	155,26	HW040+NMRV-P090	63D/71A	4	8180
9,2	162	1,6	150,00	NMRV-P040/063	63D/71A	4	5686
9,2	166	2,6	150,00	NMRV-P040/075	63D/71A	4	6712
9,2	171	3,0	150,00	NMRV-P040/090	63D/71A	4	7426
9,2	175	3,8	150,00	NMRV-P050/090	71A	4	7426
9,2	160	0,9	150,00	NMRV040/050	63D/71A	4	4350
9,1	169	1,6	95,00	HW030+NMRV-P063	71B	6	6270
9,1	174	2,6	95,00	HW030+NMRV-P075	71B	6	7380
9,1	126	1,0	100,00	NMRV-P063	71B	6	6270
9,1	134	1,4	100,00	NMRV-P075	71B	6	7380
9,0	154	1,3	150,00	NMRV-P030/063	63D	4	5686
9,0	152	0,9	150,00	NMRV030/050	63D	4	4350
8,2	171	0,8	163,64	HA31+NMRV050	63D/71A	4	4840
8,2	174	1,5	163,64	HW030+NMRV-P063	63D/71A	4	6270
8,2	188	1,4	157,50	HW030+NMRV-P063	63D/71A	4	6270
8,2	182	2,4	163,64	HW030+NMRV-P075	63D/71A	4	7380
8,2	193	3,8	165,00	HW040+NMRV-P090	63D/71A	4	8180
8,1	193	1,4	109,09	HW030+NMRV-P063	71B	6	6270
8,1	219	1,2	118,13	HW030+NMRV-P063	71B	6	6270
8,1	191	2,3	116,00	HW030+NMRV-P075	71B	6	7380
8,1	198	2,4	109,09	HW030+NMRV-P075	71B	6	7380
8,1	209	3,6	110,00	HW040+NMRV-P090	71B	6	8180
7,2	196	0,7	189,00	HA31+NMRV050	63D/71A	4	4840
7,2	162	1,1	176,67	HW030+NMRV-P063	63D/71A	4	6270
7,2	225	1,1	196,88	HW030+NMRV-P063	63D/71A	4	6270
7,2	171	1,8	176,67	HW030+NMRV-P075	63D/71A	4	7380

## 0,25 kW

n2 [rpm]	M2 [Nm]	fs	i	Gear reducer	Motor		Fr2 [N]
					Size	Pole	
7,2	232	1,6	196,88	HW030+NMRV-P075	63D/71A	4	7380
7,2	189	2,5	186,32	HW040+NMRV-P090	63D/71A	4	8180
7,1	230	1,1	136,36	HW030+NMRV-P063	71B	6	6270
7,1	237	1,7	136,36	HW030+NMRV-P075	71B	6	7380
7,1	216	3,5	126,00	HW040+NMRV-P090	71B	6	8180
7,1	250	2,8	137,50	HW040+NMRV-P090	71B	6	8180
7,1	261	3,7	137,50	HW040+NMRV-P110	71B	6	10320
6,9	204	1,2	200,00	NMRV-P040/063	63D/71A	4	6259
6,9	211	2,0	200,00	NMRV-P040/075	63D/71A	4	7380
6,9	219	2,8	200,00	NMRV-P040/090	63D/71A	4	8174
6,9	225	2,7	200,00	NMRV-P050/090	71A	4	8174
6,8	194	1,3	200,00	NMRV-P030/063	63D	4	6259
6,1	214	1,2	218,18	HW030+NMRV-P063	63D/71A	4	6270
6,1	245	1,1	236,25	HW030+NMRV-P063	63D/71A	4	6270
6,1	224	1,8	218,18	HW030+NMRV-P075	63D/71A	4	7380
6,1	258	1,8	236,25	HW030+NMRV-P075	63D/71A	4	7380
6,1	238	2,8	220,00	HW040+NMRV-P090	63D/71A	4	8180
6,1	221	1,3	142,50	HW030+NMRV-P063	71B	6	6270
6,1	251	1,2	163,64	HW030+NMRV-P063	71B	6	6270
6,1	275	1,0	157,50	HW030+NMRV-P063	71B	6	6270
6,1	234	1,8	154,67	HW030+NMRV-P075	71B	6	7380
6,1	231	2,0	142,50	HW030+NMRV-P075	71B	6	7380
6,1	264	1,8	163,64	HW030+NMRV-P075	71B	6	7380
6,1	236	2,4	155,26	HW040+NMRV-P090	71B	6	8180
6,0	257	3,5	252,00	HW040+NMRV-P110	71A	4	10320
5,5	245	1,0	250,00	NMRV-P040/063	63D/71A	4	6270
5,5	252	1,5	250,00	NMRV-P040/075	63D/71A	4	7380
5,5	263	2,2	250,00	NMRV-P040/090	63D/71A	4	8180
5,5	269	2,1	250,00	NMRV-P050/090	71A	4	8180
5,4	232	1,0	250,00	NMRV-P030/063	63D	4	6270
5,1	245	2,0	252,00	HW040+NMRV-P090	63D/71A	4	8180
5,1	226	0,9	176,67	HW030+NMRV-P063	71B	6	6270
5,1	238	1,4	176,67	HW030+NMRV-P075	71B	6	7380
5,1	279	3,0	165,00	HW040+NMRV-P090	71B	6	8180
4,9	247	0,9	272,73	HW030+NMRV-P063	63D/71A	4	6270
4,9	258	1,4	272,73	HW030+NMRV-P075	63D/71A	4	7380
4,9	279	2,1	275,00	HW040+NMRV-P090	63D/71A	4	8180
4,9	297	3,7	275,00	HW040+NMRV-P110	63D/71A	4	10320
4,9	265	1,9	186,32	HW040+NMRV-P090	71B	6	8180
4,9	284	3,2	186,32	HW040+NMRV-P110	71B	6	10320
4,7	328	0,8	196,88	HW030+NMRV-P063	71B	6	6270
4,7	338	1,2	196,88	HW030+NMRV-P075	71B	6	7380



## 0,25 kW

n2 [rpm]	M2 [Nm]	fs	i	Gear reducer	Motor		Fr2 [N]
					Size	Pole	
4,6	267	1,0	300,00	NMRV-P040/063	63D/71A	4	6270
4,6	280	1,6	300,00	NMRV-P040/075	63D/71A	4	7380
4,6	293	2,4	300,00	NMRV-P040/090	63D/71A	4	8180
4,6	300	2,3	300,00	NMRV-P050/090	71A	4	8180
4,5	239	1,0	300,00	NMRV-P030/063	63D	4	6270
4,4	306	1,8	304,55	HW040+NMRV-P090	63D/71A	4	8180
4,4	327	3,0	304,55	HW040+NMRV-P110	63D/71A	4	10320
4,3	300	0,9	315,00	HW030+NMRV-P063	63D/71A	4	6270
4,3	317	1,4	315,00	HW030+NMRV-P075	63D/71A	4	7380
4,1	307	0,9	218,18	HW030+NMRV-P063	71B	6	6270
4,1	324	1,4	218,18	HW030+NMRV-P075	71B	6	7380
4,1	344	2,2	220,00	HW040+NMRV-P090	71B	6	8180
4,1	360	3,5	220,00	HW040+NMRV-P110	71B	6	10320
4,1	312	1,6	330,00	HW040+NMRV-P090	63D/71A	4	8180
4,1	334	2,8	330,00	HW040+NMRV-P110	63D/71A	4	10320
3,8	358	1,0	236,25	HW030+NMRV-P063	71B	6	6270
3,8	376	1,2	236,25	HW030+NMRV-P075	71B	6	7380
3,6	348	1,5	252,00	HW040+NMRV-P090	71B	6	8180
3,6	374	2,6	252,00	HW040+NMRV-P110	71B	6	10320
3,5	362	1,1	393,75	HW030+NMRV-P075	63D/71A	4	7380
3,5	379	1,6	383,33	HW040+NMRV-P090	63D/71A	4	8180
3,5	406	2,4	383,33	HW040+NMRV-P110	63D/71A	4	10320
3,5	341	0,7	393,75	HW030+NMRV-P063	71A	4	6270
3,5	327	0,8	400,00	NMRV-P040/063	63D/71A	4	6270
3,5	344	1,2	400,00	NMRV-P040/075	63D/71A	4	7380
3,5	362	1,7	400,00	NMRV-P040/090	63D/71A	4	8180
3,5	371	1,7	400,00	NMRV-P050/090	71A	4	8180
3,5	389	3,1	400,00	NMRV-P050/110	71A	4	10320
3,5	389	3,1	400,00	NMRV-P063/110	71A	4	10320
3,4	310	0,8	400,00	NMRV-P030/063	63D	4	6270
3,3	370	1,1	272,73	HW030+NMRV-P075	71B	6	7380
3,3	401	1,6	275,00	HW040+NMRV-P090	71B	6	8180
3,3	429	2,7	275,00	HW040+NMRV-P110	71B	6	10320
3,1	429	1,5	437,50	HW040+NMRV-P090	63D/71A	4	8180
3,1	407	1,9	440,00	HW040+NMRV-P110	63D/71A	4	10320
3,0	441	1,4	304,55	HW040+NMRV-P090	71B	6	8180
3,0	474	2,4	304,55	HW040+NMRV-P110	71B	6	10320
3,0	423	1,3	460,00	HW040+NMRV-P090	63D/71A	4	8180
3,0	455	2,1	460,00	HW040+NMRV-P110	63D/71A	4	10320
2,9	462	1,0	315,00	HW030+NMRV-P075	71B	6	7380
2,9	410	0,9	472,50	HW030+NMRV-P075	63D/71A	4	7380
2,8	394	0,9	500,00	NMRV-P040/075	63D/71A	4	7380

## 0,25 kW

n2 [rpm]	M2 [Nm]	fs	i	Gear reducer	Motor		Fr2 [N]
					Size	Pole	
2,8	423	1,3	500,00	NMRV-P040/090	63D/71A	4	8180
2,8	495	1,2	500,00	NMRV-P050/090	71A	4	8180
2,8	516	2,3	500,00	NMRV-P050/110	71A	4	10320
2,8	528	2,2	500,00	NMRV-P063/110	71A	4	10320
2,8	463	3,4	500,00	NMRV-P063/130	71A	4	13500
2,7	447	1,2	330,00	HW040+NMRV-P090	71B	6	8180
2,7	481	2,1	330,00	HW040+NMRV-P110	71B	6	10320
2,6	479	1,1	525,00	HW040+NMRV-P090	63D/71A	4	8180
2,6	515	1,8	525,00	HW040+NMRV-P110	63D/71A	4	10320
2,5	489	0,7	541,67	HW030+NMRV-P075	63D	4	7380
2,3	524	0,8	393,75	HW030+NMRV-P075	71B	6	7380
2,3	550	1,2	383,33	HW040+NMRV-P090	71B	6	8180
2,3	591	1,7	383,33	HW040+NMRV-P110	71B	6	10320
2,3	521	0,9	600,00	NMRV-P040/075	63D/71A	4	7380
2,3	546	1,3	600,00	NMRV-P040/090	63D/71A	4	8180
2,3	552	1,3	600,00	NMRV-P050/090	71A	4	8180
2,3	552	2,3	600,00	NMRV-P050/110	71A	4	10320
2,3	566	2,3	600,00	NMRV-P063/110	71A	4	10320
2,3	575	3,1	600,00	NMRV-P063/130	71A	4	13500
2,2	512	0,8	613,33	HW040+NMRV-P090	63D/71A	4	8180
2,2	554	1,4	613,33	HW040+NMRV-P110	63D/71A	4	10320
2,1	624	1,1	437,50	HW040+NMRV-P090	71B	6	8180
2,0	613	0,9	460,00	HW040+NMRV-P090	71B	6	8180
2,0	587	1,4	440,00	HW040+NMRV-P110	71B	6	10320
2,0	660	1,6	460,00	HW040+NMRV-P110	71B	6	10320
1,9	581	0,7	700,00	HW040+NMRV-P090	63D/71A	4	8180
1,9	629	1,3	700,00	HW040+NMRV-P110	63D/71A	4	10320
1,8	627	0,7	750,00	NMRV-P040/075	63D/71A	4	7380
1,8	656	1,1	750,00	NMRV-P040/090	63D/71A	4	8180
1,8	665	1,1	750,00	NMRV-P050/090	71A	4	8180
1,8	665	1,9	750,00	NMRV-P050/110	71A	4	10320
1,8	682	1,9	750,00	NMRV-P063/110	71A	4	10320
1,8	692	2,6	750,00	NMRV-P063/130	71A	4	13500
1,8	671	3,5	750,00	NMRV-P063/150	71A	4	18000
1,7	627	1,0	766,67	HW040+NMRV-P110	63D/71A	4	10320
1,7	695	0,8	525,00	HW040+NMRV-P090	71B	6	8180
1,7	749	1,2	525,00	HW040+NMRV-P110	71B	6	10320
1,5	709	0,9	875,00	HW040+NMRV-P110	63D/71A	4	10320
1,5	735	1,0	900,00	NMRV-P040/090	63D/71A	4	8180
1,5	756	0,9	900,00	NMRV-P050/090	71A	4	8180
1,5	756	1,7	900,00	NMRV-P050/110	71A	4	10320
1,5	777	1,6	900,00	NMRV-P063/110	71A	4	10320

## 0,25 kW

n2 [rpm]	M2 [Nm]	fs	i	Gear reducer	Size	Motor Pole	Fr2 [N]
1,5	789	2,2	900,00	NMRV-P063/130	71A	4	13500
1,5	846	2,5	900,00	NMRV-P063/150	71A	4	18000
1,5	806	1,0	613,33	HWO40+NMRV-P110	71B	6	10320
1,3	915	0,9	700,00	HWO40+NMRV-P110	71B	6	10320
1,2	904	0,7	766,67	HWO40+NMRV-P110	71B	6	10320
1,2	912	0,8	1200,00	NMRV-P040/090	63D/71A	4	8180
1,2	939	0,8	1200,00	NMRV-P050/090	63D/71A	4	8180
1,2	939	1,4	1200,00	NMRV-P050/110	63D/71A	4	10320
1,2	980	1,3	1200,00	NMRV-P063/110	71A	4	10320
1,2	995	1,8	1200,00	NMRV-P063/130	71A	4	13500
1,2	1020	2,6	1200,00	NMRV-P063/150	71A	4	18000
0,9	1105	1,2	1500,00	NMRV-P050/110	63D/71A	4	10320
0,9	1156	1,1	1500,00	NMRV-P063/110	71A	4	10320
0,9	1173	1,5	1500,00	NMRV-P063/130	71A	4	13500
0,9	1198	2,0	1500,00	NMRV-P063/150	71A	4	18000
0,8	1243	1,0	1800,00	NMRV-P050/110	63D/71A	4	10320
0,8	1305	1,0	1800,00	NMRV-P063/110	71A	4	10320
0,8	1325	1,3	1800,00	NMRV-P063/130	71A	4	13500
0,8	1422	1,5	1800,00	NMRV-P063/150	71A	4	18000
0,6	1608	0,7	2400,00	NMRV-P050/110	63D/71A	4	10320
0,6	1688	0,7	2400,00	NMRV-P063/110	71A	4	10320
0,6	1688	1,0	2400,00	NMRV-P063/130	71A	4	13500
0,6	1714	1,6	2400,00	NMRV-P063/150	71A	4	18000
0,5	2013	0,8	3000,00	NMRV-P063/130	71A	4	13500
0,5	2013	1,2	3000,00	NMRV-P063/150	71A	4	18000
0,3	2471	0,9	4000,00	NMRV-P063/150	71A	4	18000
0,3	2769	0,8	5000,00	NMRV-P063/150	71A	4	18000

## 0,37 kW

n2 [rpm]	M2 [Nm]	fs	i	Gear reducer	Size	Motor Pole	Fr2 [N]
558,0	6	2,1	5,00	NMRV030	63C	2	474
372,0	8	1,6	7,50	NMRV030	63C	2	542
372,0	8	3,3	7,50	NMRV040	63C	2	1044
280,0	11	3,2	5,00	NMRV040	71B	4	1149
279,0	11	1,2	10,00	NMRV030	63C	2	597
279,0	11	2,6	10,00	NMRV040	63C	2	1149
186,7	17	2,5	7,50	NMRV040	71B	4	1315
186,0	16	0,8	15,00	NMRV030	63C	2	683
186,0	16	1,9	15,00	NMRV040	63C	2	1315
180,0	17	2,5	5,00	NMRV040	71C	6	1331
140,0	22	2,0	10,00	NMRV040	71B	4	1447

## 0,37 kW

n <sub>2</sub> [rpm]	M <sub>2</sub> [Nm]	f <sub>s</sub>	i	Gear reducer	Motor		Fr <sub>2</sub> [N]
					Size	Pole	
140,0	21	1,4	20,00	NMRV040	63C	2	1447
140,0	22	3,6	10,00	NMRV050	71B	4	1987
119,7	25	1,8	7,50	NMRV040	71C	6	1524
119,7	25	3,6	7,50	NMRV050	71C/80A	6	2091
112,0	25	1,1	25,00	NMRV040	63C	2	1559
93,3	32	1,4	15,00	NMRV040	71B	4	1657
93,3	32	2,5	15,00	NMRV050	71B	4	2274
93,0	29	1,2	30,00	NMRV040	63C	2	1657
90,0	32	1,4	10,00	NMRV040	71C	6	1677
90,0	33	2,8	10,00	NMRV050	71C/80A	6	2302
70,0	41	3,6	20,00	NMRV-P063	71B	4	3272
70,0	39	1,1	20,00	NMRV040	71B	4	1824
70,0	37	0,8	40,00	NMRV040	63C	2	1824
70,0	40	1,9	20,00	NMRV050	71B	4	2503
70,0	37	1,6	40,00	NMRV050	63C	2	2503
62,9	44	1,3	22,08	HA31+NMRV040	71B	4	1894
62,9	45	2,1	22,08	HA31+NMRV050	71B	4	2599
62,9	46	4,1	22,08	HW030+NMRV-P063	71B	4	3398
60,3	48	3,6	15,00	NMRV-P063	71C/80A	6	3444
60,3	47	1,1	15,00	NMRV040	71C	6	1920
60,3	47	1,9	15,00	NMRV050	71C/80A	6	2635
58,8	49	1,3	23,75	HA31+NMRV040	71B	4	1940
58,8	49	1,5	23,75	HA31+NMRV050	71B	4	2663
56,0	44	1,2	50,00	NMRV050	63C	2	2696
55,8	50	2,6	25,00	NMRV-P063	71B	4	3524
55,8	48	0,8	25,00	NMRV040	71B	4	1964
55,8	48	1,4	25,00	NMRV050	71B	4	2696
54,8	52	1,2	25,50	HA31+NMRV040	71B	4	1987
54,8	52	1,4	25,50	HA31+NMRV050	71B	4	2727
48,7	60	3,3	29,00	HW030+NMRV-P063	71B	4	3721
47,7	58	1,0	29,44	HA31+NMRV040	71B	4	2084
47,7	59	1,9	29,44	HA31+NMRV050	71B	4	2861
47,0	51	1,0	60,00	NMRV050	63C	2	2865
46,7	57	2,8	30,00	NMRV-P063	71B	4	3745
46,7	54	0,9	30,00	NMRV040	71B	4	2087
46,7	55	1,6	30,00	NMRV050	71B	4	2865
45,0	62	2,7	20,00	NMRV-P063	71C/80A	6	3791
45,0	60	0,8	20,00	NMRV040	71C	6	2113
45,0	61	1,3	20,00	NMRV050	71C/80A	6	2900
44,6	64	1,0	31,50	HA31+NMRV040	71B	4	2132
44,6	64	1,1	31,50	HA31+NMRV050	71B	4	2926
40,9	68	1,0	22,08	HA31+NMRV040	71C/80A	6	2200

## 0,37 kW

n <sub>2</sub> [rpm]	M <sub>2</sub> [Nm]	f <sub>s</sub>	i	Gear reducer	Motor		Fr <sub>2</sub> [N]
					Size	Pole	
40,9	69	1,5	22,08	HA31+NMRV050	71C/80A	6	3020
40,9	70	3,0	22,08	HW030+NMRV-P063	71C/80A	6	3948
40,9	70	4,0	22,08	HW030+NMRV-P075	71C	6	4659
39,6	71	0,9	35,63	HA31+NMRV040	71B	4	2221
39,6	72	1,5	35,63	HA31+NMRV050	71B	4	3049
37,8	75	0,9	23,75	HA31+NMRV040	71C/80A	6	2254
37,8	75	1,0	23,75	HA31+NMRV050	71C/80A	6	3094
36,5	76	2,6	38,67	HW030+NMRV-P063	71B	4	4095
36,5	77	3,9	38,67	HW030+NMRV-P075	71B	4	4834
35,8	80	0,8	25,50	HA31+NMRV040	71C	6	2308
35,8	80	1,0	25,50	HA31+NMRV050	71C	6	3168
35,8	74	2,0	25,00	NMRV-P063	71C/80A	6	4084
35,8	76	3,2	25,00	NMRV-P075	71C/80A	6	4820
35,8	72	1,0	25,00	NMRV050	71C/80A	6	3124
35,5	72	2,0	40,00	NMRV-P063	71B	4	4122
35,5	74	3,3	40,00	NMRV-P075	71B	4	4865
35,5	69	1,2	40,00	NMRV050	71B	4	3153
35,0	63	0,7	80,00	NMRV050	63C	2	3153
34,5	81	0,8	40,91	HA31+NMRV040	71B	4	2326
34,5	82	1,3	40,91	HA31+NMRV050	71B	4	3192
31,4	82	0,7	44,17	HA31+NMRV040	71B	4	2386
31,4	83	1,4	44,17	HA31+NMRV050	71B	4	3275
31,4	84	2,4	44,17	HW030+NMRV-P063	71B	4	4281
31,4	86	3,7	44,17	HW030+NMRV-P075	71B	4	5053
30,7	88	0,7	29,44	HA31+NMRV040	71C/80A	6	2422
30,7	90	1,4	29,44	HA31+NMRV050	71C/80A	6	3324
30,7	92	2,6	29,00	HW030+NMRV-P063	71C/80A	6	4323
30,7	92	3,1	29,00	HW030+NMRV-P075	71C/80A	6	5102
29,7	84	2,1	30,00	NMRV-P063	71C/80A	6	4339
29,7	87	3,3	30,00	NMRV-P075	71C/80A	6	5122
29,7	81	1,1	30,00	NMRV050	71C/80A	6	3320
29,4	91	0,7	47,50	HA31+NMRV040	71B	4	2445
29,4	93	1,4	47,50	HA31+NMRV050	71B	4	3355
29,4	93	2,3	47,50	HW030+NMRV-P063	71B	4	4386
29,4	94	3,3	47,50	HW030+NMRV-P075	71B	4	5177
28,6	100	0,8	31,50	HA31+NMRV050	71C	6	3400
28,4	85	1,7	50,00	NMRV-P063	71B	4	4440
28,4	89	2,5	50,00	NMRV-P075	71B	4	5241
28,4	81	0,9	50,00	NMRV050	71B	4	3397
25,6	110	1,0	35,63	HA31+NMRV050	71C/80A	6	3542
25,4	106	1,2	54,55	HA31+NMRV050	71B	4	3514
24,3	108	2,0	58,00	HW030+NMRV-P063	71B	4	4688

## 0,37 kW

n2 [rpm]	M2 [Nm]	fs	i	Gear reducer	Motor		Fr2 [N]
					Size	Pole	
24,3	111	3,1	58,00	HW030+NMRV-P075	71B	4	5533
23,5	116	2,0	38,67	HW030+NMRV-P063	71C/80A	6	4758
23,5	118	2,8	38,67	HW030+NMRV-P075	71C/80A	6	5616
23,3	106	0,9	58,89	HA31+NMRV050	71B	4	3605
23,3	96	1,4	60,00	NMRV-P063	71B	4	4719
23,3	100	2,1	60,00	NMRV-P075	71B	4	5569
23,3	91	0,8	60,00	NMRV050	71B	4	3610
22,5	126	0,9	40,91	HA31+NMRV050	71C	6	3709
22,5	104	1,6	40,00	NMRV-P063	71C/80A	6	4776
22,5	109	2,6	40,00	NMRV-P075	71C/80A	6	5637
22,5	101	0,9	40,00	NMRV050	71C	6	3654
22,3	122	1,1	63,00	HA31+NMRV050	71B	4	3687
21,5	131	3,9	42,00	HW040+NMRV-P090	71C	6	6388
21,5	131	3,9	42,00	HW040+NMRV-P110	71C	6	8071
20,5	125	1,0	44,17	HA31+NMRV050	71C/80A	6	3805
20,5	127	1,8	44,17	HW030+NMRV-P063	71C/80A	6	4974
20,5	130	2,0	44,17	HW030+NMRV-P075	71C/80A	6	5871
19,4	143	0,9	47,50	HA31+NMRV050	71C/80A	6	3898
19,4	143	1,7	47,50	HW030+NMRV-P063	71C/80A	6	5096
19,4	145	2,5	47,50	HW030+NMRV-P075	71C/80A	6	6015
19,3	129	1,0	71,25	HA31+NMRV050	71B	4	3841
19,3	131	1,8	71,25	HW030+NMRV-P063	71B	4	5021
19,3	135	2,7	71,25	HW030+NMRV-P075	71B	4	5926
19,0	130	3,3	50,00	NMRV-P090	80A	6	6719
18,4	121	1,3	50,00	NMRV-P063	71C/80A	6	5145
18,4	125	2,0	50,00	NMRV-P075	71C/80A	6	6073
18,3	153	0,9	78,75	HA31+NMRV050	71B	4	3971
18,3	138	1,6	77,33	HW030+NMRV-P063	71B	4	5160
18,3	141	2,6	77,33	HW030+NMRV-P075	71B	4	6090
18,3	143	3,6	77,63	HW040+NMRV-P090	71B	4	6747
17,2	150	1,6	81,82	HW030+NMRV-P063	71B	4	5258
17,2	154	2,5	81,82	HW030+NMRV-P075	71B	4	6206
17,2	117	1,0	80,00	NMRV-P063	71B	4	5193
17,2	123	1,6	80,00	NMRV-P075	71B	4	6130
16,4	164	0,8	54,55	HA31+NMRV050	71C	6	4082
16,2	140	0,8	88,33	HA31+NMRV050	71B	4	4126
16,2	142	1,5	88,33	HW030+NMRV-P063	71B	4	5394
16,2	148	2,3	88,33	HW030+NMRV-P075	71B	4	6366
16,2	158	3,8	84,00	HW040+NMRV-P090	71B	4	6927
16,0	152	0,7	58,89	HA31+NMRV050	80A	6	4097
16,0	147	2,6	60,00	NMRV-P090	80A	6	7140
15,3	164	1,5	58,00	HW030+NMRV-P063	71C/80A	6	5447

## 0,37 kW

n2 [rpm]	M2 [Nm]	fs	i	Gear reducer	Motor		Fr2 [N]
					Size	Pole	
15,3	169	1,7	58,00	HW030+NMRV-P075	71C/80A	6	6429
15,3	139	1,1	60,00	NMRV-P063	71C/80A	6	5467
15,3	146	1,7	60,00	NMRV-P075	71C/80A	6	6453
15,2	170	0,8	94,50	HA31+NMRV050	71B	4	4220
15,2	167	1,4	95,00	HW030+NMRV-P063	71B	4	5526
15,2	172	2,3	95,00	HW030+NMRV-P075	71B	4	6523
15,2	163	3,7	93,16	HW040+NMRV-P090	71B	4	7170
14,3	190	0,7	63,00	HA31+NMRV050	71C	6	4283
14,3	188	3,8	63,00	HW040+NMRV-P090	71C/80A	6	7312
14,2	131	0,9	100,00	NMRV-P063	71B	4	5595
14,2	141	1,3	100,00	NMRV-P075	71B	4	6603
14,0	167	1,5	100,00	NMRV-P040/063	71B	4	4967
14,0	170	2,1	100,00	NMRV-P040/075	71B	4	5863
14,0	173	2,1	100,00	NMRV-P040/090	71B	4	6487
14,0	177	3,3	100,00	NMRV-P050/090	71B	4	6487
14,0	177	3,7	100,00	NMRV-P050/110	71B	4	8198
14,0	167	0,8	100,00	NMRV040/050	71B	4	3800
13,2	189	1,3	109,09	HW030+NMRV-P063	71B	4	5787
13,2	195	2,1	109,09	HW030+NMRV-P075	71B	4	6830
13,2	204	3,1	110,00	HW040+NMRV-P090	71B	4	7579
13,0	190	0,7	71,25	HA31+NMRV050	80A	6	4365
12,3	200	1,3	71,25	HW030+NMRV-P063	71C/80A	6	5833
12,3	206	1,5	71,25	HW030+NMRV-P075	71C/80A	6	6885
12,2	213	1,2	118,13	HW030+NMRV-P063	71B	4	5942
12,2	189	2,0	116,00	HW030+NMRV-P075	71B	4	6972
12,0	180	1,7	80,00	NMRV-P090	80A	6	7859
12,0	192	2,9	80,00	NMRV-P110	80A	6	9931
11,2	207	1,2	77,33	HW030+NMRV-P063	71C/80A	6	5995
11,2	229	1,2	81,82	HW030+NMRV-P063	71C/80A	6	6108
11,2	214	2,0	77,33	HW030+NMRV-P075	71C/80A	6	7076
11,2	236	1,3	81,82	HW030+NMRV-P075	71C/80A	6	7210
11,2	216	2,9	77,63	HW040+NMRV-P090	71C/80A	6	7839
11,2	166	0,8	80,00	NMRV-P063	71C/80A	6	6018
11,2	176	1,2	80,00	NMRV-P075	71C/80A	6	7103
11,2	214	3,1	126,00	HW040+NMRV-P090	71B	4	7930
10,2	211	1,2	88,33	HW030+NMRV-P063	71C/80A	6	6266
10,2	221	1,8	88,33	HW030+NMRV-P075	71C/80A	6	7380
10,2	241	2,9	84,00	HW040+NMRV-P090	71C/80A	6	8048
10,2	247	3,9	84,00	HW040+NMRV-P110	71C	6	10169
10,1	218	1,1	142,50	HW030+NMRV-P063	71B	4	6270
10,1	227	1,0	136,36	HW030+NMRV-P063	71B	4	6234
10,1	229	1,7	142,50	HW030+NMRV-P075	71B	4	7380

## 0,37 kW

n2 [rpm]	M2 [Nm]	fs	i	Gear reducer	Motor Size	Pole	Fr2 [N]
10,1	234	1,5	136,36	HW030+NMRV-P075	71B	4	7358
10,1	244	2,6	137,50	HW040+NMRV-P090	71B	4	8164
10,1	255	3,8	137,50	HW040+NMRV-P110	71B	4	10316
9,3	235	1,1	150,00	NMRV-P040/063	71B	4	5686
9,3	242	1,7	150,00	NMRV-P040/075	71B	4	6712
9,3	247	2,1	150,00	NMRV-P040/090	71B	4	7426
9,3	253	2,6	150,00	NMRV-P050/090	71B	4	7426
9,3	256	3,7	150,00	NMRV-P050/110	71B	4	9384
9,2	252	1,0	95,00	HW030+NMRV-P063	71C/80A	6	6270
9,2	260	1,7	95,00	HW030+NMRV-P075	71C/80A	6	7380
9,2	243	2,9	93,16	HW040+NMRV-P090	71C/80A	6	8180
9,2	200	1,0	100,00	NMRV-P075	71C/80A	6	7380
9,1	268	1,0	157,50	HW030+NMRV-P063	71B	4	6270
9,1	234	1,6	154,67	HW030+NMRV-P075	71B	4	7380
9,1	240	2,1	155,26	HW040+NMRV-P090	71B	4	8180
9,1	251	3,7	155,26	HW040+NMRV-P110	71B	4	10320
9,0	207	1,4	100,00	NMRV-P090	80A	6	8180
9,0	222	2,3	100,00	NMRV-P110	80A	6	10320
8,2	288	0,9	109,09	HW030+NMRV-P063	71C/80A	6	6270
8,2	286	1,5	116,00	HW030+NMRV-P075	71C/80A	6	7380
8,2	296	1,6	109,09	HW030+NMRV-P075	71C/80A	6	7380
8,2	312	2,4	110,00	HW040+NMRV-P090	71C/80A	6	8180
8,2	301	3,9	105,00	HW040+NMRV-P110	71C	6	10320
8,1	232	0,8	176,67	HW030+NMRV-P063	71B	4	6270
8,1	248	1,0	163,64	HW030+NMRV-P063	71B	4	6270
8,1	244	1,2	176,67	HW030+NMRV-P075	71B	4	7380
8,1	260	1,6	163,64	HW030+NMRV-P075	71B	4	7380
8,1	274	2,6	165,00	HW040+NMRV-P090	71B	4	8180
8,1	278	4,0	168,00	HW040+NMRV-P110	71B	4	10320
7,2	328	0,8	118,13	HW030+NMRV-P063	71C/80A	6	6270
7,2	323	2,4	126,00	HW040+NMRV-P090	71C/80A	6	8180
7,2	323	3,9	126,00	HW040+NMRV-P110	71C	6	10320
7,1	321	0,8	196,88	HW030+NMRV-P063	71B	4	6270
7,1	331	1,2	196,88	HW030+NMRV-P075	71B	4	7380
7,1	269	1,7	186,32	HW040+NMRV-P090	71B	4	8180
7,1	288	2,8	186,32	HW040+NMRV-P110	71B	4	10320
7,0	296	0,8	200,00	NMRV-P040/063	71B	4	6259
7,0	305	1,4	200,00	NMRV-P040/075	71B	4	7380
7,0	317	1,9	200,00	NMRV-P040/090	71B	4	8174
7,0	324	1,9	200,00	NMRV-P050/090	71B	4	8174
7,0	333	3,4	200,00	NMRV-P050/110	71B	4	10320
7,0	333	3,4	200,00	NMRV-P063/110	71B	4	10320



## 0,37 kW

n2 [rpm]	M2 [Nm]	fs	i	Gear reducer	Motor		Fr2 [N]
					Size	Pole	
6,1	331	0,9	142,50	HW030+NMRV-P063	71C/80A	6	6270
6,1	345	0,7	136,36	HW030+NMRV-P063	71C/80A	6	6270
6,1	351	1,2	154,67	HW030+NMRV-P075	71C/80A	6	7380
6,1	346	1,3	142,50	HW030+NMRV-P075	71C/80A	6	7380
6,1	355	1,2	136,36	HW030+NMRV-P075	71C/80A	6	7380
6,1	354	1,6	155,26	HW040+NMRV-P090	71C/80A	6	8180
6,1	375	1,8	137,50	HW040+NMRV-P090	71C/80A	6	8180
6,1	375	2,8	155,26	HW040+NMRV-P110	71C/80A	6	10320
6,1	390	2,5	137,50	HW040+NMRV-P110	71C/80A	6	10320
6,1	306	0,8	218,18	HW030+NMRV-P063	71B	4	6270
6,1	351	0,8	236,25	HW030+NMRV-P063	71B	4	6270
6,1	320	1,3	218,18	HW030+NMRV-P075	71B	4	7380
6,1	368	1,3	236,25	HW030+NMRV-P075	71B	4	7380
6,1	339	1,9	220,00	HW040+NMRV-P090	71B	4	8180
6,1	356	3,3	220,00	HW040+NMRV-P110	71B	4	10320
6,0	394	0,7	157,50	HW030+NMRV-P063	80A	6	6270
5,6	365	1,0	250,00	NMRV-P040/075	71B	4	7380
5,6	380	1,5	250,00	NMRV-P040/090	71B	4	8180
5,6	389	1,4	250,00	NMRV-P050/090	71B	4	8180
5,6	406	2,8	250,00	NMRV-P050/110	71B	4	10320
5,6	406	2,8	250,00	NMRV-P063/110	71B	4	10320
5,6	406	3,8	250,00	NMRV-P063/130	71B	4	13500
5,1	376	0,8	163,64	HW030+NMRV-P063	71C/80A	6	6270
5,1	357	0,9	176,67	HW030+NMRV-P075	71C/80A	6	7380
5,1	395	1,2	163,64	HW030+NMRV-P075	71C/80A	6	7380
5,1	418	2,0	165,00	HW040+NMRV-P090	71C/80A	6	8180
5,1	418	3,0	168,00	HW040+NMRV-P110	71C/80A	6	10320
5,1	368	1,0	272,73	HW030+NMRV-P075	71B	4	7380
5,1	350	1,4	252,00	HW040+NMRV-P090	71B	4	8180
5,1	398	1,5	275,00	HW040+NMRV-P090	71B	4	8180
5,1	375	2,3	252,00	HW040+NMRV-P110	71B	4	10320
5,1	424	2,5	275,00	HW040+NMRV-P110	71B	4	10320
4,8	396	1,3	186,32	HW040+NMRV-P090	71C/80A	6	8180
4,8	424	2,1	186,32	HW040+NMRV-P110	71C/80A	6	10320
4,7	406	1,1	300,00	NMRV-P040/075	71B	4	7380
4,7	425	1,6	300,00	NMRV-P040/090	71B	4	8180
4,7	435	1,6	300,00	NMRV-P050/090	71B	4	8180
4,7	435	2,9	300,00	NMRV-P050/110	71B	4	10320
4,7	435	2,9	300,00	NMRV-P063/110	71B	4	10320
4,7	442	4,0	300,00	NMRV-P063/130	71B	4	13500
4,6	507	0,8	196,88	HW030+NMRV-P075	71C/80A	6	7380
4,6	437	1,2	304,55	HW040+NMRV-P090	71B	4	8180

## 0,37 kW

n2 [rpm]	M2 [Nm]	fs	i	Gear reducer	Motor		Fr2 [N]
					Size	Pole	
4,6	466	2,1	304,55	HW040+NMRV-P110	71B	4	10320
4,5	452	1,0	315,00	HW030+NMRV-P075	71B	4	7380
4,3	446	1,2	330,00	HW040+NMRV-P090	71B	4	8180
4,3	477	1,9	330,00	HW040+NMRV-P110	71B	4	10320
4,1	485	0,9	218,18	HW030+NMRV-P075	71C/80A	6	7380
4,1	514	1,5	220,00	HW040+NMRV-P090	71C/80A	6	8180
4,1	539	2,4	220,00	HW040+NMRV-P110	71C/80A	6	10320
3,8	563	0,8	236,25	HW030+NMRV-P075	71C/80A	6	7380
3,7	541	1,2	383,33	HW040+NMRV-P090	71B	4	8180
3,7	580	1,6	383,33	HW040+NMRV-P110	71B	4	10320
3,6	521	1,0	252,00	HW040+NMRV-P090	71C/80A	6	8180
3,6	559	1,7	252,00	HW040+NMRV-P110	71C/80A	6	10320
3,6	517	0,8	393,75	HW030+NMRV-P075	71B	4	7380
3,5	499	0,8	400,00	NMRV-P040/075	71B	4	7380
3,5	524	1,1	400,00	NMRV-P040/090	71B	4	8180
3,5	537	1,1	400,00	NMRV-P050/090	71B	4	8180
3,5	563	2,1	400,00	NMRV-P050/110	71B	4	10320
3,5	563	2,1	400,00	NMRV-P063/110	71B	4	10320
3,5	563	2,9	400,00	NMRV-P063/130	71B	4	13500
3,3	553	0,7	272,73	HW030+NMRV-P075	71C/80A	6	7380
3,3	599	1,0	275,00	HW040+NMRV-P090	71C/80A	6	8180
3,3	643	1,8	275,00	HW040+NMRV-P110	71C/80A	6	10320
3,2	613	1,0	437,50	HW040+NMRV-P090	71B	4	8180
3,1	581	1,3	440,00	HW040+NMRV-P110	71B	4	10320
3,0	604	0,9	460,00	HW040+NMRV-P090	71B	4	8180
3,0	650	1,5	460,00	HW040+NMRV-P110	71B	4	10320
3,0	661	0,7	315,00	HW030+NMRV-P075	80A	6	7380
3,0	661	0,9	304,55	HW040+NMRV-P090	71C/80A	6	8180
3,0	709	1,6	304,55	HW040+NMRV-P110	71C/80A	6	10320
2,8	613	0,9	500,00	NMRV-P040/090	71B	4	8180
2,8	717	0,8	500,00	NMRV-P050/090	71B	4	8180
2,8	746	1,5	500,00	NMRV-P050/110	71B	4	10320
2,8	765	1,5	500,00	NMRV-P063/110	71B	4	10320
2,8	671	2,3	500,00	NMRV-P063/130	71B	4	13500
2,8	671	3,4	500,00	NMRV-P063/150	71B	4	18000
2,8	670	0,8	330,00	HW040+NMRV-P090	71C/80A	6	8180
2,8	720	1,4	330,00	HW040+NMRV-P110	71C/80A	6	10320
2,6	684	0,8	525,00	HW040+NMRV-P090	71B	4	8180
2,6	735	1,2	525,00	HW040+NMRV-P110	71B	4	10320
2,4	822	0,8	383,33	HW040+NMRV-P090	71C/80A	6	8180
2,4	885	1,1	383,33	HW040+NMRV-P110	71C/80A	6	10320
2,3	792	1,0	613,33	HW040+NMRV-P110	71B	4	10320

## 0,37 kW

n2 [rpm]	M2 [Nm]	fs	i	Gear reducer	Size	Motor Pole	Fr2 [N]
2,3	791	0,9	600,00	NMRV-P040/090	71B	4	8180
2,3	800	0,9	600,00	NMRV-P050/090	71B	4	8180
2,3	800	1,6	600,00	NMRV-P050/110	71B	4	10320
2,3	820	1,5	600,00	NMRV-P063/110	71B	4	10320
2,3	832	2,1	600,00	NMRV-P063/130	71B	4	13500
2,3	828	3,2	600,00	NMRV-P063/150	71B	4	18000
2,0	934	0,7	437,50	HWO40+NMRV-P090	71C	6	8180
2,0	878	0,9	440,00	HWO40+NMRV-P110	71C/80A	6	10320
2,0	897	0,9	700,00	HWO40+NMRV-P110	71B	4	10320
1,9	988	1,0	460,00	HWO40+NMRV-P110	71C/80A	6	10320
1,9	950	0,7	750,00	NMRV-P040/090	71B	4	8180
1,9	963	0,7	750,00	NMRV-P050/090	71B	4	8180
1,9	963	1,3	750,00	NMRV-P050/110	71B	4	10320
1,9	988	1,3	750,00	NMRV-P063/110	71B	4	10320
1,9	1003	1,7	750,00	NMRV-P063/130	71B	4	13500
1,9	972	2,4	750,00	NMRV-P063/150	71B	4	18000
1,8	894	0,7	766,67	HWO40+NMRV-P110	71B	4	10320
1,7	1121	0,8	525,00	HWO40+NMRV-P110	71C	6	10320
1,6	1095	1,1	900,00	NMRV-P050/110	71B	4	10320
1,6	1125	1,1	900,00	NMRV-P063/110	71B	4	10320
1,6	1141	1,5	900,00	NMRV-P063/130	71B	4	13500
1,6	1226	1,7	900,00	NMRV-P063/150	71B	4	18000
1,5	1154	0,7	613,33	HWO40+NMRV-P110	80A	6	10320
1,2	1360	0,9	1200,00	NMRV-P050/110	71B	4	10320
1,2	1420	0,9	1200,00	NMRV-P063/110	71B	4	10320
1,2	1441	1,2	1200,00	NMRV-P063/130	71B	4	13500
1,2	1478	1,8	1200,00	NMRV-P063/150	71B	4	18000
0,9	1600	0,8	1500,00	NMRV-P050/110	71B	4	10320
0,9	1675	0,7	1500,00	NMRV-P063/110	71B	4	10320
0,9	1700	1,0	1500,00	NMRV-P063/130	71B	4	13500
0,9	1735	1,3	1500,00	NMRV-P063/150	71B	4	18000
0,8	1918	0,9	1800,00	NMRV-P063/130	71B	4	13500
0,8	2059	1,0	1800,00	NMRV-P063/150	71B	4	18000
0,6	2483	1,1	2400,00	NMRV-P063/150	71B	4	18000
0,5	2916	0,8	3000,00	NMRV-P063/150	71B	4	18000

## 0,55 kW

n2 [rpm]	M2 [Nm]	fs	i	Gear reducer	Size	Motor Pole	Fr2 [N]
566,0	8	2,9	5,00	NMRV040	71B	2	912
377,7	12	2,2	7,50	NMRV040	71B	2	1044
283,0	16	1,8	10,00	NMRV040	71B	2	1149

## 0,55 kW

n2 [rpm]	M2 [Nm]	fs	i	Gear reducer	Motor		Fr2 [N]
					Size	Pole	
283,0	17	3,2	10,00	NMRV050	71B	2	1577
280,0	17	2,1	5,00	NMRV040	71C	4	1149
280,0	17	4,1	5,00	NMRV050	71C	4	1577
189,7	25	3,1	7,50	NMRV050	71C/80A	4	1805
188,3	24	1,3	15,00	NMRV040	71B	2	1315
188,3	24	2,4	15,00	NMRV050	71B	2	1805
188,0	25	3,3	5,00	NMRV050	80B	6	1827
187,0	24	1,7	7,50	NMRV040	71C	4	1315
142,0	32	3,3	20,00	NMRV-P063	71B	2	2597
142,0	31	0,9	20,00	NMRV040	71B	2	1447
142,0	31	1,7	20,00	NMRV050	71B	2	1987
142,0	33	2,4	10,00	NMRV050	71C/80A	4	1987
140,0	32	1,4	10,00	NMRV040	71C	4	1447
125,3	36	2,5	7,50	NMRV050	80B	6	2091
112,8	39	2,5	25,00	NMRV-P063	71B	2	2797
112,8	37	0,7	25,00	NMRV040	71B	2	1559
112,8	38	1,3	25,00	NMRV050	71B	2	2140
94,7	44	2,7	30,00	NMRV-P063	71B	2	2973
94,7	43	0,8	30,00	NMRV040	71B	2	1657
94,7	43	1,5	30,00	NMRV050	71B	2	2274
94,0	47	3,2	10,00	NMRV-P063	80B	6	3009
94,0	47	1,9	10,00	NMRV050	80B	6	2302
93,0	47	3,2	15,00	NMRV-P063	71C/80A	4	2973
93,0	47	0,9	15,00	NMRV040	71C	4	1657
93,0	47	1,7	15,00	NMRV050	71C/80A	4	2274
70,5	62	2,4	20,00	NMRV-P063	71C/80A	4	3272
70,5	63	3,8	20,00	NMRV-P075	71C/80A	4	3862
70,5	60	0,7	20,00	NMRV040	71C	4	1824
70,5	60	1,3	20,00	NMRV050	71C/80A	4	2503
70,5	57	2,0	40,00	NMRV-P063	71B	2	3272
70,5	58	3,1	40,00	NMRV-P075	71B	2	3862
70,5	55	1,1	40,00	NMRV050	71B	2	2503
63,4	67	0,8	22,08	HA31+NMRV040	71C/80A	4	1898
63,4	68	1,4	22,08	HA31+NMRV050	71C/80A	4	2606
63,4	69	2,7	22,08	HW030+NMRV-P063	71C/80A	4	3406
63,4	69	3,8	22,08	HW030+NMRV-P075	71C/80A	4	4020
62,7	68	2,5	15,00	NMRV-P063	80B	6	3444
62,7	69	3,8	15,00	NMRV-P075	80B	6	4065
62,7	67	1,4	15,00	NMRV050	80B	6	2635
59,3	72	0,8	23,75	HA31+NMRV040	71C/80A	4	1945
59,3	72	1,0	23,75	HA31+NMRV050	71C/80A	4	2670
56,4	67	1,6	50,00	NMRV-P063	71B	2	3524

## 0,55 kW

n2 [rpm]	M2 [Nm]	fs	i	Gear reducer	Motor		Fr2 [N]
					Size	Pole	
56,4	70	2,4	50,00	NMRV-P075	71B	2	4160
56,4	65	0,8	50,00	NMRV050	71B	2	2696
56,2	74	1,8	25,00	NMRV-P063	71C/80A	4	3524
56,2	76	2,9	25,00	NMRV-P075	71C/80A	4	4160
56,2	72	1,0	25,00	NMRV050	71C/80A	4	2696
55,2	77	0,8	25,50	HA31+NMRV040	71C	4	1992
55,2	77	0,9	25,50	HA31+NMRV050	71C	4	2734
48,0	88	1,3	29,44	HA31+NMRV050	71C/80A	4	2868
48,0	89	2,2	29,00	HW030+NMRV-P063	71C/80A	4	3730
48,0	89	3,2	29,00	HW030+NMRV-P075	71C/80A	4	4403
47,5	87	1,9	20,00	NMRV-P063	80B	6	3791
47,5	89	3,0	20,00	NMRV-P075	80B	6	4474
47,5	86	1,0	20,00	NMRV050	80B	6	2900
47,3	76	1,3	60,00	NMRV-P063	71B	2	3745
47,3	80	2,0	60,00	NMRV-P075	71B	2	4421
47,0	84	1,9	30,00	NMRV-P063	71C/80A	4	3745
47,0	87	2,9	30,00	NMRV-P075	71C/80A	4	4421
47,0	82	1,0	30,00	NMRV050	71C/80A	4	2865
43,9	95	0,8	31,50	HA31+NMRV050	71C	4	2933
42,5	98	1,1	22,08	HA31+NMRV050	80B	6	2965
42,5	101	2,1	22,08	HW030+NMRV-P063	80B	6	3876
42,5	100	2,8	22,08	HW030+NMRV-P075	80B	6	4574
40,4	107	3,9	23,29	HW040+NMRV-P090	80B	6	5152
40,4	107	3,9	23,29	HW040+NMRV-P110	80B	6	6510
39,4	107	0,7	23,75	HA31+NMRV050	80B	6	3038
38,8	107	1,0	35,63	HA31+NMRV050	71C/80A	4	3056
37,4	106	1,4	25,00	NMRV-P063	80B	6	4084
37,4	109	2,2	25,00	NMRV-P075	80B	6	4820
37,4	112	3,6	25,00	NMRV-P090	80B	6	5333
37,4	103	0,7	25,00	NMRV050	80B	6	3124
35,8	114	1,8	38,67	HW030+NMRV-P063	71C/80A	4	4105
35,8	114	2,6	38,67	HW030+NMRV-P075	71C/80A	4	4846
35,5	112	3,5	40,00	NMRV-P090	80A	4	5383
35,2	95	0,9	80,00	NMRV-P063	71B	2	4122
35,2	99	1,4	80,00	NMRV-P075	71B	2	4865
34,7	107	1,4	40,00	NMRV-P063	71C/80A	4	4122
34,7	110	2,2	40,00	NMRV-P075	71C/80A	4	4865
34,7	102	0,8	40,00	NMRV050	71C	4	3153
33,7	121	0,9	40,91	HA31+NMRV050	71C	4	3200
33,7	127	3,9	42,00	HW040+NMRV-P090	71C/80A	4	5511
33,7	127	3,9	42,00	HW040+NMRV-P110	71C/80A	4	6964
32,3	128	1,0	29,44	HA31+NMRV050	80B	6	3263

## 0,55 kW

n2 [rpm]	M2 [Nm]	fs	i	Gear reducer	Motor		Fr2 [N]
					Size	Pole	
32,3	131	1,8	29,00	HW030+NMRV-P063	80B	6	4244
32,3	131	2,1	29,00	HW030+NMRV-P075	80B	6	5009
31,7	123	0,9	44,17	HA31+NMRV050	71C/80A	4	3283
31,7	125	1,6	44,17	HW030+NMRV-P063	71C/80A	4	4291
31,7	128	2,5	44,17	HW030+NMRV-P075	71C/80A	4	5065
31,3	119	1,5	30,00	NMRV-P063	80B	6	4339
31,3	124	2,3	30,00	NMRV-P075	80B	6	5122
31,3	128	3,8	30,00	NMRV-P090	80B	6	5667
31,3	116	0,8	30,00	NMRV050	80B	6	3320
30,3	140	3,9	31,05	HW040+NMRV-P090	80B	6	5671
30,3	140	3,9	31,05	HW040+NMRV-P110	80B	6	7165
29,6	138	0,9	47,50	HA31+NMRV050	71C/80A	4	3364
29,6	138	1,5	47,50	HW030+NMRV-P063	71C/80A	4	4397
29,6	140	2,2	47,50	HW030+NMRV-P075	71C/80A	4	5190
29,6	138	4,1	46,58	HW040+NMRV-P090	71C	4	5705
28,4	135	2,7	50,00	NMRV-P090	80A	4	5799
28,2	109	0,7	100,00	NMRV-P063	71B	2	4440
28,2	115	1,1	100,00	NMRV-P075	71B	2	5241
27,6	125	1,1	50,00	NMRV-P063	71C/80A	4	4440
27,6	131	1,7	50,00	NMRV-P075	71C/80A	4	5241
26,3	156	0,7	35,63	HA31+NMRV050	80B	6	3477
25,5	158	0,8	54,55	HA31+NMRV050	71C	4	3522
24,5	160	1,3	58,00	HW030+NMRV-P063	71C/80A	4	4699
24,5	165	2,1	58,00	HW030+NMRV-P075	71C/80A	4	5547
24,3	166	1,4	38,67	HW030+NMRV-P063	80B	6	4671
24,3	168	1,9	38,67	HW030+NMRV-P075	80B	6	5513
23,5	142	0,9	60,00	NMRV-P063	71C/80A	4	4719
23,5	149	1,4	60,00	NMRV-P075	71C/80A	4	5569
23,3	156	2,2	60,00	NMRV-P090	80A	4	6163
23,3	165	3,8	60,00	NMRV-P110	80A	4	7787
23,2	147	1,1	40,00	NMRV-P063	80B	6	4776
23,2	154	1,8	40,00	NMRV-P075	80B	6	5637
23,2	161	2,8	40,00	NMRV-P090	80B	6	6238
22,5	182	0,7	63,00	HA31+NMRV050	71C	4	3696
22,5	183	3,4	63,00	HW040+NMRV-P090	71C/80A	4	6309
22,2	187	2,7	42,00	HW040+NMRV-P090	80B	6	6271
22,2	187	2,7	42,00	HW040+NMRV-P110	80B	6	7924
21,2	178	0,7	44,17	HA31+NMRV050	80B	6	3736
21,2	180	1,3	44,17	HW030+NMRV-P063	80B	6	4883
21,2	185	1,4	44,17	HW030+NMRV-P075	80B	6	5763
20,2	203	1,2	47,50	HW030+NMRV-P063	80B	6	5003
20,2	206	1,7	47,50	HW030+NMRV-P075	80B	6	5905

## 0,55 kW

n2 [rpm]	M2 [Nm]	fs	i	Gear reducer	Motor		Fr2 [N]
					Size	Pole	
20,2	200	3,2	46,58	HW040+NMRV-P090	80B	6	6491
20,2	203	3,9	46,58	HW040+NMRV-P110	80B	6	8202
19,4	195	1,2	71,25	HW030+NMRV-P063	71C/80A	4	5033
19,4	201	1,8	71,25	HW030+NMRV-P075	71C/80A	4	5941
19,2	173	0,9	50,00	NMRV-P063	80B	6	5145
19,2	179	1,4	50,00	NMRV-P075	80B	6	6073
19,2	193	2,2	50,00	NMRV-P090	80B	6	6719
19,2	201	3,7	50,00	NMRV-P110	80B	6	8491
18,4	205	1,0	77,33	HW030+NMRV-P063	71C/80A	4	5172
18,4	210	1,7	77,33	HW030+NMRV-P075	71C/80A	4	6105
18,4	213	2,5	77,63	HW040+NMRV-P090	71C/80A	4	6764
18,3	172	0,7	80,00	NMRV-P063	80A	4	5193
18,3	189	1,5	80,00	NMRV-P090	80A	4	6783
18,3	201	2,5	80,00	NMRV-P110	80A	4	8571
17,4	222	1,1	81,82	HW030+NMRV-P063	71C/80A	4	5270
17,4	229	1,7	81,82	HW030+NMRV-P075	71C/80A	4	6221
17,4	183	1,0	80,00	NMRV-P075	71C/80A	4	6130
16,4	210	1,0	88,33	HW030+NMRV-P063	71C/80A	4	5407
16,4	220	1,5	88,33	HW030+NMRV-P075	71C/80A	4	6382
16,4	235	2,6	84,00	HW040+NMRV-P090	71C/80A	4	6944
16,4	241	3,9	84,00	HW040+NMRV-P110	71C/80A	4	8774
16,2	234	1,1	58,00	HW030+NMRV-P063	80B	6	5347
16,2	240	1,2	58,00	HW030+NMRV-P075	80B	6	6311
16,2	198	0,8	60,00	NMRV-P063	80B	6	5467
16,2	208	1,2	60,00	NMRV-P075	80B	6	6453
16,2	218	1,7	60,00	NMRV-P090	80B	6	7140
16,2	232	2,9	60,00	NMRV-P110	80B	6	9023
15,3	242	2,5	93,16	HW040+NMRV-P090	71C/80A	4	7188
15,2	267	2,6	63,00	HW040+NMRV-P090	80B	6	7179
15,2	263	3,9	62,11	HW040+NMRV-P110	80B	6	9028
14,3	248	0,9	95,00	HW030+NMRV-P063	71C/80A	4	5540
14,3	254	1,5	95,00	HW030+NMRV-P075	71C/80A	4	6538
14,3	210	0,8	100,00	NMRV-P075	71C/80A	4	6603
14,2	264	2,2	100,00	NMRV-P050/090	71C/80A	4	6487
14,2	264	2,4	100,00	NMRV-P050/110	71C/80A	4	8198
14,2	222	1,2	100,00	NMRV-P090	80A	4	7306
14,2	237	2,0	100,00	NMRV-P110	80A	4	9232
14,0	247	1,0	100,00	NMRV-P040/063	71C	4	4967
14,0	250	1,4	100,00	NMRV-P040/075	71C	4	5863
14,0	255	1,4	100,00	NMRV-P040/090	71C	4	6487
13,3	282	0,9	109,09	HW030+NMRV-P063	71C/80A	4	5801
13,3	290	1,4	109,09	HW030+NMRV-P075	71C/80A	4	6847

## 0,55 kW

n2 [rpm]	M2 [Nm]	fs	i	Gear reducer	Motor		Fr2 [N]
					Size	Pole	
13,3	294	3,8	105,00	HW040+NMRV-P110	71C/80A	4	9452
13,1	285	0,9	71,25	HW030+NMRV-P063	80B	6	5727
13,1	293	1,0	71,25	HW030+NMRV-P075	80B	6	6759
12,3	317	0,8	118,13	HW030+NMRV-P063	71C/80A	4	5957
12,3	282	1,3	116,00	HW030+NMRV-P075	71C/80A	4	6989
12,3	303	2,1	110,00	HW040+NMRV-P090	71C/80A	4	7597
12,1	296	0,9	77,33	HW030+NMRV-P063	80B	6	5885
12,1	304	1,4	77,33	HW030+NMRV-P075	80B	6	6947
12,1	308	2,0	77,63	HW040+NMRV-P090	80B	6	7696
12,1	321	3,6	77,63	HW040+NMRV-P110	80B	6	9725
12,1	250	0,9	80,00	NMRV-P075	80B	6	7103
12,1	268	1,2	80,00	NMRV-P090	80B	6	7859
12,1	286	2,0	80,00	NMRV-P110	80B	6	9931
11,2	317	2,0	126,00	HW040+NMRV-P090	71C/80A	4	7949
11,2	319	3,7	126,00	HW040+NMRV-P110	71C/80A	4	10044
11,1	301	0,8	88,33	HW030+NMRV-P063	80B	6	6152
11,1	327	0,9	81,82	HW030+NMRV-P063	80B	6	5997
11,1	315	1,3	88,33	HW030+NMRV-P075	80B	6	7261
11,1	335	1,0	81,82	HW030+NMRV-P075	80B	6	7078
11,1	342	2,0	84,00	HW040+NMRV-P090	80B	6	7901
11,1	351	2,7	84,00	HW040+NMRV-P110	80B	6	9984
10,2	325	0,8	142,50	HW030+NMRV-P063	71C/80A	4	6270
10,2	341	1,2	142,50	HW030+NMRV-P075	71C/80A	4	7380
10,2	347	1,0	136,36	HW030+NMRV-P075	71C/80A	4	7376
10,2	364	1,7	137,50	HW040+NMRV-P090	71C/80A	4	8180
10,2	379	2,5	137,50	HW040+NMRV-P110	71C/80A	4	10320
10,1	359	0,7	95,00	HW030+NMRV-P063	80B	6	6270
10,1	370	1,2	95,00	HW030+NMRV-P075	80B	6	7380
10,1	346	2,0	93,16	HW040+NMRV-P090	80B	6	8178
10,1	347	3,6	93,16	HW040+NMRV-P110	80B	6	10320
9,5	377	1,7	150,00	NMRV-P050/090	71C/80A	4	7426
9,5	382	2,4	150,00	NMRV-P050/110	71C/80A	4	9384
9,5	382	3,1	150,00	NMRV-P063/110	71C/80A	4	9384
9,3	346	0,7	150,00	NMRV-P040/063	71C	4	5686
9,3	356	1,2	150,00	NMRV-P040/075	71C	4	6712
9,3	365	1,4	150,00	NMRV-P040/090	71C	4	7426
9,2	347	1,0	154,67	HW030+NMRV-P075	71C/80A	4	7380
9,2	356	1,4	155,26	HW040+NMRV-P090	71C/80A	4	8180
9,2	374	2,5	155,26	HW040+NMRV-P110	71C/80A	4	10320
9,1	364	0,7	163,64	HW030+NMRV-P063	80A	4	6270
9,1	422	1,1	109,09	HW030+NMRV-P075	80B	6	7380
9,1	428	2,7	105,00	HW040+NMRV-P110	80B	6	10320



## 0,55 kW

n2 [rpm]	M2 [Nm]	fs	i	Gear reducer	Motor Size	Pole	Fr2 [N]
9,1	308	0,9	100,00	NMRV-P090	80B	6	8180
9,1	329	1,5	100,00	NMRV-P110	80B	6	10320
8,2	363	0,8	176,67	HW030+NMRV-P075	71C/80A	4	7380
8,2	387	1,1	163,64	HW030+NMRV-P075	71C/80A	4	7380
8,2	408	1,7	165,00	HW040+NMRV-P090	71C/80A	4	8180
8,2	414	2,7	168,00	HW040+NMRV-P110	71C/80A	4	10320
8,1	406	1,1	116,00	HW030+NMRV-P075	80B	6	7380
8,1	444	1,7	110,00	HW040+NMRV-P090	80B	6	8180
7,2	491	0,8	196,88	HW030+NMRV-P075	71C/80A	4	7380
7,2	400	1,1	186,32	HW040+NMRV-P090	71C/80A	4	8180
7,2	428	1,9	186,32	HW040+NMRV-P110	71C/80A	4	10320
7,1	483	1,2	200,00	NMRV-P050/090	71C/80A	4	8174
7,1	496	2,3	200,00	NMRV-P050/110	71C/80A	4	10320
7,1	496	2,3	200,00	NMRV-P063/110	71C/80A	4	10320
7,1	496	3,2	200,00	NMRV-P063/130	71C/80A	4	13500
7,1	493	0,9	142,50	HW030+NMRV-P075	80B	6	7380
7,1	506	0,8	136,36	HW030+NMRV-P075	80B	6	7380
7,1	459	1,7	126,00	HW040+NMRV-P090	80B	6	8180
7,1	533	1,3	137,50	HW040+NMRV-P090	80B	6	8180
7,1	459	2,7	126,00	HW040+NMRV-P110	80B	6	10320
7,1	555	1,7	137,50	HW040+NMRV-P110	80B	6	10320
7,0	449	0,9	200,00	NMRV-P040/075	71C	4	7380
7,0	468	1,3	200,00	NMRV-P040/090	71C	4	8174
6,1	476	0,8	218,18	HW030+NMRV-P075	71C/80A	4	7380
6,1	547	0,9	236,25	HW030+NMRV-P075	71C/80A	4	7380
6,1	504	1,3	220,00	HW040+NMRV-P090	71C/80A	4	8180
6,1	529	2,2	220,00	HW040+NMRV-P110	71C/80A	4	10320
6,1	500	0,8	154,67	HW030+NMRV-P075	80B	6	7380
6,1	563	0,9	163,64	HW030+NMRV-P075	80B	6	7380
6,1	504	1,1	155,26	HW040+NMRV-P090	80B	6	8180
6,1	594	1,4	165,00	HW040+NMRV-P090	80B	6	8180
6,1	534	1,9	155,26	HW040+NMRV-P110	80B	6	10320
6,1	595	2,0	168,00	HW040+NMRV-P110	80B	6	10320
5,7	580	1,0	250,00	NMRV-P050/090	71C/80A	4	8180
5,7	603	1,9	250,00	NMRV-P050/110	71C/80A	4	10320
5,7	603	1,9	250,00	NMRV-P063/110	71C/80A	4	10320
5,7	603	2,5	250,00	NMRV-P063/130	71C/80A	4	13500
5,7	603	3,3	250,00	NMRV-P063/150	71C/80A	4	18000
5,6	562	1,0	250,00	NMRV-P040/090	71C	4	8180
5,1	520	0,9	252,00	HW040+NMRV-P090	71C/80A	4	8180
5,1	591	1,0	275,00	HW040+NMRV-P090	71C/80A	4	8180
5,1	557	1,6	252,00	HW040+NMRV-P110	71C/80A	4	10320

## 0,55 kW

n2 [rpm]	M2 [Nm]	fs	i	Gear reducer	Motor		Fr2 [N]
					Size	Pole	
5,1	629	1,7	275,00	HW040+NMRV-P110	71C/80A	4	10320
5,1	564	0,9	186,32	HW040+NMRV-P090	80B	6	8180
5,1	604	1,5	186,32	HW040+NMRV-P110	80B	6	10320
4,7	647	1,1	300,00	NMRV-P050/090	71C/80A	4	8180
4,7	647	1,9	300,00	NMRV-P050/110	71C/80A	4	10320
4,7	647	1,9	300,00	NMRV-P063/110	71C/80A	4	10320
4,7	657	2,6	300,00	NMRV-P063/130	71C/80A	4	13500
4,7	718	3,2	300,00	NMRV-P063/150	71C/80A	4	18000
4,7	599	0,7	300,00	NMRV-P040/075	71C	4	7380
4,7	627	1,1	300,00	NMRV-P040/090	71C	4	8180
4,6	650	0,8	304,55	HW040+NMRV-P090	71C/80A	4	8180
4,6	693	1,4	304,55	HW040+NMRV-P110	71C/80A	4	10320
4,3	662	0,8	330,00	HW040+NMRV-P090	71C/80A	4	8180
4,3	709	1,3	330,00	HW040+NMRV-P110	71C/80A	4	10320
4,2	732	1,0	220,00	HW040+NMRV-P090	80B	6	8180
4,2	767	1,6	220,00	HW040+NMRV-P110	80B	6	10320
3,7	741	0,7	252,00	HW040+NMRV-P090	80B	6	8180
3,7	796	1,2	252,00	HW040+NMRV-P110	80B	6	10320
3,7	804	0,8	383,33	HW040+NMRV-P090	71C/80A	4	8180
3,7	861	1,1	383,33	HW040+NMRV-P110	71C/80A	4	10320
3,5	798	0,8	400,00	NMRV-P050/090	71C/80A	4	8180
3,5	837	1,4	400,00	NMRV-P050/110	71C/80A	4	10320
3,5	837	1,4	400,00	NMRV-P063/110	71C/80A	4	10320
3,5	837	1,9	400,00	NMRV-P063/130	71C/80A	4	13500
3,5	850	3,1	400,00	NMRV-P063/150	71C/80A	4	18000
3,5	774	0,8	400,00	NMRV-P040/090	71C	4	8180
3,4	854	0,7	275,00	HW040+NMRV-P090	80B	6	8180
3,4	915	1,3	275,00	HW040+NMRV-P110	80B	6	10320
3,2	863	0,9	440,00	HW040+NMRV-P110	71C/80A	4	10320
3,1	1009	1,1	304,55	HW040+NMRV-P110	80B	6	10320
3,1	965	1,0	460,00	HW040+NMRV-P110	71C/80A	4	10320
2,8	1110	1,0	500,00	NMRV-P050/110	71C/80A	4	10320
2,8	1138	1,0	500,00	NMRV-P063/110	71C/80A	4	10320
2,8	998	1,5	500,00	NMRV-P063/130	71C/80A	4	13500
2,8	998	2,3	500,00	NMRV-P063/150	71C/80A	4	18000
2,8	1024	1,0	330,00	HW040+NMRV-P110	80B	6	10320
2,7	1093	0,8	525,00	HW040+NMRV-P110	71C	4	10320
2,4	1260	0,8	383,33	HW040+NMRV-P110	80B	6	10320
2,4	1190	1,0	600,00	NMRV-P050/110	71C/80A	4	10320
2,4	1220	1,0	600,00	NMRV-P063/110	71C/80A	4	10320
2,4	1237	1,4	600,00	NMRV-P063/130	71C/80A	4	13500
2,4	1230	2,1	600,00	NMRV-P063/150	71C/80A	4	18000

## 0,55 kW

n2 [rpm]	M2 [Nm]	fs	i	Gear reducer	Size	Motor Pole	Fr2 [N]
2,0	1405	0,7	460,00	HW040+NMRV-P110	80B	6	10320
1,9	1432	0,9	750,00	NMRV-P050/110	71C/80A	4	10320
1,9	1468	0,8	750,00	NMRV-P063/110	71C/80A	4	10320
1,9	1491	1,2	750,00	NMRV-P063/130	71C/80A	4	13500
1,9	1444	1,6	750,00	NMRV-P063/150	71C/80A	4	18000
1,6	1628	0,8	900,00	NMRV-P050/110	71C/80A	4	10320
1,6	1673	0,7	900,00	NMRV-P063/110	71C/80A	4	10320
1,6	1698	1,0	900,00	NMRV-P063/130	71C/80A	4	13500
1,6	1823	1,1	900,00	NMRV-P063/150	71C/80A	4	18000
1,2	2143	0,8	1200,00	NMRV-P063/130	71C/80A	4	13500
1,2	2198	1,2	1200,00	NMRV-P063/150	71C/80A	4	18000
0,9	2580	0,9	1500,00	NMRV-P063/150	71C/80A	4	18000
0,6	3691	0,7	2400,00	NMRV-P063/150	71C/80A	4	18000

## 0,75 kW

n2 [rpm]	M2 [Nm]	fs	i	Gear reducer	Size	Motor Pole	Fr2 [N]
572,0	12	4,0	5,00	NMRV050	80A	2	1251
381,0	17	3,1	7,50	NMRV050	80A	2	1433
288,0	22	3,1	5,00	NMRV050	80B	4	1577
286,0	23	2,4	10,00	NMRV050	80A	2	1577
192,3	33	3,8	7,50	NMRV-P063	80B	4	2359
192,3	33	2,4	7,50	NMRV050	80B	4	1805
191,0	33	3,3	15,00	NMRV-P063	80A	2	2359
190,3	33	1,8	15,00	NMRV050	80A	2	1805
144,0	44	3,1	10,00	NMRV-P063	80B	4	2597
144,0	44	1,9	10,00	NMRV050	80B	4	1987
143,5	43	4,0	20,00	NMRV-P075	80A	2	3065
143,0	43	2,4	20,00	NMRV-P063	80A	2	2597
143,0	42	1,3	20,00	NMRV050	80A	2	1987
125,0	50	3,0	7,50	NMRV-P063	90S	6	2734
114,0	52	1,8	25,00	NMRV-P063	80A	2	2797
114,0	53	3,1	25,00	NMRV-P075	80A	2	3302
114,0	51	1,0	25,00	NMRV050	80A	2	2140
96,0	63	2,4	15,00	NMRV-P063	80B	4	2973
95,7	60	2,0	30,00	NMRV-P063	80A	2	2973
95,7	65	3,6	15,00	NMRV-P075	80B	4	3509
95,7	62	1,3	15,00	NMRV050	80B	4	2274
95,0	61	3,0	30,00	NMRV-P075	80A	2	3509
95,0	58	1,1	30,00	NMRV050	80A	2	2274
94,0	65	2,4	10,00	NMRV-P063	90S	6	3009
94,0	66	3,5	10,00	NMRV-P075	90S	6	3551

## 0,75 kW

n2 [rpm]	M2 [Nm]	fs	i	Gear reducer	Size	Motor Pole	Fr2 [N]
72,0	82	1,8	20,00	NMRV-P063	80B	4	3272
72,0	83	2,9	20,00	NMRV-P075	80B	4	3862
72,0	80	1,0	20,00	NMRV050	80B	4	2503
71,5	76	1,5	40,00	NMRV-P063	80A	2	3272
71,2	79	2,3	40,00	NMRV-P075	80A	2	3862
71,2	81	3,5	40,00	NMRV-P090	80A	2	4273
64,8	89	1,1	22,08	HA31+NMRV050	80B	4	2587
64,8	91	2,1	22,08	HW030+NMRV-P063	80B	4	3382
64,8	90	2,9	22,08	HW030+NMRV-P075	80B	4	3991
63,0	94	1,8	15,00	NMRV-P063	90S	6	3444
63,0	95	2,8	15,00	NMRV-P075	90S	6	4065
60,4	96	0,7	23,75	HA31+NMRV050	80B	4	2632
58,0	96	0,7	25,00	NMRV050	80B	4	2696
57,6	101	2,2	25,00	NMRV-P075	80B	4	4160
57,4	94	1,7	50,00	NMRV-P075	80A	2	4160
57,4	96	2,7	50,00	NMRV-P090	80A	2	4603
57,4	98	1,4	25,00	NMRV-P063	80B	4	3524
57,4	103	3,6	25,00	NMRV-P090	80B	4	4603
57,0	90	1,1	50,00	NMRV-P063	80A	2	3524
50,0	118	2,4	29,00	HW030+NMRV-P075	80B	4	4330
49,4	119	1,7	29,00	HW030+NMRV-P063	80B	4	3703
49,3	116	1,0	29,44	HA31+NMRV050	80B	4	2827
48,3	112	1,4	30,00	NMRV-P063	80B	4	3745
48,3	115	2,1	30,00	NMRV-P075	80B	4	4421
48,3	118	3,6	30,00	NMRV-P090	80B	4	4891
48,3	109	0,8	30,00	NMRV050	80B	4	2865
48,0	113	2,2	60,00	NMRV-P090	80A	2	4891
47,8	104	0,9	60,00	NMRV-P063	80A	2	3745
47,8	117	4,1	60,00	NMRV-P110	80A	2	6181
47,3	108	1,5	60,00	NMRV-P075	80A	2	4421
47,0	119	1,4	20,00	NMRV-P063	90S	6	3791
47,0	122	2,2	20,00	NMRV-P075	90S	6	4474
47,0	125	3,5	20,00	NMRV-P090	90S	6	4951
46,0	127	3,9	31,05	HW040+NMRV-P090	80B	4	4902
40,3	141	0,7	35,63	HA31+NMRV050	80B	4	3013
40,0	146	2,9	23,29	HW040+NMRV-P090	90S	6	5134
40,0	146	2,9	23,29	HW040+NMRV-P110	90S	6	6487
38,0	145	1,0	25,00	NMRV-P063	90S	6	4084
38,0	149	1,6	25,00	NMRV-P075	90S	6	4820
37,8	153	2,7	25,00	NMRV-P090	90S	6	5333
37,0	151	1,3	38,67	HW030+NMRV-P063	80B	4	4076
37,0	153	2,0	38,67	HW030+NMRV-P075	80B	4	4811

## 0,75 kW

n2 [rpm]	M2 [Nm]	fs	i	Gear reducer	Size	Motor Pole	Fr2 [N]
36,3	141	1,0	40,00	NMRV-P063	80B	4	4122
36,0	145	1,7	40,00	NMRV-P075	80B	4	4865
36,0	152	2,6	40,00	NMRV-P090	80B	4	5383
35,6	135	1,0	80,00	NMRV-P075	80A	2	4865
35,6	141	1,6	80,00	NMRV-P090	80A	2	5383
35,6	148	2,6	80,00	NMRV-P110	80A	2	6803
33,9	169	2,9	42,00	HW040+NMRV-P090	80B	4	5472
33,9	169	2,9	42,00	HW040+NMRV-P110	80B	4	6914
33,0	163	0,7	44,17	HA31+NMRV050	80B	4	3229
33,0	166	1,2	44,17	HW030+NMRV-P063	80B	4	4221
32,9	170	1,9	44,17	HW030+NMRV-P075	80B	4	5029
31,7	162	1,1	30,00	NMRV-P063	90S	6	4339
31,7	169	1,6	30,00	NMRV-P075	90S	6	5122
31,7	174	2,8	30,00	NMRV-P090	90S	6	5667
31,0	183	3,1	46,58	HW040+NMRV-P090	80B	4	5611
30,2	184	0,7	47,50	HA31+NMRV050	80B	4	3316
30,2	184	1,2	47,50	HW030+NMRV-P063	80B	4	4334
30,0	186	1,7	47,50	HW030+NMRV-P075	80B	4	5104
30,0	190	2,9	31,05	HW040+NMRV-P090	90S	6	5650
30,0	190	2,9	31,05	HW040+NMRV-P110	90S	6	7140
29,0	167	0,9	50,00	NMRV-P063	80B	4	4440
29,0	182	2,1	50,00	NMRV-P090	80B	4	5799
29,0	189	3,5	50,00	NMRV-P110	80B	4	7328
28,8	174	1,3	50,00	NMRV-P075	80B	4	5241
28,5	155	0,8	100,00	NMRV-P075	80A	2	5241
28,5	165	1,2	100,00	NMRV-P090	80A	2	5799
28,2	176	2,1	100,00	NMRV-P110	80A	2	7328
25,2	214	1,0	58,00	HW030+NMRV-P063	80B	4	4633
25,0	219	1,6	58,00	HW030+NMRV-P075	80B	4	5455
24,0	188	0,7	60,00	NMRV-P063	80B	4	4719
24,0	221	2,8	60,00	NMRV-P110	80B	4	7787
23,7	241	3,8	62,11	HW040+NMRV-P110	80B	4	7877
23,7	197	1,1	60,00	NMRV-P075	80B	4	5569
23,7	209	1,6	60,00	NMRV-P090	80B	4	6163
23,5	202	0,8	40,00	NMRV-P063	90S	6	4776
23,5	210	1,3	40,00	NMRV-P075	90S	6	5637
23,5	219	2,0	40,00	NMRV-P090	90S	6	6238
23,5	229	3,5	40,00	NMRV-P110	90S	6	7882
23,2	242	2,5	63,00	HW040+NMRV-P090	80B	4	6219
22,5	255	1,9	42,00	HW040+NMRV-P090	90S	6	6294
22,5	255	1,9	42,00	HW040+NMRV-P110	90S	6	7953
20,4	273	2,3	46,58	HW040+NMRV-P090	90S	6	6515

## 0,75 kW

n2 [rpm]	M2 [Nm]	fs	i	Gear reducer	Motor Size	Pole	Fr2 [N]
20,1	259	0,9	71,25	HW030+NMRV-P063	80B	4	4962
20,0	266	1,4	71,25	HW030+NMRV-P075	80B	4	5843
20,0	276	2,9	46,58	HW040+NMRV-P110	90S	6	8173
19,0	244	1,0	50,00	NMRV-P075	90S	6	6073
18,5	271	0,8	77,33	HW030+NMRV-P063	80B	4	5135
18,5	294	3,3	77,63	HW040+NMRV-P110	80B	4	8485
18,5	243	0,8	80,00	NMRV-P075	80B	4	6130
18,4	263	1,6	50,00	NMRV-P090	90S	6	6719
18,4	274	2,8	50,00	NMRV-P110	90S	6	8491
18,1	279	1,3	77,33	HW030+NMRV-P075	80B	4	6018
18,1	282	1,8	77,63	HW040+NMRV-P090	80B	4	6668
18,0	255	1,1	80,00	NMRV-P090	80B	4	6783
18,0	271	1,9	80,00	NMRV-P110	80B	4	8571
17,5	296	0,8	81,82	HW030+NMRV-P063	80B	4	5233
17,5	303	1,3	81,82	HW030+NMRV-P075	80B	4	6176
17,5	311	1,9	84,00	HW040+NMRV-P090	80B	4	6894
17,1	320	2,9	84,00	HW040+NMRV-P110	80B	4	8650
16,5	293	1,1	88,33	HW030+NMRV-P075	80B	4	6336
16,0	280	0,8	88,33	HW030+NMRV-P063	80B	4	5318
15,3	364	1,9	63,00	HW040+NMRV-P090	90S	6	7204
15,3	359	3,0	62,11	HW040+NMRV-P110	90S	6	9060
15,3	284	0,9	60,00	NMRV-P075	90S	6	6453
15,3	298	1,3	60,00	NMRV-P090	90S	6	7140
15,3	315	2,1	60,00	NMRV-P110	90S	6	9023
15,1	338	1,2	95,00	HW030+NMRV-P075	80B	4	6446
15,0	328	0,7	95,00	HW030+NMRV-P063	80B	4	5448
15,0	320	1,9	93,16	HW040+NMRV-P090	80B	4	7069
15,0	324	3,2	93,16	HW040+NMRV-P110	80B	4	8933
14,4	365	1,6	100,00	NMRV-P050/090	80B	4	6487
14,4	365	1,8	100,00	NMRV-P050/110	80B	4	8198
14,4	365	3,0	100,00	NMRV-P063/110	80B	4	8198
14,4	369	3,0	100,00	NMRV-P063/130	80B	4	10722
14,1	389	2,8	105,00	HW040+NMRV-P110	80B	4	9318
14,1	299	0,9	100,00	NMRV-P090	80B	4	7306
14,1	319	1,5	100,00	NMRV-P110	80B	4	9232
13,1	384	1,1	109,09	HW030+NMRV-P075	80B	4	6750
13,1	402	1,6	110,00	HW040+NMRV-P090	80B	4	7489
12,3	438	2,7	77,63	HW040+NMRV-P110	90S	6	9760
12,3	366	0,8	80,00	NMRV-P090	90S	6	7859
12,3	391	1,4	80,00	NMRV-P110	90S	6	9931
12,3	396	2,1	80,00	NMRV130	90S	6	12989
12,1	373	1,0	116,00	HW030+NMRV-P075	80B	4	6889

## 0,75 kW

n2 [rpm]	M2 [Nm]	fs	i	Gear reducer	Size	Motor Pole	Fr2 [N]
12,0	420	1,5	77,63	HW040+NMRV-P090	90S	6	7669
11,2	480	1,9	84,00	HW040+NMRV-P110	90S	6	10020
11,1	421	1,6	126,00	HW040+NMRV-P090	80B	4	7836
11,0	460	0,8	136,36	HW030+NMRV-P075	80B	4	7254
11,0	467	1,5	84,00	HW040+NMRV-P090	90S	6	7873
11,0	424	2,8	126,00	HW040+NMRV-P110	80B	4	9879
10,3	451	0,9	142,50	HW030+NMRV-P075	80B	4	7380
10,3	503	1,9	137,50	HW040+NMRV-P110	80B	4	10266
10,1	483	1,3	137,50	HW040+NMRV-P090	80B	4	8068
10,0	472	1,5	93,16	HW040+NMRV-P090	90S	6	8149
10,0	474	2,6	93,16	HW040+NMRV-P110	90S	6	10297
9,6	521	1,3	150,00	NMRV-P050/090	80B	4	7426
9,6	527	1,8	150,00	NMRV-P050/110	80B	4	9384
9,6	527	2,3	150,00	NMRV-P063/110	80B	4	9384
9,6	521	3,0	150,00	NMRV-P063/130	80B	4	12274
9,6	526	3,7	150,00	NMRV-P063/150	80B	4	18000
9,3	461	0,8	154,67	HW030+NMRV-P075	80B	4	7380
9,3	473	1,1	155,26	HW040+NMRV-P090	80B	4	8180
9,2	457	1,7	100,00	NMRV130	90S	6	13500
9,0	513	0,8	163,64	HW030+NMRV-P075	80B	4	7380
9,0	606	1,2	110,00	HW040+NMRV-P090	90S	6	8180
9,0	541	1,3	165,00	HW040+NMRV-P090	80B	4	8180
9,0	496	1,9	155,26	HW040+NMRV-P110	80B	4	10320
9,0	584	2,0	105,00	HW040+NMRV-P110	90S	6	10320
9,0	450	1,1	100,00	NMRV-P110	90S	6	10320
8,2	567	1,4	186,32	HW040+NMRV-P110	80B	4	10320
8,2	548	2,0	168,00	HW040+NMRV-P110	80B	4	10320
8,0	531	0,9	186,32	HW040+NMRV-P090	80B	4	8180
7,2	668	0,9	200,00	NMRV-P050/090	80B	4	8174
7,2	685	1,7	200,00	NMRV-P050/110	80B	4	10320
7,2	685	1,7	200,00	NMRV-P063/110	80B	4	10320
7,2	685	2,3	200,00	NMRV-P063/130	80B	4	13500
7,2	685	3,0	200,00	NMRV-P063/150	80B	4	18000
7,2	626	1,2	126,00	HW040+NMRV-P090	90S	6	8180
7,2	727	0,9	137,50	HW040+NMRV-P090	90S	6	8180
7,2	758	1,3	137,50	HW040+NMRV-P110	90S	6	10320
7,0	668	1,0	220,00	HW040+NMRV-P090	80B	4	8180
7,0	627	2,0	126,00	HW040+NMRV-P110	90S	6	10320
7,0	702	1,7	220,00	HW040+NMRV-P110	80B	4	10320
6,2	689	0,7	252,00	HW040+NMRV-P090	80B	4	8180
6,1	686	0,8	155,26	HW040+NMRV-P090	90S	6	8180
6,1	729	1,4	155,26	HW040+NMRV-P110	90S	6	10320

## 0,75 kW

n2 [rpm]	M2 [Nm]	fs	i	Gear reducer	Size	Motor Pole	Fr2 [N]
6,0	810	1,0	165,00	HW040+NMRV-P090	90S	6	8180
6,0	811	1,5	168,00	HW040+NMRV-P110	90S	6	10320
6,0	738	1,2	252,00	HW040+NMRV-P110	80B	4	10320
5,8	801	0,7	250,00	NMRV-P050/090	80B	4	8180
5,8	835	1,4	250,00	NMRV-P050/110	80B	4	10320
5,8	835	1,4	250,00	NMRV-P063/110	80B	4	10320
5,8	835	1,8	250,00	NMRV-P063/130	80B	4	13500
5,8	835	2,5	250,00	NMRV-P063/150	80B	4	18000
5,0	785	0,8	275,00	HW040+NMRV-P090	80B	4	8180
5,0	835	1,3	275,00	HW040+NMRV-P110	80B	4	10320
5,0	823	1,1	186,32	HW040+NMRV-P110	90S	6	10320
4,8	895	0,8	300,00	NMRV-P050/090	80B	4	8180
4,8	895	1,4	300,00	NMRV-P050/110	80B	4	10320
4,8	895	1,4	300,00	NMRV-P063/110	80B	4	10320
4,8	908	1,9	300,00	NMRV-P063/130	80B	4	13500
4,8	993	2,3	300,00	NMRV-P063/150	80B	4	18000
4,7	919	1,0	304,55	HW040+NMRV-P110	80B	4	10320
4,3	941	1,0	330,00	HW040+NMRV-P110	80B	4	10320
4,3	998	0,8	220,00	HW040+NMRV-P090	90S	6	8180
4,3	1045	1,2	220,00	HW040+NMRV-P110	90S	6	10320
3,8	1141	0,8	383,33	HW040+NMRV-P110	80B	4	10320
3,7	1086	0,9	252,00	HW040+NMRV-P110	90S	6	10320
3,6	1157	1,0	400,00	NMRV-P050/110	80B	4	10320
3,6	1157	1,0	400,00	NMRV-P063/110	80B	4	10320
3,6	1157	1,4	400,00	NMRV-P063/130	80B	4	13500
3,6	1175	2,3	400,00	NMRV-P063/150	80B	4	18000
3,4	1248	0,9	275,00	HW040+NMRV-P110	90S	6	10320
3,1	1280	0,8	460,00	HW040+NMRV-P110	80B	4	10320
3,1	1376	0,8	304,55	HW040+NMRV-P110	90S	6	10320
2,9	1535	0,8	500,00	NMRV-P050/110	80B	4	10320
2,9	1573	0,7	500,00	NMRV-P063/110	80B	4	10320
2,9	1380	1,1	500,00	NMRV-P063/130	80B	4	13500
2,9	1380	1,7	500,00	NMRV-P063/150	80B	4	18000
2,8	1397	0,7	330,00	HW040+NMRV-P110	90S	6	10320
2,4	1645	0,8	600,00	NMRV-P050/110	80B	4	10320
2,4	1686	0,8	600,00	NMRV-P063/110	80B	4	10320
2,4	1712	1,0	600,00	NMRV-P063/130	80B	4	13500
2,4	1702	1,6	600,00	NMRV-P063/150	80B	4	18000
1,9	2061	0,9	750,00	NMRV-P063/130	80B	4	13500
1,9	1998	1,2	750,00	NMRV-P063/150	80B	4	18000
1,6	2348	0,7	900,00	NMRV-P063/130	80B	4	13500
1,6	2521	0,8	900,00	NMRV-P063/150	80B	4	18000



## 0,75 kW

n2 [rpm]	M2 [Nm]	fs	i	Gear reducer	Size	Motor Pole	Fr2 [N]
1,2	3039	0,9	1200,00	NMRV-P063/150	80B	4	18000

## 1,10 kW

n2 [rpm]	M2 [Nm]	fs	i	Gear reducer	Size	Motor Pole	Fr2 [N]
572,0	17	2,7	5,00	NMRV050	80B	2	1251
381,0	25	3,7	7,50	NMRV-P063	80B	2	1873
381,0	25	2,1	7,50	NMRV050	80B	2	1433
286,0	33	3,0	10,00	NMRV-P063	80B	2	2061
286,0	33	1,7	10,00	NMRV050	80B	2	1577
191,0	49	2,6	7,50	NMRV-P063	90S	4	2359
191,0	48	2,3	15,00	NMRV-P063	80B	2	2359
191,0	49	3,8	7,50	NMRV-P075	90S	4	2785
190,3	49	3,4	15,00	NMRV-P075	80B	2	2785
190,3	48	1,2	15,00	NMRV050	80B	2	1805
143,5	61	0,9	20,00	NMRV050	80B	2	1987
143,0	64	2,1	10,00	NMRV-P063	90S	4	2597
143,0	63	1,7	20,00	NMRV-P063	80B	2	2597
143,0	65	3,1	10,00	NMRV-P075	90S	4	3065
143,0	64	2,7	20,00	NMRV-P075	80B	2	3065
143,0	65	4,0	20,00	NMRV-P090	80B	2	3391
127,0	73	2,9	7,50	NMRV-P075	100LR	6	3227
114,8	76	1,2	25,00	NMRV-P063	80B	2	2797
114,8	77	2,0	25,00	NMRV-P075	80B	2	3302
114,8	79	3,1	25,00	NMRV-P090	80B	2	3653
95,7	87	1,4	30,00	NMRV-P063	80B	2	2973
95,7	89	2,1	30,00	NMRV-P075	80B	2	3509
95,7	91	3,4	30,00	NMRV-P090	80B	2	3882
95,0	95	2,4	10,00	NMRV-P075	100LR	6	3551
95,0	95	2,4	15,00	NMRV-P075	90S	4	3509
95,0	85	0,7	30,00	NMRV050	80B	2	2274
95,0	93	1,6	15,00	NMRV-P063	90S	4	2973
72,0	112	1,0	40,00	NMRV-P063	80B	2	3272
72,0	115	1,6	40,00	NMRV-P075	80B	2	3862
72,0	118	2,3	40,00	NMRV-P090	80B	2	4273
71,5	120	1,2	20,00	NMRV-P063	90S	4	3272
71,5	122	1,9	20,00	NMRV-P075	90S	4	3862
71,5	125	3,2	20,00	NMRV-P090	90S	4	4273
63,0	138	1,9	15,00	NMRV-P075	100LR	6	4065
63,0	141	3,3	15,00	NMRV-P090	100LR	6	4498
61,0	142	2,9	23,29	HW040+NMRV-P090	90S	4	4464
61,0	144	2,9	23,29	HW040+NMRV-P110	90S	4	5640

## 1,10 kW

n2 [rpm]	M2 [Nm]	fs	i	Gear reducer	Motor		Fr2 [N]
					Size	Pole	
57,6	133	0,8	50,00	NMRV-P063	80B	2	3524
57,6	142	1,9	50,00	NMRV-P090	80B	2	4603
57,4	138	1,2	50,00	NMRV-P075	80B	2	4160
57,2	153	2,5	25,00	NMRV-P090	90S	4	4603
57,0	145	0,9	25,00	NMRV-P063	90S	4	3524
57,0	149	1,4	25,00	NMRV-P075	90S	4	4160
57,0	147	3,4	50,00	NMRV-P110	80B	2	5816
48,0	165	0,9	30,00	NMRV-P063	90S	4	3745
48,0	174	2,5	30,00	NMRV-P090	90S	4	4891
48,0	177	1,5	20,00	NMRV-P075	100LR	6	4474
48,0	170	1,5	30,00	NMRV-P075	90S	4	4421
48,0	159	1,0	60,00	NMRV-P075	80B	2	4421
48,0	181	2,4	20,00	NMRV-P090	100LR	6	4951
48,0	186	3,9	20,00	NMRV-P110	100LR	6	6256
47,5	165	1,5	60,00	NMRV-P090	80B	2	4891
47,5	172	2,7	60,00	NMRV-P110	80B	2	6181
46,0	187	2,7	31,05	HW040+NMRV-P090	90S	4	4913
46,0	187	2,9	31,05	HW040+NMRV-P110	90S	4	6208
38,0	216	1,1	25,00	NMRV-P075	100LR	6	4820
38,0	221	1,8	25,00	NMRV-P090	100LR	6	5333
38,0	227	3,3	25,00	NMRV-P110	100LR	6	6739
36,0	209	0,7	40,00	NMRV-P063	90S	4	4122
36,0	215	1,1	40,00	NMRV-P075	90S	4	4865
36,0	197	0,7	80,00	NMRV-P075	80B	2	4865
36,0	206	1,1	80,00	NMRV-P090	80B	2	5383
35,8	223	1,7	40,00	NMRV-P090	90S	4	5383
35,8	232	3,1	40,00	NMRV-P110	90S	4	6803
35,4	218	1,8	80,00	NMRV-P110	80B	2	6803
33,7	250	1,9	42,00	HW040+NMRV-P090	90S	4	5472
33,7	250	1,9	42,00	HW040+NMRV-P110	90S	4	6914
32,0	245	1,2	30,00	NMRV-P075	100LR	6	5122
32,0	252	1,9	30,00	NMRV-P090	100LR	6	5667
32,0	255	3,3	30,00	NMRV-P110	100LR	6	7161
30,6	270	2,0	46,58	HW040+NMRV-P090	90S	4	5664
30,6	273	2,9	46,58	HW040+NMRV-P110	90S	4	7157
28,6	257	0,9	50,00	NMRV-P075	90S	4	5241
28,6	268	1,4	50,00	NMRV-P090	90S	4	5799
28,6	279	2,3	50,00	NMRV-P110	90S	4	7328
28,3	242	0,8	100,00	NMRV-P090	80B	2	5799
28,3	257	1,4	100,00	NMRV-P110	80B	2	7328
24,0	305	0,9	40,00	NMRV-P075	100LR	6	5637
24,0	291	0,7	60,00	NMRV-P075	90S	4	5569

## 1,10 kW

n2 [rpm]	M2 [Nm]	fs	i	Gear reducer	Motor		Fr2 [N]
					Size	Pole	
24,0	318	1,4	40,00	NMRV-P090	100LR	6	6238
24,0	309	1,1	60,00	NMRV-P090	90S	4	6163
24,0	332	2,4	40,00	NMRV-P110	100LR	6	7882
24,0	336	3,3	40,00	NMRV130	100LR	6	10309
23,5	326	1,8	60,00	NMRV-P110	90S	4	7787
23,0	356	2,5	62,11	HW040+NMRV-P110	90S	4	7822
22,5	358	1,7	63,00	HW040+NMRV-P090	90S	4	6264
19,0	354	0,7	50,00	NMRV-P075	100LR	6	6073
19,0	381	1,1	50,00	NMRV-P090	100LR	6	6719
19,0	398	1,9	50,00	NMRV-P110	100LR	6	8491
19,0	404	2,6	50,00	NMRV130	100LR	6	11105
19,0	409	3,9	50,00	NMRV150	100LR	6	15182
18,4	417	1,2	77,63	HW040+NMRV-P090	90S	4	6715
18,4	434	2,2	77,63	HW040+NMRV-P110	90S	4	8485
18,0	376	0,8	80,00	NMRV-P090	90S	4	6783
18,0	400	1,3	80,00	NMRV-P110	90S	4	8571
18,0	406	2,1	80,00	NMRV130	90S	4	11210
17,0	460	1,3	84,00	HW040+NMRV-P090	90S	4	6845
17,0	472	2,0	84,00	HW040+NMRV-P110	90S	4	8650
16,0	431	0,9	60,00	NMRV-P090	100LR	6	7140
16,0	458	1,5	60,00	NMRV-P110	100LR	6	9023
16,0	464	2,0	60,00	NMRV130	100LR	6	11801
16,0	471	3,1	60,00	NMRV150	100LR	6	16133
15,0	473	1,3	93,16	HW040+NMRV-P090	90S	4	7086
15,0	478	2,2	93,16	HW040+NMRV-P110	90S	4	8953
14,3	535	2,1	100,00	NMRV-P063/110	90S	4	8198
14,3	542	2,1	100,00	NMRV-P063/130	90S	4	10722
14,0	470	1,0	100,00	NMRV-P110	90S	4	9232
14,0	478	1,5	100,00	NMRV130	90S	4	12076
13,3	575	1,9	105,00	HW040+NMRV-P110	90S	4	9384
13,0	594	1,1	110,00	HW040+NMRV-P090	90S	4	7489
12,0	566	1,0	80,00	NMRV-P110	100LR	6	9931
12,0	575	1,5	80,00	NMRV130	100LR	6	12989
12,0	584	2,2	80,00	NMRV150	100LR	6	17757
11,0	622	1,1	126,00	HW040+NMRV-P090	90S	4	7836
11,0	626	1,9	126,00	HW040+NMRV-P110	90S	4	9902
10,2	742	1,2	137,50	HW040+NMRV-P110	90S	4	10266
10,0	713	0,9	137,50	HW040+NMRV-P090	90S	4	8068
10,0	652	0,8	100,00	NMRV-P110	100LR	6	10320
10,0	663	1,2	100,00	NMRV130	100LR	6	13500
10,0	675	1,7	100,00	NMRV150	100LR	6	18000
9,5	774	1,5	150,00	NMRV-P063/110	90S	4	9384

## 1,10 kW

n2 [rpm]	M2 [Nm]	fs	i	Gear reducer	Size	Motor Pole	Fr2 [N]
9,5	764	2,1	150,00	NMRV-P063/130	90S	4	12274
9,5	771	2,6	150,00	NMRV-P063/150	90S	4	18000
9,2	697	0,7	155,26	HWO40+NMRV-P090	90S	4	8180
9,2	732	1,2	155,26	HWO40+NMRV-P110	90S	4	10320
9,0	810	1,4	168,00	HWO40+NMRV-P110	90S	4	10320
8,2	799	0,9	165,00	HWO40+NMRV-P090	90S	4	8180
8,2	837	1,0	186,32	HWO40+NMRV-P110	90S	4	10320
7,2	1005	1,1	200,00	NMRV-P063/110	90S	4	10320
7,2	1005	1,6	200,00	NMRV-P063/130	90S	4	13500
7,2	1005	2,1	200,00	NMRV-P063/150	90S	4	18000
7,0	1036	1,1	220,00	HWO40+NMRV-P110	90S	4	10320
6,1	1090	0,8	252,00	HWO40+NMRV-P110	90S	4	10320
5,7	1224	1,0	250,00	NMRV-P063/110	90S	4	10320
5,7	1224	1,2	250,00	NMRV-P063/130	90S	4	13500
5,7	1224	1,7	250,00	NMRV-P063/150	90S	4	18000
5,0	1233	0,9	275,00	HWO40+NMRV-P110	90S	4	10320
4,8	1312	1,0	300,00	NMRV-P063/110	90S	4	10320
4,8	1332	1,3	300,00	NMRV-P063/130	90S	4	13500
4,8	1456	1,6	300,00	NMRV-P063/150	90S	4	18000
4,7	1356	0,7	304,55	HWO40+NMRV-P110	90S	4	10320
3,6	1697	1,0	400,00	NMRV-P063/130	90S	4	13500
3,6	1723	1,5	400,00	NMRV-P063/150	90S	4	18000
2,9	2024	0,8	500,00	NMRV-P063/130	90S	4	13500
2,9	2024	1,2	500,00	NMRV-P063/150	90S	4	18000
2,4	2510	0,7	600,00	NMRV-P063/130	90S	4	13500
2,4	2496	1,1	600,00	NMRV-P063/150	90S	4	18000
1,9	2931	0,8	750,00	NMRV-P063/150	90S	4	18000

## 1,50 kW

n2 [rpm]	M2 [Nm]	fs	i	Gear reducer	Size	Motor Pole	Fr2 [N]
381,7	34	2,8	7,50	NMRV-P063	90S	2	1873
381,7	34	3,8	7,50	NMRV-P075	90S	2	2210
286,0	45	2,2	10,00	NMRV-P063	90S	2	2061
286,0	45	3,4	10,00	NMRV-P075	90S	2	2433
191,0	67	1,9	7,50	NMRV-P063	90L	4	2359
191,0	67	2,8	7,50	NMRV-P075	90L	4	2785
190,3	66	1,7	15,00	NMRV-P063	90S	2	2359
190,3	67	2,5	15,00	NMRV-P075	90S	2	2785
143,0	87	1,5	10,00	NMRV-P063	90L	4	2597
143,0	85	1,2	20,00	NMRV-P063	90S	2	2597
143,0	88	2,3	10,00	NMRV-P075	90L	4	3065

## 1,50 kW

n <sub>2</sub> [rpm]	M <sub>2</sub> [Nm]	f <sub>s</sub>	i	Gear reducer	Motor		Fr <sub>2</sub> [N]
					Size	Pole	
143,0	86	2,0	20,00	NMRV-P075	90S	2	3065
143,0	89	3,8	10,00	NMRV-P090	90L	4	3391
143,0	88	2,9	20,00	NMRV-P090	90S	2	3391
125,0	101	2,1	7,50	NMRV-P075	100L	6	3227
125,0	102	3,7	7,50	NMRV-P090	100L	6	3570
114,6	104	0,9	25,00	NMRV-P063	90S	2	2797
114,6	105	1,5	25,00	NMRV-P075	90S	2	3302
114,0	108	2,3	25,00	NMRV-P090	90S	2	3653
95,7	119	1,0	30,00	NMRV-P063	90S	2	2973
95,7	122	1,5	30,00	NMRV-P075	90S	2	3509
95,7	125	2,5	30,00	NMRV-P090	90S	2	3882
95,0	126	1,2	15,00	NMRV-P063	90L	4	2973
95,0	129	1,7	15,00	NMRV-P075	90L	4	3509
95,0	131	3,1	15,00	NMRV-P090	90L	4	3882
94,0	131	1,8	10,00	NMRV-P075	100L	6	3551
94,0	133	3,1	10,00	NMRV-P090	100L	6	3929
71,7	153	0,7	40,00	NMRV-P063	90S	2	3272
71,7	157	1,2	40,00	NMRV-P075	90S	2	3862
71,7	161	1,7	40,00	NMRV-P090	90S	2	4273
71,7	167	3,2	40,00	NMRV-P110	90S	2	5399
71,5	164	0,9	20,00	NMRV-P063	90L	4	3272
71,5	166	1,4	20,00	NMRV-P075	90L	4	3862
71,5	170	2,2	20,00	NMRV-P090	90L	4	4273
71,5	173	3,7	20,00	NMRV-P110	90L	4	5399
63,0	190	1,4	15,00	NMRV-P075	100L	6	4065
63,0	194	2,4	15,00	NMRV-P090	100L	6	4498
63,0	197	3,9	15,00	NMRV-P110	100L	6	5684
61,0	194	2,1	23,29	HW040+NMRV-P090	90L	4	4464
61,0	196	2,1	23,29	HW040+NMRV-P110	90L	4	5640
57,0	203	1,1	25,00	NMRV-P075	90L	4	4160
57,0	188	0,9	50,00	NMRV-P075	90S	2	4160
57,0	208	1,8	25,00	NMRV-P090	90L	4	4603
57,0	193	1,4	50,00	NMRV-P090	90S	2	4603
57,0	213	3,2	25,00	NMRV-P110	90L	4	5816
56,8	201	2,5	50,00	NMRV-P110	90S	2	5816
48,0	238	1,8	30,00	NMRV-P090	90L	4	4891
48,0	241	3,1	30,00	NMRV-P110	90L	4	6181
47,8	217	0,7	60,00	NMRV-P075	90S	2	4421
47,8	226	1,1	60,00	NMRV-P090	90S	2	4891
47,8	235	2,0	60,00	NMRV-P110	90S	2	6181
47,5	250	1,7	20,00	NMRV-P090	100L	6	4951
47,5	256	2,8	20,00	NMRV-P110	100L	6	6256

## 1,50 kW

n2 [rpm]	M2 [Nm]	fs	i	Gear reducer	Motor Size	Pole	Fr2 [N]
47,3	225	0,7	30,00	NMRV-P063	90L	4	3745
47,3	231	1,1	30,00	NMRV-P075	90L	4	4421
47,0	244	1,1	20,00	NMRV-P075	100L	6	4474
46,3	255	1,9	31,05	HW040+NMRV-P090	90L	4	4924
46,3	255	2,1	31,05	HW040+NMRV-P110	90L	4	6222
38,0	297	0,8	25,00	NMRV-P075	100L	6	4820
38,0	305	1,3	25,00	NMRV-P090	100L	6	5333
37,4	313	2,4	25,00	NMRV-P110	100L	6	6739
37,4	317	3,3	25,00	NMRV130	100L	6	8814
36,0	293	0,8	40,00	NMRV-P075	90L	4	4865
36,0	305	1,3	40,00	NMRV-P090	90L	4	5383
36,0	317	2,2	40,00	NMRV-P110	90L	4	6803
36,0	297	1,3	80,00	NMRV-P110	90S	2	6803
35,9	281	0,8	80,00	NMRV-P090	90S	2	5383
34,0	340	1,4	42,00	HW040+NMRV-P090	90L	4	5433
34,0	340	1,4	42,00	HW040+NMRV-P110	90L	4	6865
31,3	338	0,8	30,00	NMRV-P075	100L	6	5122
31,3	347	1,4	30,00	NMRV-P090	100L	6	5667
31,3	352	2,4	30,00	NMRV-P110	100L	6	7161
31,3	361	3,2	30,00	NMRV130	100L	6	9366
30,6	373	2,1	46,58	HW040+NMRV-P110	90L	4	7157
30,2	368	1,5	46,58	HW040+NMRV-P090	90L	4	5637
29,0	366	1,0	50,00	NMRV-P090	90L	4	5799
29,0	381	1,7	50,00	NMRV-P110	90L	4	7328
29,0	351	1,0	100,00	NMRV-P110	90S	2	7328
24,2	421	0,8	60,00	NMRV-P090	90L	4	6163
24,0	445	1,4	60,00	NMRV-P110	90L	4	7787
23,2	439	1,0	40,00	NMRV-P090	100L	6	6238
23,2	457	1,7	40,00	NMRV-P110	100L	6	7882
23,2	463	2,3	40,00	NMRV130	100L	6	10309
23,2	489	1,3	63,00	HW040+NMRV-P090	90L	4	6234
23,0	485	1,9	62,11	HW040+NMRV-P110	90L	4	7822
19,2	549	1,3	50,00	NMRV-P110	100L	6	8491
19,2	556	1,9	50,00	NMRV130	100L	6	11105
19,0	564	2,8	50,00	NMRV150	100L	6	15182
18,4	569	0,9	77,63	HW040+NMRV-P090	90L	4	6715
18,4	591	1,6	77,63	HW040+NMRV-P110	90L	4	8485
18,4	545	0,9	80,00	NMRV-P110	90L	4	8571
18,4	553	1,5	80,00	NMRV130	90L	4	11210
17,1	643	1,4	84,00	HW040+NMRV-P110	90L	4	8670
17,0	627	0,9	84,00	HW040+NMRV-P090	90L	4	6845
16,2	631	1,1	60,00	NMRV-P110	100L	6	9023

## 1,50 kW

n2 [rpm]	M2 [Nm]	fs	i	Gear reducer	Motor		Fr2 [N]
					Size	Pole	
16,2	640	1,5	60,00	NMRV130	100L	6	11801
16,2	649	2,2	60,00	NMRV150	100L	6	16133
15,3	652	1,6	93,16	HW040+NMRV-P110	90L	4	9017
15,1	644	0,9	93,16	HW040+NMRV-P090	90L	4	7102
14,3	730	1,5	100,00	NMRV-P063/110	90L	4	8198
14,3	739	1,5	100,00	NMRV-P063/130	90L	4	10722
14,1	784	1,4	105,00	HW040+NMRV-P110	90L	4	9340
14,1	642	0,7	100,00	NMRV-P110	90L	4	9232
14,1	651	1,1	100,00	NMRV130	90L	4	12076
13,3	810	0,8	110,00	HW040+NMRV-P090	90L	4	7542
12,1	781	0,7	80,00	NMRV-P110	100L	6	9931
12,1	793	1,1	80,00	NMRV130	100L	6	12989
12,0	805	1,6	80,00	NMRV150	100L	6	17757
11,0	848	0,8	126,00	HW040+NMRV-P090	90L	4	7836
11,0	853	1,4	126,00	HW040+NMRV-P110	90L	4	9902
10,0	1012	0,9	137,50	HW040+NMRV-P110	90L	4	10194
9,5	1055	1,1	150,00	NMRV-P063/110	90L	4	9384
9,5	1042	1,5	150,00	NMRV-P063/130	90L	4	12274
9,5	1052	1,9	150,00	NMRV-P063/150	90L	4	18000
9,2	999	0,9	155,26	HW040+NMRV-P110	90L	4	10320
9,1	914	0,8	100,00	NMRV130	100L	6	13500
9,0	1105	1,0	168,00	HW040+NMRV-P110	90L	4	10320
9,0	930	1,2	100,00	NMRV150	100L	6	18000
8,0	1141	0,7	186,32	HW040+NMRV-P110	90L	4	10320
7,2	1371	0,8	200,00	NMRV-P063/110	90L	4	10320
7,2	1371	1,2	200,00	NMRV-P063/130	90L	4	13500
7,2	1371	1,5	200,00	NMRV-P063/150	90L	4	18000
6,0	1413	0,8	220,00	HW040+NMRV-P110	90L	4	10320
5,7	1669	0,7	250,00	NMRV-P063/110	90L	4	10320
5,7	1669	0,9	250,00	NMRV-P063/130	90L	4	13500
5,7	1669	1,2	250,00	NMRV-P063/150	90L	4	18000
4,8	1789	0,7	300,00	NMRV-P063/110	90L	4	10320
4,8	1816	1,0	300,00	NMRV-P063/130	90L	4	13500
4,8	1985	1,2	300,00	NMRV-P063/150	90L	4	18000
3,6	2315	0,7	400,00	NMRV-P063/130	90L	4	13500
3,6	2350	1,1	400,00	NMRV-P063/150	90L	4	18000
2,9	2760	0,8	500,00	NMRV-P063/150	90L	4	18000
2,4	3404	0,8	600,00	NMRV-P063/150	90L	4	18000

## 2,20 kW

n2 [rpm]	M2 [Nm]	fs	i	Gear reducer	Motor		Fr2 [N]
					Size	Pole	
384,0	50	1,9	7,50	NMRV-P063	90L	2	1873
384,0	50	2,6	7,50	NMRV-P075	90L	2	2210
288,0	65	1,5	10,00	NMRV-P063	90L	2	2061
288,0	66	2,3	10,00	NMRV-P075	90L	2	2433
288,0	66	3,6	10,00	NMRV-P090	90L	2	2692
192,3	95	1,1	15,00	NMRV-P063	90L	2	2359
192,3	96	1,7	15,00	NMRV-P075	90L	2	2785
192,3	97	2,8	15,00	NMRV-P090	90L	2	3081
191,7	98	1,9	7,50	NMRV-P075	100LA	4	2785
191,7	99	3,2	7,50	NMRV-P090	100LA	4	3081
144,0	124	0,8	20,00	NMRV-P063	90L	2	2597
144,0	129	1,6	10,00	NMRV-P075	100LA	4	3065
144,0	125	1,4	20,00	NMRV-P075	90L	2	3065
144,0	130	2,6	10,00	NMRV-P090	100LA	4	3391
144,0	128	2,0	20,00	NMRV-P090	90L	2	3391
144,0	130	3,7	20,00	NMRV-P110	90L	2	4285
128,0	144	1,4	7,50	NMRV-P075	112M	6	3227
128,0	146	2,6	7,50	NMRV-P090	112M	6	3570
115,0	153	1,0	25,00	NMRV-P075	90L	2	3302
115,0	157	1,6	25,00	NMRV-P090	90L	2	3653
114,8	161	3,1	25,00	NMRV-P110	90L	2	4616
96,0	188	1,2	10,00	NMRV-P075	112M	6	3551
96,0	191	2,2	10,00	NMRV-P090	112M	6	3929
96,0	182	1,7	30,00	NMRV-P090	90L	2	3882
96,0	193	3,7	10,00	NMRV-P110	112M	6	4965
96,0	184	3,0	30,00	NMRV-P110	90L	2	4905
95,7	189	1,2	15,00	NMRV-P075	100LA	4	3509
95,7	178	1,0	30,00	NMRV-P075	90L	2	3509
95,7	191	2,1	15,00	NMRV-P090	100LA	4	3882
95,7	191	3,4	15,00	NMRV-P110	100LA	4	4905
72,5	233	1,2	40,00	NMRV-P090	90L	2	4273
72,5	242	2,2	40,00	NMRV-P110	90L	2	5399
72,0	243	1,0	20,00	NMRV-P075	100LA	4	3862
72,0	228	0,8	40,00	NMRV-P075	90L	2	3862
72,0	249	1,6	20,00	NMRV-P090	100LA	4	4273
72,0	251	2,6	20,00	NMRV-P110	100LA	4	5399
64,0	272	0,9	15,00	NMRV-P075	112M	6	4065
64,0	279	1,7	15,00	NMRV-P090	112M	6	4498
64,0	282	2,7	15,00	NMRV-P110	112M	6	5684
58,0	292	1,7	50,00	NMRV-P110	90L	2	5816
57,4	296	0,7	25,00	NMRV-P075	100LA	4	4160
57,4	281	0,9	50,00	NMRV-P090	90L	2	4603



## 2,20 kW

n2 [rpm]	M2 [Nm]	fs	i	Gear reducer	Motor		Fr2 [N]
					Size	Pole	
57,2	303	1,3	25,00	NMRV-P090	100LA	4	4603
57,2	310	2,2	25,00	NMRV-P110	100LA	4	5816
57,2	310	3,0	25,00	NMRV130	100LA	4	7607
48,5	368	2,0	20,00	NMRV-P110	112M	6	6256
48,3	329	0,7	60,00	NMRV-P090	90L	2	4891
48,3	351	2,1	30,00	NMRV-P110	100LA	4	6181
48,3	342	1,4	60,00	NMRV-P110	90L	2	6181
48,0	350	0,8	20,00	NMRV-P075	112M	6	4474
48,0	359	1,2	20,00	NMRV-P090	112M	6	4951
48,0	355	2,9	30,00	NMRV130	100LA	4	8084
47,7	337	0,7	30,00	NMRV-P075	100LA	4	4421
47,7	346	1,2	30,00	NMRV-P090	100LA	4	4891
38,2	454	2,3	25,00	NMRV130	112M	6	8814
38,0	438	0,9	25,00	NMRV-P090	112M	6	5333
38,0	449	1,7	25,00	NMRV-P110	112M	6	6739
36,5	462	1,5	40,00	NMRV-P110	100LA	4	6803
36,5	462	2,2	40,00	NMRV130	100LA	4	8897
36,0	444	0,9	40,00	NMRV-P090	100LA	4	5383
36,0	432	0,9	80,00	NMRV-P110	90L	2	6803
32,0	499	1,0	30,00	NMRV-P090	112M	6	5667
32,0	506	1,7	30,00	NMRV-P110	112M	6	7161
32,0	519	2,3	30,00	NMRV130	112M	6	9366
29,0	533	0,7	50,00	NMRV-P090	100LA	4	5799
29,0	511	0,7	100,00	NMRV-P110	90L	2	7328
28,6	555	1,2	50,00	NMRV-P110	100LA	4	7328
28,6	555	1,8	50,00	NMRV130	100LA	4	9584
28,4	562	2,5	50,00	NMRV150	100LA	4	13103
24,2	640	1,4	60,00	NMRV130	100LA	4	10185
24,0	630	0,7	40,00	NMRV-P090	112M	6	6238
24,0	657	1,2	40,00	NMRV-P110	112M	6	7882
24,0	648	1,0	60,00	NMRV-P110	100LA	4	7787
24,0	648	1,9	60,00	NMRV150	100LA	4	13924
23,7	666	1,7	40,00	NMRV130	112M	6	10309
19,6	799	1,3	50,00	NMRV130	112M	6	11105
19,0	788	0,9	50,00	NMRV-P110	112M	6	8491
19,0	810	2,0	50,00	NMRV150	112M	6	15182
18,3	806	1,0	80,00	NMRV130	100LA	4	11210
18,3	806	1,4	80,00	NMRV150	100LA	4	15325
16,5	919	1,0	60,00	NMRV130	112M	6	11801
16,0	906	0,8	60,00	NMRV-P110	112M	6	9023
16,0	932	1,5	60,00	NMRV150	112M	6	16133
14,2	949	0,8	100,00	NMRV130	100LA	4	12076

## 2,20 kW

n2 [rpm]	M2 [Nm]	fs	i	Gear reducer	Size	Motor Pole	Fr2 [N]
14,2	949	1,0	100,00	NMRV150	100LA	4	16508
12,4	1138	0,7	80,00	NMRV130	112M	6	12989
12,0	1156	1,1	80,00	NMRV150	112M	6	17757
10,0	1335	0,9	100,00	NMRV150	112M	6	18000

## 3,00 kW

n2 [rpm]	M2 [Nm]	fs	i	Gear reducer	Size	Motor Pole	Fr2 [N]
387,0	67	1,9	7,50	NMRV-P075	100L	2	2210
387,0	68	3,0	7,50	NMRV-P090	100L	2	2446
290,0	89	1,7	10,00	NMRV-P075	100L	2	2433
290,0	89	2,6	10,00	NMRV-P090	100L	2	2692
193,0	132	1,4	7,50	NMRV-P075	112MS	4	2785
193,0	133	2,4	7,50	NMRV-P090	112MS	4	3081
193,0	132	2,0	15,00	NMRV-P090	100L	2	3081
193,0	131	1,3	15,00	NMRV-P075	100L	2	2785
193,0	134	3,6	15,00	NMRV-P110	100L	2	3893
145,5	170	1,0	20,00	NMRV-P075	100L	2	3065
145,5	174	1,5	20,00	NMRV-P090	100L	2	3391
145,5	176	2,7	20,00	NMRV-P110	100L	2	4285
145,0	174	1,2	10,00	NMRV-P075	112MS	4	3065
145,0	176	1,9	10,00	NMRV-P090	112MS	4	3391
145,0	176	3,4	10,00	NMRV-P110	112MS	4	4285
129,0	197	3,3	7,50	NMRV-P110	132S	6	4511
116,2	208	0,8	25,00	NMRV-P075	100L	2	3302
116,2	213	1,2	25,00	NMRV-P090	100L	2	3653
116,2	218	2,3	25,00	NMRV-P110	100L	2	4616
97,0	240	0,8	30,00	NMRV-P075	100L	2	3509
97,0	246	1,2	30,00	NMRV-P090	100L	2	3882
97,0	249	2,2	30,00	NMRV-P110	100L	2	4905
97,0	255	0,9	15,00	NMRV-P075	112MS	4	3509
97,0	258	1,5	15,00	NMRV-P090	112MS	4	3882
97,0	260	2,7	10,00	NMRV-P110	132S	6	4965
97,0	258	2,5	15,00	NMRV-P110	112MS	4	4905
97,0	260	3,7	10,00	NMRV130	132S	6	6494
73,0	328	0,7	20,00	NMRV-P075	112MS	4	3862
73,0	336	1,2	20,00	NMRV-P090	112MS	4	4273
73,0	316	0,9	40,00	NMRV-P090	100L	2	4273
73,0	340	1,9	20,00	NMRV-P110	112MS	4	5399
73,0	328	1,6	40,00	NMRV-P110	100L	2	5399
64,7	381	2,0	15,00	NMRV-P110	132S	6	5684
64,7	377	2,8	15,00	NMRV130	132S	6	7434

## 3,00 kW

n2 [rpm]	M2 [Nm]	fs	i	Gear reducer	Motor		Fr2 [N]
					Size	Pole	
58,0	410	0,9	25,00	NMRV-P090	112MS	4	4603
58,0	420	1,6	25,00	NMRV-P110	112MS	4	5816
58,0	395	1,3	50,00	NMRV-P110	100L	2	5816
58,0	420	2,2	25,00	NMRV130	112MS	4	7607
49,0	496	1,5	20,00	NMRV-P110	132S	6	6256
49,0	502	2,1	20,00	NMRV130	132S	6	8182
49,0	502	3,0	20,00	NMRV150	132S	6	11186
48,5	462	1,0	60,00	NMRV-P110	100L	2	6181
48,0	468	0,9	30,00	NMRV-P090	112MS	4	4891
48,0	474	1,5	30,00	NMRV-P110	112MS	4	6181
48,0	480	2,2	30,00	NMRV130	112MS	4	8084
39,0	613	1,7	25,00	NMRV130	132S	6	8814
38,4	606	1,2	25,00	NMRV-P110	132S	6	6739
38,4	621	2,2	25,00	NMRV150	132S	6	12050
36,0	624	1,1	40,00	NMRV-P110	112MS	4	6803
36,0	624	1,7	40,00	NMRV130	112MS	4	8897
32,0	682	1,2	30,00	NMRV-P110	132S	6	7161
32,0	700	1,7	30,00	NMRV130	132S	6	9366
32,0	727	1,9	30,00	NMRV150	132S	6	12805
29,0	751	0,9	50,00	NMRV-P110	112MS	4	7328
29,0	751	1,3	50,00	NMRV130	112MS	4	9584
29,0	761	1,8	50,00	NMRV150	112MS	4	13103
24,0	886	0,9	40,00	NMRV-P110	132S	6	7882
24,0	877	0,7	60,00	NMRV-P110	112MS	4	7787
24,0	898	1,2	40,00	NMRV130	132S	6	10309
24,0	865	1,0	60,00	NMRV130	112MS	4	10185
24,0	898	2,0	40,00	NMRV150	132S	6	14094
24,0	877	1,4	60,00	NMRV150	112MS	4	13924
19,0	1063	0,7	50,00	NMRV-P110	132S	6	8491
19,0	1093	1,5	50,00	NMRV150	132S	6	15182
18,0	1091	0,8	80,00	NMRV130	112MS	4	11210
18,0	1091	1,1	80,00	NMRV150	112MS	4	15325
16,0	1258	1,1	60,00	NMRV150	132S	6	16133

## 4,00 kW

n2 [rpm]	M2 [Nm]	fs	i	Gear reducer	Motor		Fr2 [N]
					Size	Pole	
391,0	89	1,5	7,50	NMRV-P075	112M	2	2210
391,0	90	2,3	7,50	NMRV-P090	112M	2	2446
293,0	118	1,3	10,00	NMRV-P075	112M	2	2433
293,0	118	2,0	10,00	NMRV-P090	112M	2	2692
293,0	119	3,7	10,00	NMRV-P110	112M	2	3401

## 4,00 kW

n <sub>2</sub> [rpm]	M <sub>2</sub> [Nm]	f <sub>s</sub>	i	Gear reducer	Motor		Fr <sub>2</sub> [N]
					Size	Pole	
195,0	172	0,9	15,00	NMRV-P075	112M	2	2785
195,0	174	1,5	15,00	NMRV-P090	112M	2	3081
195,0	176	2,7	15,00	NMRV-P110	112M	2	3893
193,0	176	1,1	7,50	NMRV-P075	112M	4	2785
193,0	178	1,8	7,50	NMRV-P090	112M	4	3081
193,0	178	3,1	7,50	NMRV-P110	112M	4	3893
147,0	232	2,1	20,00	NMRV-P110	112M	2	4285
146,5	225	0,8	20,00	NMRV-P075	112M	2	3065
146,5	230	1,1	20,00	NMRV-P090	112M	2	3391
145,0	232	0,9	10,00	NMRV-P075	112M	4	3065
145,0	234	1,4	10,00	NMRV-P090	112M	4	3391
145,0	234	2,5	10,00	NMRV-P110	112M	4	4285
129,3	263	2,4	7,50	NMRV-P110	132MA	6	4511
129,3	266	3,3	7,50	NMRV130	132MA	6	5901
117,2	280	0,9	25,00	NMRV-P090	112M	2	3653
117,2	287	1,7	25,00	NMRV-P110	112M	2	4616
98,0	325	1,0	30,00	NMRV-P090	112M	2	3882
98,0	329	1,7	30,00	NMRV-P110	112M	2	4905
97,0	344	1,2	15,00	NMRV-P090	112M	4	3882
97,0	347	2,1	10,00	NMRV-P110	132MA	6	4965
97,0	344	1,9	15,00	NMRV-P110	112M	4	4905
97,0	347	2,8	10,00	NMRV130	132MA	6	6494
73,0	448	0,9	20,00	NMRV-P090	112M	4	4273
73,0	453	1,4	20,00	NMRV-P110	112M	4	5399
73,0	433	1,2	40,00	NMRV-P110	112M	2	5399
65,0	508	1,5	15,00	NMRV-P110	132MA	6	5684
65,0	502	2,1	15,00	NMRV130	132MA	6	7434
59,0	522	0,9	50,00	NMRV-P110	112M	2	5816
58,4	560	1,2	25,00	NMRV-P110	112M	4	5816
58,4	560	1,6	25,00	NMRV130	112M	4	7607
49,0	610	0,8	60,00	NMRV-P110	112M	2	6181
48,5	662	1,1	20,00	NMRV-P110	132MA	6	6256
48,5	669	1,5	20,00	NMRV130	132MA	6	8182
48,5	669	2,2	20,00	NMRV150	132MA	6	11186
48,3	633	1,1	30,00	NMRV-P110	112M	4	6181
48,3	641	1,6	30,00	NMRV130	112M	4	8084
38,4	808	0,9	25,00	NMRV-P110	132MA	6	6739
38,4	818	1,3	25,00	NMRV130	132MA	6	8814
38,4	827	1,7	25,00	NMRV150	132MA	6	12050
36,2	832	0,8	40,00	NMRV-P110	112M	4	6803
36,2	832	1,3	40,00	NMRV130	112M	4	8897
32,3	933	1,2	30,00	NMRV130	132MA	6	9366

## 4,00 kW

n <sub>2</sub> [rpm]	M <sub>2</sub> [Nm]	f <sub>s</sub>	i	Gear reducer	Motor		Fr <sub>2</sub> [N]
					Size	Pole	
32,0	910	0,9	30,00	NMRV-P110	132MA	6	7161
32,0	969	1,4	30,00	NMRV150	132MA	6	12805
29,2	1001	1,0	50,00	NMRV130	112M	4	9584
29,0	1014	1,4	50,00	NMRV150	112M	4	13103
24,2	1198	0,9	40,00	NMRV130	132MA	6	10309
24,2	1198	1,5	40,00	NMRV150	132MA	6	14094
24,0	1154	0,8	60,00	NMRV130	112M	4	10185
24,0	1170	1,1	60,00	NMRV150	112M	4	13924
19,0	1457	1,1	50,00	NMRV150	132MA	6	15182
16,0	1678	0,9	60,00	NMRV150	132MA	6	16133

## 5,50 kW

n <sub>2</sub> [rpm]	M <sub>2</sub> [Nm]	f <sub>s</sub>	i	Gear reducer	Motor		Fr <sub>2</sub> [N]
					Size	Pole	
393,3	123	3,1	7,50	NMRV-P110	132S	2	3090
295,0	162	2,7	10,00	NMRV-P110	132S	2	3401
196,7	241	2,0	15,00	NMRV-P110	132S	2	3893
196,3	244	3,1	7,50	NMRV130	132MS	4	5092
195,7	242	2,3	7,50	NMRV-P110	132MS	4	3893
148,0	317	1,5	20,00	NMRV-P110	132S	2	4285
147,0	318	1,9	10,00	NMRV-P110	132MS	4	4285
147,0	318	2,6	10,00	NMRV130	132MS	4	5605
129,3	361	1,8	7,50	NMRV-P110	132MB	6	4511
129,0	366	2,4	7,50	NMRV130	132MB	6	5901
118,0	392	1,3	25,00	NMRV-P110	132S	2	4616
98,3	467	1,4	15,00	NMRV-P110	132MS	4	4905
98,3	467	1,9	15,00	NMRV130	132MS	4	6416
98,0	449	1,2	30,00	NMRV-P110	132S	2	4905
97,0	477	1,5	10,00	NMRV-P110	132MB	6	4965
97,0	477	2,0	10,00	NMRV130	132MB	6	6494
74,0	615	1,0	20,00	NMRV-P110	132MS	4	5399
74,0	591	0,9	40,00	NMRV-P110	132S	2	5399
74,0	622	1,5	20,00	NMRV130	132MS	4	7062
74,0	622	2,1	20,00	NMRV150	132MS	4	9654
65,0	699	1,1	15,00	NMRV-P110	132MB	6	5684
64,7	691	1,5	15,00	NMRV130	132MB	6	7434
58,8	760	0,9	25,00	NMRV-P110	132MS	4	5816
58,8	760	1,2	25,00	NMRV130	132MS	4	7607
58,8	760	1,6	25,00	NMRV150	132MS	4	10400
49,3	868	1,2	30,00	NMRV130	132MS	4	8084
49,3	901	1,3	30,00	NMRV150	132MS	4	11051
49,0	910	0,8	20,00	NMRV-P110	132MB	6	6256

## 5,50 kW

n <sub>2</sub> [rpm]	M <sub>2</sub> [Nm]	f <sub>s</sub>	i	Gear reducer	Motor		Fr <sub>2</sub> [N]
					Size	Pole	
49,0	858	0,8	30,00	NMRV-P110	132MS	4	6181
49,0	921	1,1	20,00	NMRV130	132MB	6	8182
49,0	921	1,6	20,00	NMRV150	132MB	6	11186
39,0	1124	0,9	25,00	NMRV130	132MB	6	8814
38,4	1137	1,2	25,00	NMRV150	132MB	6	12050
36,5	1129	0,9	40,00	NMRV130	132MS	4	8897
36,5	1129	1,4	40,00	NMRV150	132MS	4	12163
32,3	1284	0,9	30,00	NMRV130	132MB	6	9366
32,3	1332	1,0	30,00	NMRV150	132MB	6	12805
29,4	1376	1,0	50,00	NMRV150	132MS	4	13103
24,0	1646	1,1	40,00	NMRV150	132MB	6	14094
19,0	2004	0,8	50,00	NMRV150	132MB	6	15182

## 7,50 kW

n <sub>2</sub> [rpm]	M <sub>2</sub> [Nm]	f <sub>s</sub>	i	Gear reducer	Motor		Fr <sub>2</sub> [N]
					Size	Pole	
393,0	168	2,3	7,50	NMRV-P110	132M	2	3090
295,0	221	2,0	10,00	NMRV-P110	132M	2	3401
197,0	328	1,5	15,00	NMRV-P110	132M	2	3893
195,0	331	1,7	7,50	NMRV-P110	132M	4	3893
195,0	335	2,2	7,50	NMRV130	132M	4	5092
148,0	432	1,1	20,00	NMRV-P110	132M	2	4285
146,0	437	1,4	10,00	NMRV-P110	132M	4	4285
146,0	437	1,9	10,00	NMRV130	132M	4	5605
97,7	641	1,0	15,00	NMRV-P110	132M	4	4905
97,7	641	1,4	15,00	NMRV130	132M	4	6416
73,5	844	0,8	20,00	NMRV-P110	132M	4	5399
73,5	854	1,1	20,00	NMRV130	132M	4	7062
73,5	854	1,5	20,00	NMRV150	132M	4	9654
58,4	1043	0,9	25,00	NMRV130	132M	4	7607
58,4	1043	1,1	25,00	NMRV150	132M	4	10400
49,0	1192	0,9	30,00	NMRV130	132M	4	8084
48,3	1237	1,0	30,00	NMRV150	132M	4	11051
36,2	1550	1,0	40,00	NMRV150	132M	4	12163

## 11,00 kW

n <sub>2</sub> [rpm]	M <sub>2</sub> [Nm]	f <sub>s</sub>	i	Gear reducer	Motor		Fr <sub>2</sub> [N]
					Size	Pole	
197,0	486	2,5	7,50	NMRV150	160MA	4	6962
148,0	641	1,9	10,00	NMRV150	160MA	4	7663
129,0	731	1,9	7,50	NMRV150	160L	6	8067

## 11,00 kW

n <sub>2</sub> [rpm]	M <sub>2</sub> [Nm]	f <sub>s</sub>	i	Gear reducer	Motor		Fr <sub>2</sub> [N]
					Size	Pole	
98,0	940	1,3	15,00	NMRV150	160MA	4	8771
97,0	964	1,5	10,00	NMRV150	160L	6	8878
74,0	1239	1,0	20,00	NMRV150	160MA	4	9654
65,0	1413	1,0	15,00	NMRV150	160L	6	10163
49,0	1841	0,8	20,00	NMRV150	160L	6	11186

## 15,00 kW

n <sub>2</sub> [rpm]	M <sub>2</sub> [Nm]	f <sub>s</sub>	i	Gear reducer	Motor		Fr <sub>2</sub> [N]
					Size	Pole	
197,0	663	1,8	7,50	NMRV150	160LA	4	6962
148,0	874	1,4	10,00	NMRV150	160LA	4	7663
98,0	1282	1,0	15,00	NMRV150	160LA	4	8771

## NRV030

$Mn_2$ [Nm]	i	$Pn_1$ [kW]	n2 [rpm]	Fr1 [N]	Fr2 [N]
12	5,00	0,79	560,0	115	474
13	7,50	0,58	373,0	125	542
13	10,00	0,44	280,0	140	597
13	15,00	0,31	187,0	140	683
12	20,00	0,22	140,0	146	752
16	25,00	0,25	112,0	210	810
15	30,00	0,20	93,0	210	861
14	40,00	0,15	70,0	127	948
13	50,00	0,12	56,0	128	1021
12	60,00	0,10	47,0	126	1085
11	80,00	0,08	35,0	130	1194

## NRV040

$Mn_2$ [Nm]	i	$Pn_1$ [kW]	n2 [rpm]	Fr1 [N]	Fr2 [N]
24	5,00	1,56	560,0	200	912
28	7,50	1,23	373,0	233	1044
29	10,00	0,97	280,0	272	1149
31	15,00	0,71	187,0	291	1315
29	20,00	0,51	140,0	204	1447
28	25,00	0,41	112,0	236	1559
34	30,00	0,43	93,0	350	1657
31	40,00	0,31	70,0	350	1824
30	50,00	0,25	56,0	350	1964
28	60,00	0,21	47,0	350	2087
25	80,00	0,15	35,0	350	2298
23	100,00	0,12	28,0	350	2475

## NRV050

$Mn_2$ [Nm]	i	$Pn_1$ [kW]	n2 [rpm]	Fr1 [N]	Fr2 [N]
45	5,00	2,90	560,0	280	1251
52	7,50	2,26	373,0	324	1433
54	10,00	1,78	280,0	378	1577
57	15,00	1,30	187,0	399	1805
53	20,00	0,94	140,0	417	1987
51	25,00	0,74	112,0	482	2140
64	30,00	0,81	93,0	490	2274
59	40,00	0,58	70,0	490	2503
53	50,00	0,44	56,0	490	2696
50	60,00	0,36	47,0	490	2865



## NRV050

$Mn_2$ [Nm]	i	$Pn_1$ [kW]	n2 [rpm]	Fr1 [N]	Fr2 [N]
45	80,00	0,27	35,0	490	3153
40	100,00	0,21	28,0	490	3397

## NRV-P063

$Mn_2$ [Nm]	i	$Pn_1$ [kW]	n2 [rpm]	Fr1 [N]	Fr2 [N]
94	7,50	4,03	373,0	395	1873
99	10,00	3,27	280,0	471	2061
109	15,00	2,45	187,0	516	2359
104	20,00	1,80	140,0	556	2597
96	25,00	1,35	112,0	613	2797
121	30,00	1,49	93,0	700	2973
113	40,00	1,09	70,0	700	3272
105	50,00	0,85	56,0	700	3524
99	60,00	0,70	47,0	700	3745
88	80,00	0,50	35,0	700	4122
79	100,00	0,39	28,0	700	4440

## NRV-P075

$Mn_2$ [Nm]	i	$Pn_1$ [kW]	n2 [rpm]	Fr1 [N]	Fr2 [N]
131	7,50	5,61	373,0	560	2210
151	10,00	4,93	280,0	729	2433
165	15,00	3,66	187,0	795	2785
173	20,00	2,94	140,0	935	3065
159	25,00	2,21	112,0	980	3302
185	30,00	2,24	93,0	980	3509
182	40,00	1,71	70,0	980	3862
165	50,00	1,29	56,0	980	4160
159	60,00	1,08	47,0	980	4421
141	80,00	0,77	35,0	980	4865
131	100,00	0,62	28,0	980	5241

## NRV-P090

$Mn_2$ [Nm]	i	$Pn_1$ [kW]	n2 [rpm]	Fr1 [N]	Fr2 [N]
210	7,50	8,92	373,0	715	2446
235	10,00	7,66	280,0	900	2692
270	15,00	5,93	187,0	1034	3081
260	20,00	4,33	140,0	1120	3391

## NRV-P090

$Mn_2$ [Nm]	i	$Pn_1$ [kW]	n2 [rpm]	Fr1 [N]	Fr2 [N]
250	25,00	3,41	112,0	1270	3653
310	30,00	3,65	93,0	1270	3882
275	40,00	2,52	70,0	1270	4273
265	50,00	2,02	56,0	1270	4603
245	60,00	1,60	47,0	1270	4891
225	80,00	1,18	35,0	1270	5383
200	100,00	0,89	28,0	1270	5799

## NRV-P110

$Mn_2$ [Nm]	i	$Pn_1$ [kW]	n2 [rpm]	Fr1 [N]	Fr2 [N]
391	7,50	16,61	373,0	950	3090
437	10,00	14,08	280,0	1194	3401
489	15,00	10,62	187,0	1337	3893
483	20,00	7,96	140,0	1485	4285
506	25,00	6,74	112,0	1700	4616
552	30,00	6,42	93,0	1700	4905
529	40,00	4,67	70,0	1700	5399
495	50,00	3,63	56,0	1700	5816
473	60,00	2,96	47,0	1700	6181
399	80,00	1,98	35,0	1700	6803
368	100,00	1,54	28,0	1700	7328

## NRV130

$Mn_2$ [Nm]	i	$Pn_1$ [kW]	n2 [rpm]	Fr1 [N]	Fr2 [N]
520	7,50	22,10	373,0	1190	4042
580	10,00	18,69	280,0	1493	4449
670	15,00	14,71	187,0	1725	5092
660	20,00	10,87	140,0	1912	5605
670	25,00	8,93	112,0	2100	6038
770	30,00	8,85	93,0	2100	6416
730	40,00	6,45	70,0	2100	7062
700	50,00	5,07	56,0	2100	7607
640	60,00	3,96	47,0	2100	8084
590	80,00	2,92	35,0	2100	8897
520	100,00	2,15	28,0	2100	9584

## NRV150

$Mn_2$ [Nm]	$i$	$Pn_1$ [kW]	$n_2$ [rpm]	$Fr_1$ [N]	$Fr_2$ [N]
840	7,50	35,69	373,0	1550	5526
890	10,00	28,36	280,0	1848	6082
910	15,00	19,76	187,0	1889	6962
980	20,00	15,96	140,0	2289	7663
890	25,00	11,86	112,0	2494	8254
920	30,00	10,33	93,0	2800	8771
1200	40,00	10,47	70,0	2800	9654
1100	50,00	7,96	56,0	2800	10400
990	60,00	6,12	47,0	2800	11051
920	80,00	4,50	35,0	2800	12163
810	100,00	3,30	28,0	2800	13103

## NRV030/040

Mn <sub>2</sub> [Nm]	i	Pn <sub>1</sub> [kW]	n <sub>2</sub> [rpm]	Fr1 [N]	Fr2 [N]
71	100,00	0,31	28,0	140	2769
72	150,00	0,22	18,7	140	3169
65	200,00	0,16	14,0	140	3488
61	250,00	0,13	11,2	140	3490
73	300,00	0,14	9,3	140	3490
65	400,00	0,10	7,0	140	3490
61	500,00	0,07	5,6	146	3490
73	600,00	0,08	4,7	146	3490
73	750,00	0,06	3,7	210	3490
73	900,00	0,06	3,1	210	3490
73	1200,00	0,04	2,3	127	3490
73	1500,00	0,04	1,9	128	3490
73	1800,00	0,03	1,6	126	3490
65	2400,00	0,03	1,2	126	3490
60	3000,00	0,02	0,9	126	3490
48	4000,00	0,01	0,7	128	3490
43	5000,00	0,01	0,6	128	3490

## NRV030/050

Mn <sub>2</sub> [Nm]	i	Pn <sub>1</sub> [kW]	n <sub>2</sub> [rpm]	Fr1 [N]	Fr2 [N]
103	100,00	0,44	28,0	140	3800
135	150,00	0,42	18,7	140	4350
120	200,00	0,30	14,0	140	4788
110	250,00	0,23	11,2	140	4840
145	300,00	0,27	9,3	140	4840
124	400,00	0,20	7,0	140	4840
120	500,00	0,16	5,6	140	4840
145	600,00	0,15	4,7	146	4840
145	750,00	0,13	3,7	210	4840
145	900,00	0,11	3,1	210	4840
145	1200,00	0,09	2,3	127	4840
145	1500,00	0,07	1,9	128	4840
145	1800,00	0,07	1,6	126	4840
124	2400,00	0,05	1,2	126	4840
120	3000,00	0,04	0,9	126	4840
82	4000,00	0,02	0,7	128	4840
79	5000,00	0,02	0,6	128	4840

## NRV-P030/063

$Mn_2$ [Nm]	i	$Pn_1$ [kW]	n2 [rpm]	Fr1 [N]	Fr2 [N]
103	100,00	0,44	28,0	140	4967
144	150,00	0,44	18,7	140	5686
182	200,00	0,44	14,0	140	6259
218	250,00	0,44	11,2	140	6270
255	300,00	0,51	9,3	125	6270
255	400,00	0,39	7,0	140	6270
236	500,00	0,31	5,6	140	6270
220	600,00	0,22	4,7	146	6270
271	750,00	0,23	3,7	210	6270
271	900,00	0,20	3,1	210	6270
256	1200,00	0,15	2,3	127	6270
238	1500,00	0,12	1,9	128	6270
220	1800,00	0,10	1,6	126	6270
255	2400,00	0,09	1,2	126	6270
236	3000,00	0,08	0,9	126	6270
236	4000,00	0,06	0,7	130	6270
150	5000,00	0,04	0,6	128	6270

## NRV040/050

$Mn_2$ [Nm]	i	$Pn_1$ [kW]	n2 [rpm]	Fr1 [N]	Fr2 [N]
137	100,00	0,58	28,0	272	3800
135	150,00	0,41	18,7	272	4350
120	200,00	0,29	14,0	272	4788
110	250,00	0,23	11,2	272	4840
145	300,00	0,27	9,3	272	4840
124	400,00	0,19	7,0	272	4840
137	500,00	0,15	5,6	350	3800
145	600,00	0,14	4,7	204	4840
145	750,00	0,12	3,7	236	4840
135	900,00	0,09	3,1	350	4350
145	1200,00	0,08	2,3	350	4840
145	1500,00	0,07	1,9	350	4840
145	1800,00	0,06	1,6	350	4840
124	2400,00	0,04	1,2	350	4840
120	3000,00	0,04	0,9	350	4840
120	4000,00	0,03	0,7	350	4840
120	5000,00	0,03	0,6	350	4840

## NRV-P040/063

$Mn_2$ [Nm]	i	$Pn_1$ [kW]	n2 [rpm]	Fr1 [N]	Fr2 [N]
229	100,00	0,97	28,0	272	4967
260	150,00	0,78	18,7	272	5686
253	200,00	0,60	14,0	272	6259
231	250,00	0,46	11,2	272	6270
271	300,00	0,49	9,3	272	6270
255	400,00	0,38	7,0	272	6270
231	500,00	0,24	5,6	204	6270
271	600,00	0,26	4,7	204	6270
271	750,00	0,22	3,7	236	6270
271	900,00	0,19	3,1	350	6270
271	1200,00	0,15	2,3	350	6270
271	1500,00	0,13	1,9	350	6270
271	1800,00	0,11	1,6	350	6270
255	2400,00	0,08	1,2	350	6270
236	3000,00	0,07	0,9	350	6270
236	4000,00	0,06	0,7	350	6270
236	5000,00	0,05	0,6	350	6270

## NRV-P040/075

$Mn_2$ [Nm]	i	$Pn_1$ [kW]	n2 [rpm]	Fr1 [N]	Fr2 [N]
232	100,00	0,97	28,0	272	5863
331	150,00	0,97	18,7	272	6712
418	200,00	0,97	14,0	272	7380
380	250,00	0,73	11,2	272	7380
444	300,00	0,77	9,3	272	7380
414	400,00	0,58	7,0	272	7380
368	500,00	0,45	5,6	272	7380
444	600,00	0,41	4,7	204	7380
444	750,00	0,34	3,7	236	7380
444	900,00	0,29	3,1	350	7380
444	1200,00	0,23	2,3	350	7380
444	1500,00	0,20	1,9	350	7380
444	1800,00	0,17	1,6	350	7380
414	2400,00	0,13	1,2	350	7380
368	3000,00	0,10	0,9	350	7380
368	4000,00	0,08	0,7	350	7380
368	5000,00	0,07	0,6	350	7380

## NRV-P040/090

$Mn_2$ [Nm]	i	$Pn_1$ [kW]	n2 [rpm]	Fr1 [N]	Fr2 [N]
238	100,00	0,97	28,0	272	6487
339	150,00	0,97	18,7	272	7426
435	200,00	0,97	14,0	272	8174
522	250,00	0,97	11,2	272	8180
583	300,00	0,97	9,3	272	8180
610	400,00	0,82	7,0	272	8180
560	500,00	0,64	5,6	272	8180
583	600,00	0,51	4,7	204	8180
563	750,00	0,41	3,7	236	8180
683	900,00	0,43	3,1	350	8180
623	1200,00	0,31	2,3	350	8180
603	1500,00	0,25	1,9	350	8180
563	1800,00	0,21	1,6	350	8180
610	2400,00	0,18	1,2	350	8180
560	3000,00	0,14	0,9	350	8180
560	4000,00	0,12	0,7	350	8180
560	5000,00	0,10	0,6	350	8180

## NRV-P050/090

$Mn_2$ [Nm]	i	$Pn_1$ [kW]	n2 [rpm]	Fr1 [N]	Fr2 [N]
443	100,00	1,78	28,0	378	6487
632	150,00	1,78	18,7	378	7426
610	200,00	1,34	14,0	378	8174
570	250,00	1,04	11,2	378	8180
700	300,00	1,15	9,3	378	8180
610	400,00	0,81	7,0	378	8180
570	500,00	0,56	5,6	417	8180
700	600,00	0,62	4,7	417	8180
700	750,00	0,50	3,7	482	8180
700	900,00	0,44	3,1	490	8180
700	1200,00	0,34	2,3	490	8180
700	1500,00	0,29	1,9	490	8180
700	1800,00	0,25	1,6	490	8180
610	2400,00	0,18	1,2	490	8180
560	3000,00	0,14	0,9	490	8180
560	4000,00	0,11	0,7	490	8180
560	5000,00	0,10	0,6	490	8180

## NRV-P050/110

$Mn_2$ [Nm]	i	$Pn_1$ [kW]	n2 [rpm]	Fr1 [N]	Fr2 [N]
443	100,00	1,78	28,0	378	8198
640	150,00	1,78	18,7	378	9384
832	200,00	1,78	14,0	378	10320
1013	250,00	1,78	11,2	378	10320
1085	300,00	1,78	9,3	378	10320
1185	400,00	1,50	7,0	378	10320
994	500,00	0,94	5,6	417	10320
1065	600,00	0,94	4,7	417	10320
1025	750,00	0,74	3,7	482	10320
1265	900,00	0,80	3,1	490	10320
1186	1200,00	0,58	2,3	490	10320
1065	1500,00	0,44	1,9	490	10320
1005	1800,00	0,36	1,6	490	10320
1185	2400,00	0,33	1,2	490	10320
1100	3000,00	0,26	0,9	490	10320
1100	4000,00	0,21	0,7	490	10320
1100	5000,00	0,18	0,6	490	10320

## NRV-P063/110

$Mn_2$ [Nm]	i	$Pn_1$ [kW]	n2 [rpm]	Fr1 [N]	Fr2 [N]
815	100,00	3,27	28,0	471	8198
1178	150,00	3,27	18,7	471	9384
1139	200,00	2,44	14,0	471	10320
1173	250,00	2,06	11,2	471	10320
1265	300,00	2,07	9,3	471	10320
1185	400,00	1,50	7,0	471	10320
1173	500,00	1,08	5,6	556	10320
1265	600,00	1,09	4,7	556	10320
1265	750,00	0,89	3,7	613	10320
1265	900,00	0,78	3,1	700	10320
1265	1200,00	0,61	2,3	700	10320
1265	1500,00	0,51	1,9	700	10320
1265	1800,00	0,45	1,6	700	10320
1185	2400,00	0,32	1,2	700	10320
1100	3000,00	0,25	0,9	700	10320
1100	4000,00	0,20	0,7	700	10320
1100	5000,00	0,18	0,6	700	10320



## NRV-P063/130

Mn <sub>2</sub> [Nm]	i	Pn <sub>1</sub> [kW]	n <sub>2</sub> [rpm]	Fr1 [N]	Fr2 [N]
825	100,00	3,27	28,0	471	10722
1163	150,00	3,27	18,7	471	12274
1531	200,00	3,27	14,0	471	13500
1530	250,00	2,69	11,2	471	13500
1760	300,00	2,84	9,3	471	13500
1650	400,00	2,09	7,0	471	13500
1550	500,00	1,65	5,6	471	13500
1760	600,00	1,49	4,7	556	13500
1760	750,00	1,22	3,7	613	13500
1760	900,00	1,07	3,1	700	13500
1760	1200,00	0,83	2,3	700	13500
1760	1500,00	0,70	1,9	700	13500
1760	1800,00	0,61	1,6	700	13500
1650	2400,00	0,45	1,2	700	13500
1550	3000,00	0,35	0,9	700	13500
1550	4000,00	0,28	0,7	700	13500
1550	5000,00	0,25	0,6	700	13500

## NRV-P063/150

Mn <sub>2</sub> [Nm]	i	Pn <sub>1</sub> [kW]	n <sub>2</sub> [rpm]	Fr1 [N]	Fr2 [N]
1444	150,00	4,03	18,7	395	18000
1531	200,00	3,27	14,0	471	18000
1864	250,00	3,27	11,2	471	18000
1678	300,00	2,45	9,3	516	18000
2624	400,00	3,27	7,0	471	18000
2330	500,00	2,48	5,6	471	18000
2670	600,00	2,27	4,7	516	18000
2330	750,00	1,69	3,7	516	18000
2100	900,00	1,19	3,1	700	18000
2670	1200,00	1,25	2,3	700	18000
2330	1500,00	0,93	1,9	700	18000
2100	1800,00	0,68	1,6	700	18000
2610	2400,00	0,70	1,2	700	18000
2330	3000,00	0,53	0,9	700	18000
2330	4000,00	0,43	0,7	700	18000
2330	5000,00	0,37	0,6	700	18000

## NRV030

Mn <sub>2</sub> [Nm]	i	Pn <sub>1</sub> [kW]	n <sub>2</sub> [rpm]	Fr1 [N]	Fr2 [N]
18	5,00	0,76	350,0	150	554
18	7,50	0,52	233,0	150	634
18	10,00	0,40	175,0	169	698
18	15,00	0,28	117,0	169	799
17	20,00	0,21	88,0	179	880
21	25,00	0,22	70,0	210	948
20	30,00	0,19	58,0	210	1007
18	40,00	0,14	44,0	210	1108
17	50,00	0,11	35,0	210	1194
15	60,00	0,09	29,0	210	1269
12	80,00	0,06	22,0	210	1396

## NRV040

Mn <sub>2</sub> [Nm]	i	Pn <sub>1</sub> [kW]	n <sub>2</sub> [rpm]	Fr1 [N]	Fr2 [N]
34	5,00	1,41	350,0	250	1066
40	7,50	1,12	233,0	291	1221
42	10,00	0,90	175,0	343	1344
42	15,00	0,62	117,0	343	1538
41	20,00	0,47	88,0	350	1693
37	25,00	0,36	70,0	350	1824
46	30,00	0,39	58,0	350	1938
43	40,00	0,30	44,0	350	2133
40	50,00	0,23	35,0	350	2298
36	60,00	0,19	29,0	350	2442
31	80,00	0,14	22,0	350	2687
28	100,00	0,11	18,0	350	2895

## NRV050

Mn <sub>2</sub> [Nm]	i	Pn <sub>1</sub> [kW]	n <sub>2</sub> [rpm]	Fr1 [N]	Fr2 [N]
65	5,00	2,66	350,0	350	1464
73	7,50	2,03	233,0	396	1676
75	10,00	1,58	175,0	490	1844
77	15,00	1,13	117,0	490	2111
74	20,00	0,85	88,0	490	2324
67	25,00	0,64	70,0	490	2503
84	30,00	0,70	58,0	490	2660
78	40,00	0,52	44,0	490	2927
73	50,00	0,42	35,0	490	3153
68	60,00	0,35	29,0	490	3351

## NRV050

$Mn_2$ [Nm]	i	$Pn_1$ [kW]	n2 [rpm]	Fr1 [N]	Fr2 [N]
62	80,00	0,26	22,0	490	3688
52	100,00	0,19	18,0	490	3973

## NRV-P063

$Mn_2$ [Nm]	i	$Pn_1$ [kW]	n2 [rpm]	Fr1 [N]	Fr2 [N]
122	7,50	3,32	233,0	500	2190
125	10,00	2,63	175,0	579	2411
140	15,00	2,02	117,0	646	2759
138	20,00	1,53	88,0	700	3037
127	25,00	1,17	70,0	700	3272
152	30,00	1,22	58,0	700	3477
142	40,00	0,91	44,0	700	3827
136	50,00	0,73	35,0	700	4122
128	60,00	0,61	29,0	700	4380
116	80,00	0,45	22,0	700	4821
112	100,00	0,38	18,0	700	5193

## NRV-P075

$Mn_2$ [Nm]	i	$Pn_1$ [kW]	n2 [rpm]	Fr1 [N]	Fr2 [N]
176	7,50	4,80	233,0	700	2585
187	10,00	3,88	175,0	839	2845
215	15,00	3,03	117,0	962	3257
221	20,00	2,42	88,0	980	3585
202	25,00	1,81	70,0	980	3862
229	30,00	1,80	58,0	980	4104
229	40,00	1,42	44,0	980	4517
212	50,00	1,10	35,0	980	4865
201	60,00	0,91	29,0	980	5170
184	80,00	0,68	22,0	980	5691
171	100,00	0,55	18,0	980	6130

## NRV-P090

$Mn_2$ [Nm]	i	$Pn_1$ [kW]	n2 [rpm]	Fr1 [N]	Fr2 [N]
303	7,50	8,19	233,0	900	2860
324	10,00	6,65	175,0	1082	3148
376	15,00	5,26	117,0	1257	3604
371	20,00	3,97	88,0	1270	3967

## NRV-P090

$Mn_2$ [Nm]	i	$Pn_1$ [kW]	n2 [rpm]	Fr1 [N]	Fr2 [N]
355	25,00	3,11	70,0	1270	4273
410	30,00	3,14	58,0	1270	4541
376	40,00	2,24	44,0	1270	4998
355	50,00	1,76	35,0	1270	5383
334	60,00	1,44	29,0	1270	5721
271	80,00	0,95	22,0	1270	6297
257	100,00	0,77	18,0	1270	6783

## NRV-P110

$Mn_2$ [Nm]	i	$Pn_1$ [kW]	n2 [rpm]	Fr1 [N]	Fr2 [N]
524	7,50	14,17	233,0	1200	3614
568	10,00	11,64	175,0	1463	3978
623	15,00	8,69	117,0	1604	4554
612	20,00	6,47	88,0	1700	5012
645	25,00	5,52	70,0	1700	5399
689	30,00	5,20	58,0	1700	5737
667	40,00	3,83	44,0	1700	6315
627	50,00	2,99	35,0	1700	6803
585	60,00	2,39	29,0	1700	7229
489	80,00	1,62	22,0	1700	7956
459	100,00	1,29	18,0	1700	8571

## NRV130

$Mn_2$ [Nm]	i	$Pn_1$ [kW]	n2 [rpm]	Fr1 [N]	Fr2 [N]
712	7,50	19,13	233,0	1500	4727
779	10,00	16,04	175,0	1845	5203
874	15,00	12,27	117,0	2070	5956
864	20,00	9,10	88,0	2100	6556
883	25,00	7,62	70,0	2100	7062
988	30,00	7,45	58,0	2100	7504
998	40,00	5,78	44,0	2100	8260
931	50,00	4,49	35,0	2100	8897
855	60,00	3,58	29,0	2100	9455
798	80,00	2,65	22,0	2100	10406
703	100,00	1,98	18,0	2100	11210

## NRV150

$Mn_2$ [Nm]	$i$	$Pn_1$ [kW]	$n_2$ [rpm]	$Fr_1$ [N]	$Fr_2$ [N]
1140	7,50	30,61	233,0	1950	6463
1178	10,00	23,98	175,0	2267	7113
1187	15,00	16,49	117,0	2285	8143
1235	20,00	13,01	88,0	2673	8962
1140	25,00	9,83	70,0	2800	9654
1140	30,00	8,29	58,0	2800	10259
1473	40,00	8,54	44,0	2800	11292
1330	50,00	6,33	35,0	2800	12163
1197	60,00	4,94	29,0	2800	12926
1093	80,00	3,63	22,0	2800	14226
950	100,00	2,68	18,0	2800	15325

## NRV030/040

Mn <sub>2</sub> [Nm]	i	Pn <sub>1</sub> [kW]	n <sub>2</sub> [rpm]	Fr1 [N]	Fr2 [N]
71	100,00	0,20	17,5	169	2769
72	150,00	0,15	11,7	169	3169
65	200,00	0,10	8,8	169	3488
61	250,00	0,08	7,0	169	3490
73	300,00	0,09	5,8	169	3490
65	400,00	0,07	4,4	169	3490
61	500,00	0,05	3,5	179	3490
73	600,00	0,05	2,9	179	3490
73	750,00	0,04	2,3	210	3490
73	900,00	0,04	1,9	210	3490
73	1200,00	0,03	1,5	210	3490
73	1500,00	0,03	1,2	210	3490
73	1800,00	0,02	1,0	210	3490
65	2400,00	0,02	0,7	210	3490
60	3000,00	0,01	0,6	210	3490
48	4000,00	0,01	0,4	210	3490
43	5000,00	0,01	0,4	210	3490

## NRV030/050

Mn <sub>2</sub> [Nm]	i	Pn <sub>1</sub> [kW]	n <sub>2</sub> [rpm]	Fr1 [N]	Fr2 [N]
137	100,00	0,38	17,5	169	3800
135	150,00	0,27	11,7	169	4350
120	200,00	0,19	8,8	169	4788
110	250,00	0,15	7,0	169	4840
145	300,00	0,18	5,8	169	4840
124	400,00	0,13	4,4	169	4840
120	500,00	0,11	3,5	169	4840
145	600,00	0,10	2,9	179	4840
145	750,00	0,09	2,3	210	4840
145	900,00	0,07	1,9	210	4840
145	1200,00	0,06	1,5	210	4840
145	1500,00	0,05	1,2	210	4840
145	1800,00	0,05	1,0	210	4840
124	2400,00	0,03	0,7	210	4840
120	3000,00	0,03	0,6	210	4840
82	4000,00	0,02	0,4	210	4840
79	5000,00	0,01	0,4	210	4840

## NRV-P030/063

$Mn_2$ [Nm]	$i$	$Pn_1$ [kW]	$n_2$ [rpm]	$Fr_1$ [N]	$Fr_2$ [N]
143	100,00	0,40	17,5	169	4967
201	150,00	0,40	11,7	169	5686
253	200,00	0,40	8,8	169	6259
231	250,00	0,30	7,0	169	6270
255	300,00	0,33	5,8	150	6270
255	400,00	0,25	4,4	169	6270
236	500,00	0,20	3,5	169	6270
271	600,00	0,18	2,9	179	6270
271	750,00	0,16	2,3	210	6270
271	900,00	0,14	1,9	210	6270
271	1200,00	0,11	1,5	210	6270
271	1500,00	0,10	1,2	210	6270
271	1800,00	0,09	1,0	210	6270
255	2400,00	0,07	0,7	210	6270
236	3000,00	0,05	0,6	210	6270
236	4000,00	0,05	0,4	210	6270
150	5000,00	0,03	0,4	210	6270

## NRV040/050

$Mn_2$ [Nm]	$i$	$Pn_1$ [kW]	$n_2$ [rpm]	$Fr_1$ [N]	$Fr_2$ [N]
137	100,00	0,37	17,5	343	3800
135	150,00	0,27	11,7	343	4350
120	200,00	0,19	8,8	343	4788
110	250,00	0,15	7,0	343	4840
145	300,00	0,17	5,8	343	4840
124	400,00	0,12	4,4	343	4840
137	500,00	0,10	3,5	350	3800
145	600,00	0,09	2,9	350	4840
145	750,00	0,08	2,3	350	4840
135	900,00	0,06	1,9	350	4350
145	1200,00	0,06	1,5	350	4840
145	1500,00	0,05	1,2	350	4840
145	1800,00	0,04	1,0	350	4840
124	2400,00	0,03	0,7	350	4840
120	3000,00	0,03	0,6	350	4840
120	4000,00	0,02	0,4	350	4840
120	5000,00	0,02	0,4	350	4840

## NRV-P040/063

$Mn_2$ [Nm]	i	$Pn_1$ [kW]	n2 [rpm]	Fr1 [N]	Fr2 [N]
257	100,00	0,70	17,5	343	4967
260	150,00	0,50	11,7	343	5686
253	200,00	0,39	8,8	343	6259
231	250,00	0,30	7,0	343	6270
271	300,00	0,32	5,8	343	6270
255	400,00	0,25	4,4	343	6270
231	500,00	0,16	3,5	350	6270
271	600,00	0,17	2,9	350	6270
271	750,00	0,14	2,3	350	6270
271	900,00	0,13	1,9	350	6270
271	1200,00	0,10	1,5	350	6270
271	1500,00	0,09	1,2	350	6270
271	1800,00	0,08	1,0	350	6270
255	2400,00	0,06	0,7	350	6270
236	3000,00	0,05	0,6	350	6270
236	4000,00	0,04	0,4	350	6270
236	5000,00	0,04	0,4	350	6270

## NRV-P040/075

$Mn_2$ [Nm]	i	$Pn_1$ [kW]	n2 [rpm]	Fr1 [N]	Fr2 [N]
335	100,00	0,90	17,5	343	5863
425	150,00	0,80	11,7	343	6712
420	200,00	0,63	8,8	343	7380
380	250,00	0,47	7,0	343	7380
444	300,00	0,50	5,8	343	7380
414	400,00	0,38	4,4	343	7380
368	500,00	0,29	3,5	343	7380
444	600,00	0,27	2,9	350	7380
444	750,00	0,22	2,3	350	7380
444	900,00	0,20	1,9	350	7380
444	1200,00	0,16	1,5	350	7380
444	1500,00	0,13	1,2	350	7380
444	1800,00	0,12	1,0	350	7380
414	2400,00	0,09	0,7	350	7380
368	3000,00	0,07	0,6	350	7380
368	4000,00	0,06	0,4	350	7380
368	5000,00	0,05	0,4	350	7380



## NRV-P040/090

$Mn_2$ [Nm]	$i$	$Pn_1$ [kW]	$n_2$ [rpm]	$Fr_1$ [N]	$Fr_2$ [N]
343	100,00	0,90	17,5	343	6487
489	150,00	0,90	11,7	343	7426
610	200,00	0,88	8,8	343	8174
570	250,00	0,68	7,0	343	8180
700	300,00	0,75	5,8	343	8180
610	400,00	0,53	4,4	343	8180
560	500,00	0,42	3,5	343	8180
700	600,00	0,40	2,9	350	8180
700	750,00	0,34	2,3	350	8180
700	900,00	0,30	1,9	350	8180
700	1200,00	0,24	1,5	350	8180
700	1500,00	0,20	1,2	350	8180
700	1800,00	0,18	1,0	350	8180
610	2400,00	0,13	0,7	350	8180
560	3000,00	0,10	0,6	350	8180
560	4000,00	0,08	0,4	350	8180
560	5000,00	0,07	0,4	350	8180

## NRV-P050/090

$Mn_2$ [Nm]	$i$	$Pn_1$ [kW]	$n_2$ [rpm]	$Fr_1$ [N]	$Fr_2$ [N]
590	100,00	1,52	17,5	490	6487
660	150,00	1,19	11,7	490	7426
610	200,00	0,86	8,8	490	8174
570	250,00	0,67	7,0	490	8180
700	300,00	0,73	5,8	490	8180
610	400,00	0,52	4,4	490	8180
570	500,00	0,36	3,5	490	8180
700	600,00	0,40	2,9	490	8180
700	750,00	0,33	2,3	490	8180
700	900,00	0,29	1,9	490	8180
700	1200,00	0,23	1,5	490	8180
700	1500,00	0,20	1,2	490	8180
700	1800,00	0,18	1,0	490	8180
610	2400,00	0,13	0,7	490	8180
560	3000,00	0,10	0,6	490	8180
560	4000,00	0,08	0,4	490	8180
560	5000,00	0,07	0,4	490	8180

## NRV-P050/110

$Mn_2$ [Nm]	i	$Pn_1$ [kW]	$n_2$ [rpm]	$Fr_1$ [N]	$Fr_2$ [N]
615	100,00	1,58	17,5	490	8198
889	150,00	1,58	11,7	490	9384
1139	200,00	1,56	8,8	490	10320
1173	250,00	1,32	7,0	490	10320
1265	300,00	1,33	5,8	490	10320
1185	400,00	0,96	4,4	490	10320
1173	500,00	0,72	3,5	490	10320
1265	600,00	0,72	2,9	490	10320
1265	750,00	0,60	2,3	490	10320
1265	900,00	0,53	1,9	490	10320
1265	1200,00	0,42	1,5	490	10320
1265	1500,00	0,36	1,2	490	10320
1265	1800,00	0,32	1,0	490	10320
1185	2400,00	0,23	0,7	490	10320
1100	3000,00	0,18	0,6	490	10320
1100	4000,00	0,15	0,4	490	10320
1100	5000,00	0,13	0,4	490	10320

## NRV-P063/110

$Mn_2$ [Nm]	i	$Pn_1$ [kW]	$n_2$ [rpm]	$Fr_1$ [N]	$Fr_2$ [N]
1027	100,00	2,63	17,5	579	8198
1196	150,00	2,12	11,7	579	9384
1139	200,00	1,55	8,8	579	10320
1173	250,00	1,31	7,0	579	10320
1265	300,00	1,32	5,8	579	10320
1185	400,00	0,96	4,4	579	10320
1173	500,00	0,69	3,5	700	10320
1265	600,00	0,70	2,9	700	10320
1265	750,00	0,58	2,3	700	10320
1265	900,00	0,51	1,9	700	10320
1265	1200,00	0,40	1,5	700	10320
1265	1500,00	0,34	1,2	700	10320
1265	1800,00	0,30	1,0	700	10320
1185	2400,00	0,22	0,7	700	10320
1100	3000,00	0,17	0,6	700	10320
1100	4000,00	0,14	0,4	700	10320
1100	5000,00	0,12	0,4	700	10320

## NRV-P063/130

Mn <sub>2</sub> [Nm]	i	Pn <sub>1</sub> [kW]	n <sub>2</sub> [rpm]	Fr1 [N]	Fr2 [N]
1040	100,00	2,63	17,5	579	10722
1465	150,00	2,63	11,7	579	12274
1600	200,00	2,18	8,8	579	13500
1530	250,00	1,71	7,0	579	13500
1760	300,00	1,81	5,8	579	13500
1650	400,00	1,33	4,4	579	13500
1550	500,00	1,05	3,5	579	13500
1760	600,00	0,96	2,9	700	13500
1760	750,00	0,79	2,3	700	13500
1760	900,00	0,69	1,9	700	13500
1760	1200,00	0,55	1,5	700	13500
1760	1500,00	0,46	1,2	700	13500
1760	1800,00	0,41	1,0	700	13500
1650	2400,00	0,30	0,7	700	13500
1550	3000,00	0,24	0,6	700	13500
1550	4000,00	0,19	0,4	700	13500
1550	5000,00	0,17	0,4	700	13500

## NRV-P063/150

Mn <sub>2</sub> [Nm]	i	Pn <sub>1</sub> [kW]	n <sub>2</sub> [rpm]	Fr1 [N]	Fr2 [N]
1873	150,00	3,32	11,7	500	18000
1929	200,00	2,63	8,8	579	18000
2050	250,00	2,29	7,0	579	18000
2151	300,00	2,02	5,8	646	18000
2670	400,00	2,12	4,4	579	18000
2330	500,00	1,58	3,5	579	18000
2670	600,00	1,46	2,9	646	18000
2330	750,00	1,08	2,3	646	18000
2100	900,00	0,77	1,9	700	18000
2670	1200,00	0,81	1,5	700	18000
2330	1500,00	0,61	1,2	700	18000
2100	1800,00	0,46	1,0	700	18000
2670	2400,00	0,48	0,7	700	18000
2330	3000,00	0,36	0,6	700	18000
2330	4000,00	0,29	0,4	700	18000
2330	5000,00	0,26	0,4	700	18000

## NRV030

Mn <sub>2</sub> [Nm]	i	Pn <sub>1</sub> [kW]	n <sub>2</sub> [rpm]	Fr1 [N]	Fr2 [N]
19	5,00	0,64	280,0	150	597
19	7,50	0,44	187,0	150	683
19	10,00	0,34	140,0	169	752
19	15,00	0,24	93,0	169	861
18	20,00	0,18	70,0	180	948
22	25,00	0,19	56,0	210	1021
21	30,00	0,16	47,0	210	1085
19	40,00	0,12	35,0	210	1194
18	50,00	0,09	28,0	210	1286
16	60,00	0,08	23,0	210	1367
13	80,00	0,05	18,0	210	1504

## NRV040

Mn <sub>2</sub> [Nm]	i	Pn <sub>1</sub> [kW]	n <sub>2</sub> [rpm]	Fr1 [N]	Fr2 [N]
36	5,00	1,19	280,0	250	1149
42	7,50	0,94	187,0	292	1315
44	10,00	0,76	140,0	344	1447
44	15,00	0,52	93,0	344	1657
43	20,00	0,40	70,0	350	1824
39	25,00	0,30	56,0	350	1964
48	30,00	0,33	47,0	350	2087
45	40,00	0,25	35,0	350	2298
42	50,00	0,20	28,0	350	2475
38	60,00	0,16	23,0	350	2630
33	80,00	0,11	18,0	350	2895
29	100,00	0,09	14,0	350	3118

## NRV050

Mn <sub>2</sub> [Nm]	i	Pn <sub>1</sub> [kW]	n <sub>2</sub> [rpm]	Fr1 [N]	Fr2 [N]
68	5,00	2,24	280,0	350	1577
77	7,50	1,71	187,0	396	1805
79	10,00	1,33	140,0	490	1987
81	15,00	0,95	93,0	490	2274
78	20,00	0,71	70,0	490	2503
71	25,00	0,54	56,0	490	2696
88	30,00	0,59	47,0	490	2865
82	40,00	0,44	35,0	490	3153
77	50,00	0,35	28,0	490	3397
72	60,00	0,29	23,0	490	3610

## NRV050

Mn <sub>2</sub> [Nm]	i	Pn <sub>1</sub> [kW]	n <sub>2</sub> [rpm]	Fr1 [N]	Fr2 [N]
65	80,00	0,22	18,0	490	3973
55	100,00	0,16	14,0	490	4280

## NRV-P063

Mn <sub>2</sub> [Nm]	i	Pn <sub>1</sub> [kW]	n <sub>2</sub> [rpm]	Fr1 [N]	Fr2 [N]
128	7,50	2,81	187,0	500	2359
135	10,00	2,28	140,0	595	2597
150	15,00	1,75	93,0	660	2973
146	20,00	1,30	70,0	700	3272
134	25,00	0,99	56,0	700	3524
160	30,00	1,04	47,0	700	3745
149	40,00	0,77	35,0	700	4122
143	50,00	0,63	28,0	700	4440
135	60,00	0,52	23,0	700	4719
122	80,00	0,39	18,0	700	5193
118	100,00	0,33	14,0	700	5595

## NRV-P075

Mn <sub>2</sub> [Nm]	i	Pn <sub>1</sub> [kW]	n <sub>2</sub> [rpm]	Fr1 [N]	Fr2 [N]
185	7,50	4,06	187,0	700	2785
201	10,00	3,35	140,0	857	3065
230	15,00	2,61	93,0	979	3509
236	20,00	2,09	70,0	980	3862
214	25,00	1,55	56,0	980	4160
247	30,00	1,57	47,0	980	4421
245	40,00	1,23	35,0	980	4865
225	50,00	0,94	28,0	980	5241
214	60,00	0,79	23,0	980	5569
195	80,00	0,58	18,0	980	6130
180	100,00	0,47	14,0	980	6603

## NRV-P090

Mn <sub>2</sub> [Nm]	i	Pn <sub>1</sub> [kW]	n <sub>2</sub> [rpm]	Fr1 [N]	Fr2 [N]
319	7,50	6,93	187,0	900	3081
341	10,00	5,62	140,0	1082	3391
396	15,00	4,45	93,0	1257	3882
391	20,00	3,37	70,0	1270	4273

## NRV-P090

$Mn_2$ [Nm]	i	$Pn_1$ [kW]	n2 [rpm]	Fr1 [N]	Fr2 [N]
374	25,00	2,64	56,0	1270	4603
432	30,00	2,67	47,0	1270	4891
396	40,00	1,91	35,0	1270	5383
374	50,00	1,50	28,0	1270	5799
352	60,00	1,23	23,0	1270	6163
285	80,00	0,82	18,0	1270	6783
270	100,00	0,66	14,0	1270	7306

## NRV-P110

$Mn_2$ [Nm]	i	$Pn_1$ [kW]	n2 [rpm]	Fr1 [N]	Fr2 [N]
552	7,50	11,99	187,0	1200	3893
598	10,00	9,85	140,0	1463	4285
656	15,00	7,37	93,0	1604	4905
644	20,00	5,49	70,0	1700	5399
679	25,00	4,68	56,0	1700	5816
725	30,00	4,43	47,0	1700	6181
702	40,00	3,26	35,0	1700	6803
660	50,00	2,55	28,0	1700	7328
616	60,00	2,03	23,0	1700	7787
515	80,00	1,39	18,0	1700	8571
483	100,00	1,11	14,0	1700	9232

## NRV130

$Mn_2$ [Nm]	i	$Pn_1$ [kW]	n2 [rpm]	Fr1 [N]	Fr2 [N]
750	7,50	16,11	187,0	1500	5092
820	10,00	13,51	140,0	1845	5605
920	15,00	10,33	93,0	2070	6416
910	20,00	7,67	70,0	2100	7062
930	25,00	6,42	56,0	2100	7607
1040	30,00	6,27	47,0	2100	8084
1050	40,00	4,87	35,0	2100	8897
980	50,00	3,78	28,0	2100	9584
900	60,00	3,01	23,0	2100	10185
840	80,00	2,23	18,0	2100	11210
740	100,00	1,67	14,0	2100	12076

## NRV150

$Mn_2$ [Nm]	$i$	$Pn_1$ [kW]	$n_2$ [rpm]	$Fr_1$ [N]	$Fr_2$ [N]
1200	7,50	25,78	187,0	1950	6962
1240	10,00	20,20	140,0	2267	7663
1250	15,00	13,88	93,0	2285	8771
1300	20,00	10,95	70,0	2674	9654
1200	25,00	8,28	56,0	2800	10400
1200	30,00	6,98	47,0	2800	11051
1550	40,00	7,19	35,0	2800	12163
1400	50,00	5,33	28,0	2800	13103
1260	60,00	4,16	23,0	2800	13924
1150	80,00	3,05	18,0	2800	15325
1000	100,00	2,26	14,0	2800	16508

## NRV030/040

Mn <sub>2</sub> [Nm]	i	Pn <sub>1</sub> [kW]	n <sub>2</sub> [rpm]	Fr1 [N]	Fr2 [N]
71	100,00	0,16	14,0	169	2769
72	150,00	0,12	9,3	169	3169
65	200,00	0,08	7,0	169	3488
61	250,00	0,07	5,6	169	3490
73	300,00	0,07	4,7	169	3490
65	400,00	0,05	3,5	169	3490
61	500,00	0,04	2,8	180	3490
73	600,00	0,04	2,3	180	3490
73	750,00	0,04	1,9	210	3490
73	900,00	0,03	1,6	210	3490
73	1200,00	0,03	1,2	210	3490
73	1500,00	0,02	0,9	210	3490
73	1800,00	0,02	0,8	210	3490
65	2400,00	0,01	0,6	210	3490
60	3000,00	0,01	0,5	210	3490
48	4000,00	0,01	0,4	210	3490
43	5000,00	0,01	0,3	210	3490

## NRV030/050

Mn <sub>2</sub> [Nm]	i	Pn <sub>1</sub> [kW]	n <sub>2</sub> [rpm]	Fr1 [N]	Fr2 [N]
137	100,00	0,31	14,0	169	3800
135	150,00	0,22	9,3	169	4350
120	200,00	0,15	7,0	169	4788
110	250,00	0,12	5,6	169	4840
145	300,00	0,14	4,7	169	4840
124	400,00	0,10	3,5	169	4840
120	500,00	0,08	2,8	169	4840
145	600,00	0,08	2,3	180	4840
145	750,00	0,07	1,9	210	4840
145	900,00	0,06	1,6	210	4840
145	1200,00	0,05	1,2	210	4840
145	1500,00	0,04	0,9	210	4840
145	1800,00	0,04	0,8	210	4840
124	2400,00	0,03	0,6	210	4840
120	3000,00	0,02	0,5	210	4840
82	4000,00	0,01	0,4	210	4840
79	5000,00	0,01	0,3	210	4840



## NRV-P030/063

$Mn_2$ [Nm]	$i$	$Pn_1$ [kW]	$n_2$ [rpm]	$Fr_1$ [N]	$Fr_2$ [N]
150	100,00	0,34	14,0	169	4967
211	150,00	0,34	9,3	169	5686
253	200,00	0,32	7,0	169	6259
231	250,00	0,24	5,6	169	6270
255	300,00	0,26	4,7	150	6270
255	400,00	0,20	3,5	169	6270
236	500,00	0,16	2,8	169	6270
271	600,00	0,15	2,3	180	6270
271	750,00	0,13	1,9	210	6270
271	900,00	0,11	1,6	210	6270
271	1200,00	0,09	1,2	210	6270
271	1500,00	0,08	0,9	210	6270
271	1800,00	0,07	0,8	210	6270
255	2400,00	0,05	0,6	210	6270
236	3000,00	0,04	0,5	210	6270
236	4000,00	0,04	0,4	210	6270
150	5000,00	0,02	0,3	210	6270

## NRV040/050

$Mn_2$ [Nm]	$i$	$Pn_1$ [kW]	$n_2$ [rpm]	$Fr_1$ [N]	$Fr_2$ [N]
137	100,00	0,30	14,0	344	3800
135	150,00	0,21	9,3	344	4350
120	200,00	0,15	7,0	344	4788
110	250,00	0,12	5,6	344	4840
145	300,00	0,14	4,7	344	4840
124	400,00	0,10	3,5	344	4840
137	500,00	0,08	2,8	350	3800
145	600,00	0,07	2,3	350	4840
145	750,00	0,06	1,9	350	4840
135	900,00	0,05	1,6	350	4350
145	1200,00	0,04	1,2	350	4840
145	1500,00	0,04	0,9	350	4840
145	1800,00	0,03	0,8	350	4840
124	2400,00	0,02	0,6	350	4840
120	3000,00	0,02	0,5	350	4840
120	4000,00	0,02	0,4	350	4840
120	5000,00	0,01	0,3	350	4840

## NRV-P040/063

$Mn_2$ [Nm]	i	$Pn_1$ [kW]	n2 [rpm]	Fr1 [N]	Fr2 [N]
257	100,00	0,56	14,0	344	4967
260	150,00	0,40	9,3	344	5686
253	200,00	0,31	7,0	344	6259
231	250,00	0,24	5,6	344	6270
271	300,00	0,26	4,7	344	6270
255	400,00	0,20	3,5	344	6270
231	500,00	0,13	2,8	350	6270
271	600,00	0,14	2,3	350	6270
271	750,00	0,11	1,9	350	6270
271	900,00	0,10	1,6	350	6270
271	1200,00	0,08	1,2	350	6270
271	1500,00	0,07	0,9	350	6270
271	1800,00	0,06	0,8	350	6270
255	2400,00	0,05	0,6	350	6270
236	3000,00	0,04	0,5	350	6270
236	4000,00	0,03	0,4	350	6270
236	5000,00	0,03	0,3	350	6270

## NRV-P040/075

$Mn_2$ [Nm]	i	$Pn_1$ [kW]	n2 [rpm]	Fr1 [N]	Fr2 [N]
352	100,00	0,76	14,0	344	5863
425	150,00	0,64	9,3	344	6712
420	200,00	0,50	7,0	344	7380
380	250,00	0,38	5,6	344	7380
444	300,00	0,40	4,7	344	7380
414	400,00	0,30	3,5	344	7380
368	500,00	0,24	2,8	344	7380
444	600,00	0,21	2,3	350	7380
444	750,00	0,18	1,9	350	7380
444	900,00	0,16	1,6	350	7380
444	1200,00	0,13	1,2	350	7380
444	1500,00	0,11	0,9	350	7380
444	1800,00	0,10	0,8	350	7380
414	2400,00	0,07	0,6	350	7380
368	3000,00	0,06	0,5	350	7380
368	4000,00	0,05	0,4	350	7380
368	5000,00	0,04	0,3	350	7380

## NRV-P040/090

$Mn_2$ [Nm]	$i$	$Pn_1$ [kW]	$n_2$ [rpm]	$Fr_1$ [N]	$Fr_2$ [N]
361	100,00	0,76	14,0	344	6487
515	150,00	0,76	9,3	344	7426
610	200,00	0,70	7,0	344	8174
570	250,00	0,55	5,6	344	8180
700	300,00	0,60	4,7	344	8180
610	400,00	0,42	3,5	344	8180
560	500,00	0,33	2,8	344	8180
700	600,00	0,32	2,3	350	8180
700	750,00	0,27	1,9	350	8180
700	900,00	0,24	1,6	350	8180
700	1200,00	0,19	1,2	350	8180
700	1500,00	0,16	0,9	350	8180
700	1800,00	0,14	0,8	350	8180
610	2400,00	0,10	0,6	350	8180
560	3000,00	0,08	0,5	350	8180
560	4000,00	0,07	0,4	350	8180
560	5000,00	0,06	0,3	350	8180

## NRV-P050/090

$Mn_2$ [Nm]	$i$	$Pn_1$ [kW]	$n_2$ [rpm]	$Fr_1$ [N]	$Fr_2$ [N]
590	100,00	1,21	14,0	490	6487
660	150,00	0,95	9,3	490	7426
610	200,00	0,69	7,0	490	8174
570	250,00	0,53	5,6	490	8180
700	300,00	0,59	4,7	490	8180
610	400,00	0,41	3,5	490	8180
570	500,00	0,29	2,8	490	8180
700	600,00	0,32	2,3	490	8180
700	750,00	0,27	1,9	490	8180
700	900,00	0,23	1,6	490	8180
700	1200,00	0,19	1,2	490	8180
700	1500,00	0,16	0,9	490	8180
700	1800,00	0,14	0,8	490	8180
610	2400,00	0,10	0,6	490	8180
560	3000,00	0,08	0,5	490	8180
560	4000,00	0,07	0,4	490	8180
560	5000,00	0,06	0,3	490	8180

## NRV-P050/110

Mn <sub>2</sub> [Nm]	i	Pn <sub>1</sub> [kW]	n <sub>2</sub> [rpm]	Fr1 [N]	Fr2 [N]
648	100,00	1,33	14,0	490	8198
936	150,00	1,33	9,3	490	9384
1139	200,00	1,25	7,0	490	10320
1173	250,00	1,05	5,6	490	10320
1265	300,00	1,06	4,7	490	10320
1185	400,00	0,77	3,5	490	10320
1173	500,00	0,57	2,8	490	10320
1265	600,00	0,58	2,3	490	10320
1265	750,00	0,48	1,9	490	10320
1265	900,00	0,42	1,6	490	10320
1265	1200,00	0,34	1,2	490	10320
1265	1500,00	0,29	0,9	490	10320
1265	1800,00	0,26	0,8	490	10320
1185	2400,00	0,19	0,6	490	10320
1100	3000,00	0,14	0,5	490	10320
1100	4000,00	0,12	0,4	490	10320
1100	5000,00	0,10	0,3	490	10320

## NRV-P063/110

Mn <sub>2</sub> [Nm]	i	Pn <sub>1</sub> [kW]	n <sub>2</sub> [rpm]	Fr1 [N]	Fr2 [N]
1110	100,00	2,28	14,0	595	8198
1196	150,00	1,70	9,3	595	9384
1139	200,00	1,25	7,0	595	10320
1173	250,00	1,05	5,6	595	10320
1265	300,00	1,06	4,7	595	10320
1185	400,00	0,77	3,5	595	10320
1173	500,00	0,56	2,8	700	10320
1265	600,00	0,56	2,3	700	10320
1265	750,00	0,47	1,9	700	10320
1265	900,00	0,41	1,6	700	10320
1265	1200,00	0,32	1,2	700	10320
1265	1500,00	0,28	0,9	700	10320
1265	1800,00	0,24	0,8	700	10320
1185	2400,00	0,18	0,6	700	10320
1100	3000,00	0,14	0,5	700	10320
1100	4000,00	0,11	0,4	700	10320
1100	5000,00	0,10	0,3	700	10320

## NRV-P063/130

Mn <sub>2</sub> [Nm]	i	Pn <sub>1</sub> [kW]	n <sub>2</sub> [rpm]	Fr1 [N]	Fr2 [N]
1123	100,00	2,28	14,0	595	10722
1584	150,00	2,28	9,3	595	12274
1600	200,00	1,75	7,0	595	13500
1530	250,00	1,37	5,6	595	13500
1760	300,00	1,45	4,7	595	13500
1650	400,00	1,07	3,5	595	13500
1550	500,00	0,84	2,8	595	13500
1760	600,00	0,77	2,3	700	13500
1760	750,00	0,64	1,9	700	13500
1760	900,00	0,56	1,6	700	13500
1760	1200,00	0,45	1,2	700	13500
1760	1500,00	0,38	0,9	700	13500
1760	1800,00	0,33	0,8	700	13500
1650	2400,00	0,25	0,6	700	13500
1550	3000,00	0,19	0,5	700	13500
1550	4000,00	0,16	0,4	700	13500
1550	5000,00	0,14	0,3	700	13500

## NRV-P063/150

Mn <sub>2</sub> [Nm]	i	Pn <sub>1</sub> [kW]	n <sub>2</sub> [rpm]	Fr1 [N]	Fr2 [N]
1971	150,00	2,81	9,3	500	18000
2084	200,00	2,28	7,0	595	18000
2050	250,00	1,84	5,6	595	18000
2312	300,00	1,75	4,7	660	18000
2670	400,00	1,70	3,5	595	18000
2330	500,00	1,27	2,8	595	18000
2670	600,00	1,18	2,3	660	18000
2330	750,00	0,87	1,9	660	18000
2100	900,00	0,62	1,6	700	18000
2670	1200,00	0,66	1,2	700	18000
2330	1500,00	0,49	0,9	700	18000
2100	1800,00	0,37	0,8	700	18000
2670	2400,00	0,39	0,6	700	18000
2330	3000,00	0,29	0,5	700	18000
2330	4000,00	0,24	0,4	700	18000
2330	5000,00	0,21	0,3	700	18000

## NRV030

$Mn_2$ [Nm]	$i$	$Pn_1$ [kW]	$n_2$ [rpm]	$Fr_1$ [N]	$Fr_2$ [N]
20	5,00	0,56	228,0	175	639
20	7,50	0,38	152,0	175	732
20	10,00	0,29	114,0	197	805
20	15,00	0,21	76,0	197	922
19	20,00	0,16	57,0	210	1015
23	25,00	0,16	46,0	210	1093
21	30,00	0,13	38,0	210	1162
20	40,00	0,10	29,0	210	1278
19	50,00	0,08	23,0	210	1377
17	60,00	0,07	19,0	210	1463
14	80,00	0,05	14,0	210	1611

## NRV040

$Mn_2$ [Nm]	$i$	$Pn_1$ [kW]	$n_2$ [rpm]	$Fr_1$ [N]	$Fr_2$ [N]
39	5,00	1,06	228,0	290	1230
44	7,50	0,81	152,0	327	1408
46	10,00	0,65	114,0	350	1550
47	15,00	0,46	76,0	350	1774
46	20,00	0,35	57,0	350	1953
42	25,00	0,27	46,0	350	2104
51	30,00	0,29	38,0	350	2235
48	40,00	0,22	29,0	350	2460
44	50,00	0,17	23,0	350	2650
40	60,00	0,14	19,0	350	2816
34	80,00	0,10	14,0	350	3100
31	100,00	0,08	11,0	350	3339

## NRV050

$Mn_2$ [Nm]	$i$	$Pn_1$ [kW]	$n_2$ [rpm]	$Fr_1$ [N]	$Fr_2$ [N]
75	5,00	2,01	228,0	400	1689
84	7,50	1,54	152,0	448	1933
86	10,00	1,19	114,0	490	2127
86	15,00	0,84	76,0	490	2435
80	20,00	0,61	57,0	490	2680
73	25,00	0,46	46,0	490	2887
91	30,00	0,51	38,0	490	3068
85	40,00	0,38	29,0	490	3377
79	50,00	0,30	23,0	490	3638
74	60,00	0,25	19,0	490	3866

## NRV050

$Mn_2$ [Nm]	i	$Pn_1$ [kW]	$n_2$ [rpm]	$Fr_1$ [N]	$Fr_2$ [N]
66	80,00	0,19	14,0	490	4255
55	100,00	0,14	11,0	490	4583

## NRV-P063

$Mn_2$ [Nm]	i	$Pn_1$ [kW]	$n_2$ [rpm]	$Fr_1$ [N]	$Fr_2$ [N]
139	7,50	2,51	152,0	580	2527
143	10,00	1,97	114,0	667	2781
159	15,00	1,52	76,0	700	3183
154	20,00	1,14	57,0	700	3504
141	25,00	0,87	46,0	700	3774
168	30,00	0,91	38,0	700	4011
160	40,00	0,69	29,0	700	4414
152	50,00	0,56	23,0	700	4755
144	60,00	0,47	19,0	700	5053
129	80,00	0,34	14,0	700	5562
121	100,00	0,29	11,0	700	5991

## NRV-P075

$Mn_2$ [Nm]	i	$Pn_1$ [kW]	$n_2$ [rpm]	$Fr_1$ [N]	$Fr_2$ [N]
200	7,50	3,59	152,0	810	2982
212	10,00	2,92	114,0	968	3282
250	15,00	2,36	76,0	980	3757
250	20,00	1,84	57,0	980	4135
228	25,00	1,38	46,0	980	4455
264	30,00	1,41	38,0	980	4734
262	40,00	1,11	29,0	980	5210
240	50,00	0,86	23,0	980	5613
231	60,00	0,73	19,0	980	5964
207	80,00	0,54	14,0	980	6565
188	100,00	0,43	11,0	980	7071

## NRV-P090

$Mn_2$ [Nm]	i	$Pn_1$ [kW]	$n_2$ [rpm]	$Fr_1$ [N]	$Fr_2$ [N]
347	7,50	6,16	152,0	1040	3300
374	10,00	5,06	114,0	1270	3632
429	15,00	3,96	76,0	1270	4157
410	20,00	2,92	57,0	1270	4576

## NRV-P090

$Mn_2$ [Nm]	$i$	$Pn_1$ [kW]	$n_2$ [rpm]	$Fr_1$ [N]	$Fr_2$ [N]
390	25,00	2,28	46,0	1270	4929
459	30,00	2,35	38,0	1270	5238
423	40,00	1,70	29,0	1270	5765
402	50,00	1,34	23,0	1270	6210
369	60,00	1,08	19,0	1270	6599
300	80,00	0,72	14,0	1270	7264
275	100,00	0,57	11,0	1270	7824

## NRV-P110

$Mn_2$ [Nm]	$i$	$Pn_1$ [kW]	$n_2$ [rpm]	$Fr_1$ [N]	$Fr_2$ [N]
601	7,50	10,68	152,0	1390	4169
656	10,00	8,83	114,0	1700	4589
707	15,00	6,50	76,0	1700	5253
685	20,00	4,80	57,0	1700	5782
719	25,00	4,10	46,0	1700	6228
783	30,00	3,95	38,0	1700	6619
748	40,00	2,88	29,0	1700	7285
704	50,00	2,26	23,0	1700	7847
649	60,00	1,79	19,0	1700	8339
541	80,00	1,22	14,0	1700	9178
499	100,00	0,96	11,0	1700	9887

## NRV130

$Mn_2$ [Nm]	$i$	$Pn_1$ [kW]	$n_2$ [rpm]	$Fr_1$ [N]	$Fr_2$ [N]
815	7,50	14,41	152,0	1740	5453
890	10,00	12,07	114,0	2100	6002
990	15,00	9,27	76,0	2100	6871
975	20,00	6,85	57,0	2100	7562
990	25,00	5,70	46,0	2100	8146
1105	30,00	5,57	38,0	2100	8657
1075	40,00	4,22	29,0	2100	9528
1015	50,00	3,32	23,0	2100	10264
920	60,00	2,61	19,0	2100	10907
850	80,00	1,95	14,0	2100	12005
760	100,00	1,51	11,0	2100	12931



## NRV150

$Mn_2$ [Nm]	$i$	$Pn_1$ [kW]	$n_2$ [rpm]	$Fr_1$ [N]	$Fr_2$ [N]
1400	7,50	24,76	152,0	2270	7455
1480	10,00	19,85	114,0	2700	8206
1450	15,00	13,26	76,0	2645	9393
1500	20,00	10,53	57,0	2800	10338
1380	25,00	7,84	46,0	2800	11137
1400	30,00	6,79	38,0	2800	11835
1800	40,00	7,07	29,0	2800	13026
1600	50,00	5,16	23,0	2800	14031
1440	60,00	4,04	19,0	2800	14911
1300	80,00	2,94	14,0	2800	16411
1150	100,00	2,25	11,0	2800	17679

## NRV030/040

Mn <sub>2</sub> [Nm]	i	Pn <sub>1</sub> [kW]	n <sub>2</sub> [rpm]	Fr1 [N]	Fr2 [N]
71	100,00	0,13	11,4	197	2769
72	150,00	0,10	7,6	197	3169
65	200,00	0,07	5,7	197	3488
61	250,00	0,05	4,6	197	3490
73	300,00	0,06	3,8	197	3490
65	400,00	0,04	2,9	197	3490
61	500,00	0,03	2,3	210	3490
73	600,00	0,03	1,9	210	3490
73	750,00	0,03	1,5	210	3490
73	900,00	0,03	1,3	210	3490
73	1200,00	0,02	1,0	210	3490
73	1500,00	0,02	0,8	210	3490
73	1800,00	0,02	0,6	210	3490
65	2400,00	0,01	0,5	210	3490
60	3000,00	0,01	0,4	210	3490
48	4000,00	0,01	0,3	210	3490
43	5000,00	0,01	0,2	210	3490

## NRV030/050

Mn <sub>2</sub> [Nm]	i	Pn <sub>1</sub> [kW]	n <sub>2</sub> [rpm]	Fr1 [N]	Fr2 [N]
137	100,00	0,25	11,4	197	3800
135	150,00	0,18	7,6	197	4350
120	200,00	0,13	5,7	197	4788
110	250,00	0,10	4,6	197	4840
145	300,00	0,12	3,8	197	4840
124	400,00	0,08	2,9	197	4840
120	500,00	0,07	2,3	197	4840
145	600,00	0,07	1,9	210	4840
145	750,00	0,06	1,5	210	4840
145	900,00	0,05	1,3	210	4840
145	1200,00	0,04	1,0	210	4840
145	1500,00	0,04	0,8	210	4840
145	1800,00	0,03	0,6	210	4840
124	2400,00	0,02	0,5	210	4840
120	3000,00	0,02	0,4	210	4840
82	4000,00	0,01	0,3	210	4840
79	5000,00	0,01	0,2	210	4840

## NRV-P030/063

$Mn_2$ [Nm]	$i$	$Pn_1$ [kW]	$n_2$ [rpm]	$Fr_1$ [N]	$Fr_2$ [N]
158	100,00	0,29	11,4	197	4967
222	150,00	0,29	7,6	197	5686
253	200,00	0,26	5,7	197	6259
231	250,00	0,20	4,6	197	6270
255	300,00	0,22	3,8	175	6270
255	400,00	0,17	2,9	197	6270
236	500,00	0,13	2,3	197	6270
271	600,00	0,12	1,9	210	6270
271	750,00	0,11	1,5	210	6270
271	900,00	0,09	1,3	210	6270
271	1200,00	0,08	1,0	210	6270
271	1500,00	0,07	0,8	210	6270
271	1800,00	0,06	0,6	210	6270
255	2400,00	0,04	0,5	210	6270
236	3000,00	0,04	0,4	210	6270
236	4000,00	0,03	0,3	210	6270
150	5000,00	0,02	0,2	210	6270

## NRV040/050

$Mn_2$ [Nm]	$i$	$Pn_1$ [kW]	$n_2$ [rpm]	$Fr_1$ [N]	$Fr_2$ [N]
137	100,00	0,25	11,4	350	3800
135	150,00	0,18	7,6	350	4350
120	200,00	0,12	5,7	350	4788
110	250,00	0,10	4,6	350	4840
145	300,00	0,11	3,8	350	4840
124	400,00	0,08	2,9	350	4840
137	500,00	0,07	2,3	350	3800
145	600,00	0,06	1,9	350	4840
145	750,00	0,05	1,5	350	4840
135	900,00	0,04	1,3	350	4350
145	1200,00	0,04	1,0	350	4840
145	1500,00	0,03	0,8	350	4840
145	1800,00	0,03	0,6	350	4840
124	2400,00	0,02	0,5	350	4840
120	3000,00	0,02	0,4	350	4840
120	4000,00	0,01	0,3	350	4840
120	5000,00	0,01	0,2	350	4840

## NRV-P040/063

$Mn_2$ [Nm]	$i$	$Pn_1$ [kW]	$n_2$ [rpm]	$Fr_1$ [N]	$Fr_2$ [N]
257	100,00	0,46	11,4	350	4967
260	150,00	0,33	7,6	350	5686
253	200,00	0,26	5,7	350	6259
231	250,00	0,20	4,6	350	6270
271	300,00	0,21	3,8	350	6270
255	400,00	0,16	2,9	350	6270
231	500,00	0,11	2,3	350	6270
271	600,00	0,11	1,9	350	6270
271	750,00	0,09	1,5	350	6270
271	900,00	0,09	1,3	350	6270
271	1200,00	0,07	1,0	350	6270
271	1500,00	0,06	0,8	350	6270
271	1800,00	0,05	0,6	350	6270
255	2400,00	0,04	0,5	350	6270
236	3000,00	0,03	0,4	350	6270
236	4000,00	0,03	0,3	350	6270
236	5000,00	0,02	0,2	350	6270

## NRV-P040/075

$Mn_2$ [Nm]	$i$	$Pn_1$ [kW]	$n_2$ [rpm]	$Fr_1$ [N]	$Fr_2$ [N]
368	100,00	0,65	11,4	350	5863
425	150,00	0,53	7,6	350	6712
420	200,00	0,41	5,7	350	7380
380	250,00	0,31	4,6	350	7380
444	300,00	0,33	3,8	350	7380
414	400,00	0,25	2,9	350	7380
368	500,00	0,19	2,3	350	7380
444	600,00	0,18	1,9	350	7380
444	750,00	0,15	1,5	350	7380
444	900,00	0,13	1,3	350	7380
444	1200,00	0,11	1,0	350	7380
444	1500,00	0,09	0,8	350	7380
444	1800,00	0,08	0,6	350	7380
414	2400,00	0,06	0,5	350	7380
368	3000,00	0,05	0,4	350	7380
368	4000,00	0,04	0,3	350	7380
368	5000,00	0,04	0,2	350	7380

## NRV-P040/090

Mn <sub>2</sub> [Nm]	i	Pn <sub>1</sub> [kW]	n <sub>2</sub> [rpm]	Fr1 [N]	Fr2 [N]
377	100,00	0,65	11,4	350	6487
538	150,00	0,65	7,6	350	7426
610	200,00	0,58	5,7	350	8174
570	250,00	0,45	4,6	350	8180
700	300,00	0,49	3,8	350	8180
610	400,00	0,35	2,9	350	8180
560	500,00	0,27	2,3	350	8180
700	600,00	0,27	1,9	350	8180
700	750,00	0,22	1,5	350	8180
700	900,00	0,20	1,3	350	8180
700	1200,00	0,16	1,0	350	8180
700	1500,00	0,14	0,8	350	8180
700	1800,00	0,12	0,6	350	8180
610	2400,00	0,09	0,5	350	8180
560	3000,00	0,07	0,4	350	8180
560	4000,00	0,06	0,3	350	8180
560	5000,00	0,05	0,2	350	8180

## NRV-P050/090

Mn <sub>2</sub> [Nm]	i	Pn <sub>1</sub> [kW]	n <sub>2</sub> [rpm]	Fr1 [N]	Fr2 [N]
590	100,00	1,00	11,4	490	6487
660	150,00	0,78	7,6	490	7426
610	200,00	0,56	5,7	490	8174
570	250,00	0,44	4,6	490	8180
700	300,00	0,48	3,8	490	8180
610	400,00	0,34	2,9	490	8180
570	500,00	0,24	2,3	490	8180
700	600,00	0,26	1,9	490	8180
700	750,00	0,22	1,5	490	8180
700	900,00	0,20	1,3	490	8180
700	1200,00	0,16	1,0	490	8180
700	1500,00	0,13	0,8	490	8180
700	1800,00	0,12	0,6	490	8180
610	2400,00	0,08	0,5	490	8180
560	3000,00	0,07	0,4	490	8180
560	4000,00	0,06	0,3	490	8180
560	5000,00	0,05	0,2	490	8180

## NRV-P050/110

$Mn_2$ [Nm]	i	$Pn_1$ [kW]	n2 [rpm]	Fr1 [N]	Fr2 [N]
702	100,00	1,19	11,4	490	8198
1014	150,00	1,19	7,6	490	9384
1139	200,00	1,03	5,7	490	10320
1173	250,00	0,87	4,6	490	10320
1265	300,00	0,87	3,8	490	10320
1185	400,00	0,63	2,9	490	10320
1173	500,00	0,47	2,3	490	10320
1265	600,00	0,48	1,9	490	10320
1265	750,00	0,40	1,5	490	10320
1265	900,00	0,35	1,3	490	10320
1265	1200,00	0,28	1,0	490	10320
1265	1500,00	0,24	0,8	490	10320
1265	1800,00	0,22	0,6	490	10320
1185	2400,00	0,16	0,5	490	10320
1100	3000,00	0,12	0,4	490	10320
1100	4000,00	0,10	0,3	490	10320
1100	5000,00	0,09	0,2	490	10320

## NRV-P063/110

$Mn_2$ [Nm]	i	$Pn_1$ [kW]	n2 [rpm]	Fr1 [N]	Fr2 [N]
1127	100,00	1,90	11,4	667	8198
1196	150,00	1,40	7,6	667	9384
1139	200,00	1,02	5,7	667	10320
1173	250,00	0,87	4,6	667	10320
1265	300,00	0,87	3,8	667	10320
1185	400,00	0,63	2,9	667	10320
1173	500,00	0,46	2,3	700	10320
1265	600,00	0,47	1,9	700	10320
1265	750,00	0,39	1,5	700	10320
1265	900,00	0,34	1,3	700	10320
1265	1200,00	0,27	1,0	700	10320
1265	1500,00	0,23	0,8	700	10320
1265	1800,00	0,20	0,6	700	10320
1185	2400,00	0,15	0,5	700	10320
1100	3000,00	0,11	0,4	700	10320
1100	4000,00	0,09	0,3	700	10320
1100	5000,00	0,08	0,2	700	10320

## NRV-P063/130

Mn <sub>2</sub> [Nm]	i	Pn <sub>1</sub> [kW]	n <sub>2</sub> [rpm]	Fr1 [N]	Fr2 [N]
1183	100,00	1,97	11,4	667	10722
1668	150,00	1,97	7,6	667	12274
1600	200,00	1,44	5,7	667	13500
1530	250,00	1,13	4,6	667	13500
1760	300,00	1,19	3,8	667	13500
1650	400,00	0,88	2,9	667	13500
1550	500,00	0,69	2,3	667	13500
1760	600,00	0,64	1,9	700	13500
1760	750,00	0,53	1,5	700	13500
1760	900,00	0,47	1,3	700	13500
1760	1200,00	0,37	1,0	700	13500
1760	1500,00	0,32	0,8	700	13500
1760	1800,00	0,28	0,6	700	13500
1650	2400,00	0,21	0,5	700	13500
1550	3000,00	0,16	0,4	700	13500
1550	4000,00	0,13	0,3	700	13500
1550	5000,00	0,12	0,2	700	13500

## NRV-P063/150

Mn <sub>2</sub> [Nm]	i	Pn <sub>1</sub> [kW]	n <sub>2</sub> [rpm]	Fr1 [N]	Fr2 [N]
2148	150,00	2,51	7,6	580	18000
2195	200,00	1,97	5,7	667	18000
2050	250,00	1,51	4,6	667	18000
2340	300,00	1,45	3,8	700	18000
2670	400,00	1,40	2,9	667	18000
2330	500,00	1,04	2,3	667	18000
2670	600,00	0,97	1,9	700	18000
2330	750,00	0,72	1,5	700	18000
2100	900,00	0,52	1,3	700	18000
2670	1200,00	0,55	1,0	700	18000
2330	1500,00	0,41	0,8	700	18000
2100	1800,00	0,31	0,6	700	18000
2670	2400,00	0,33	0,5	700	18000
2330	3000,00	0,24	0,4	700	18000
2330	4000,00	0,20	0,3	700	18000
2330	5000,00	0,18	0,2	700	18000

## NRV030

$Mn_2$ [Nm]	$i$	$Pn_1$ [kW]	$n_2$ [rpm]	$Fr_1$ [N]	$Fr_2$ [N]
21	5,00	0,47	180,0	175	692
21	7,50	0,32	120,0	175	792
21	10,00	0,24	90,0	197	871
21	15,00	0,18	60,0	197	997
20	20,00	0,13	45,0	210	1098
24	25,00	0,14	36,0	210	1183
22	30,00	0,11	30,0	210	1257
21	40,00	0,09	23,0	210	1383
19	50,00	0,07	18,0	210	1490
17	60,00	0,06	15,0	210	1583
15	80,00	0,04	11,0	210	1743

## NRV040

$Mn_2$ [Nm]	$i$	$Pn_1$ [kW]	$n_2$ [rpm]	$Fr_1$ [N]	$Fr_2$ [N]
42	5,00	0,91	180,0	290	1331
46	7,50	0,68	120,0	318	1524
48	10,00	0,55	90,0	350	1677
50	15,00	0,40	60,0	350	1920
48	20,00	0,30	45,0	350	2113
45	25,00	0,23	36,0	350	2276
53	30,00	0,25	30,0	350	2419
50	40,00	0,19	23,0	350	2662
46	50,00	0,15	18,0	350	2868
41	60,00	0,12	15,0	350	3047
35	80,00	0,08	11,0	350	3354
32	100,00	0,07	9,0	350	3490

## NRV050

$Mn_2$ [Nm]	$i$	$Pn_1$ [kW]	$n_2$ [rpm]	$Fr_1$ [N]	$Fr_2$ [N]
82	5,00	1,76	180,0	400	1827
91	7,50	1,33	120,0	444	2091
92	10,00	1,02	90,0	490	2302
92	15,00	0,72	60,0	490	2635
83	20,00	0,51	45,0	490	2900
76	25,00	0,39	36,0	490	3124
94	30,00	0,43	30,0	490	3320
88	40,00	0,32	23,0	490	3654
81	50,00	0,25	18,0	490	3936
76	60,00	0,21	15,0	490	4183



## NRV050

$Mn_2$ [Nm]	i	$Pn_1$ [kW]	n2 [rpm]	Fr1 [N]	Fr2 [N]
68	80,00	0,16	11,0	490	4604
56	100,00	0,12	9,0	490	4840

## NRV-P063

$Mn_2$ [Nm]	i	$Pn_1$ [kW]	n2 [rpm]	Fr1 [N]	Fr2 [N]
151	7,50	2,16	120,0	580	2734
153	10,00	1,70	90,0	661	3009
171	15,00	1,31	60,0	700	3444
163	20,00	0,99	45,0	700	3791
149	25,00	0,74	36,0	700	4084
177	30,00	0,78	30,0	700	4339
171	40,00	0,61	23,0	700	4776
161	50,00	0,49	18,0	700	5145
153	60,00	0,41	15,0	700	5467
137	80,00	0,30	11,0	700	6018
124	100,00	0,24	9,0	700	6270

## NRV-P075

$Mn_2$ [Nm]	i	$Pn_1$ [kW]	n2 [rpm]	Fr1 [N]	Fr2 [N]
215	7,50	3,07	120,0	810	3227
230	10,00	2,52	90,0	975	3551
264	15,00	2,00	60,0	980	4065
268	20,00	1,58	45,0	980	4474
241	25,00	1,16	36,0	980	4820
285	30,00	1,21	30,0	980	5122
277	40,00	0,95	23,0	980	5637
255	50,00	0,75	18,0	980	6073
247	60,00	0,63	15,0	980	6453
220	80,00	0,46	11,0	980	7103
196	100,00	0,36	9,0	980	7380

## NRV-P090

$Mn_2$ [Nm]	i	$Pn_1$ [kW]	n2 [rpm]	Fr1 [N]	Fr2 [N]
374	7,50	5,28	120,0	1040	3570
407	10,00	4,41	90,0	1270	3929
462	15,00	3,41	60,0	1270	4498
429	20,00	2,47	45,0	1270	4951

## NRV-P090

$Mn_2$ [Nm]	$i$	$Pn_1$ [kW]	$n_2$ [rpm]	$Fr_1$ [N]	$Fr_2$ [N]
407	25,00	1,92	36,0	1270	5333
485	30,00	2,00	30,0	1270	5667
451	40,00	1,48	23,0	1270	6238
429	50,00	1,17	18,0	1270	6719
385	60,00	0,93	15,0	1270	7140
315	80,00	0,62	11,0	1270	7859
280	100,00	0,48	9,0	1270	8180

## NRV-P110

$Mn_2$ [Nm]	$i$	$Pn_1$ [kW]	$n_2$ [rpm]	$Fr_1$ [N]	$Fr_2$ [N]
650	7,50	9,18	120,0	1390	4511
713	10,00	7,64	90,0	1700	4965
759	15,00	5,54	60,0	1700	5684
725	20,00	4,07	45,0	1700	6256
759	25,00	3,49	36,0	1700	6739
840	30,00	3,43	30,0	1700	7161
794	40,00	2,49	23,0	1700	7882
748	50,00	1,96	18,0	1700	8491
682	60,00	1,55	15,0	1700	9023
567	80,00	1,04	11,0	1700	9931
515	100,00	0,82	9,0	1700	10320

## NRV130

$Mn_2$ [Nm]	$i$	$Pn_1$ [kW]	$n_2$ [rpm]	$Fr_1$ [N]	$Fr_2$ [N]
880	7,50	12,29	120,0	1740	5901
960	10,00	10,28	90,0	2100	6494
1060	15,00	7,83	60,0	2100	7434
1040	20,00	5,77	45,0	2100	8182
1050	25,00	4,77	36,0	2100	8814
1170	30,00	4,65	30,0	2100	9366
1100	40,00	3,41	23,0	2100	10309
1050	50,00	2,71	18,0	2100	11105
940	60,00	2,11	15,0	2100	11801
860	80,00	1,56	11,0	2100	12989
780	100,00	1,23	9,0	2100	13500

## NRV150

$Mn_2$ [Nm]	$i$	$Pn_1$ [kW]	$n_2$ [rpm]	$Fr_1$ [N]	$Fr_2$ [N]
1400	7,50	19,55	120,0	2270	8067
1480	10,00	15,67	90,0	2700	8878
1450	15,00	10,47	60,0	2645	10163
1500	20,00	8,32	45,0	2800	11186
1380	25,00	6,19	36,0	2800	12050
1400	30,00	5,36	30,0	2800	12805
1800	40,00	5,58	23,0	2800	14094
1600	50,00	4,08	18,0	2800	15182
1440	60,00	3,19	15,0	2800	16133
1300	80,00	2,32	11,0	2800	17757
1150	100,00	1,78	9,0	2800	18000

## NRV030/040

Mn <sub>2</sub> [Nm]	i	Pn <sub>1</sub> [kW]	n <sub>2</sub> [rpm]	Fr1 [N]	Fr2 [N]
71	100,00	0,11	9,0	197	2769
72	150,00	0,08	6,0	197	3169
65	200,00	0,05	4,5	197	3488
61	250,00	0,04	3,6	197	3490
73	300,00	0,05	3,0	197	3490
65	400,00	0,04	2,3	197	3490
61	500,00	0,03	1,8	210	3490
73	600,00	0,03	1,5	210	3490
73	750,00	0,02	1,2	210	3490
73	900,00	0,02	1,0	210	3490
73	1200,00	0,02	0,8	210	3490
73	1500,00	0,01	0,6	210	3490
73	1800,00	0,01	0,5	210	3490
65	2400,00	0,01	0,4	210	3490
60	3000,00	0,01	0,3	210	3490
48	4000,00	0,01	0,2	210	3490
43	5000,00	0,00	0,2	210	3490

## NRV030/050

Mn <sub>2</sub> [Nm]	i	Pn <sub>1</sub> [kW]	n <sub>2</sub> [rpm]	Fr1 [N]	Fr2 [N]
137	100,00	0,20	9,0	197	3800
135	150,00	0,14	6,0	197	4350
120	200,00	0,10	4,5	197	4788
110	250,00	0,08	3,6	197	4840
145	300,00	0,09	3,0	197	4840
124	400,00	0,07	2,3	197	4840
120	500,00	0,06	1,8	197	4840
145	600,00	0,05	1,5	210	4840
145	750,00	0,05	1,2	210	4840
145	900,00	0,04	1,0	210	4840
145	1200,00	0,03	0,8	210	4840
145	1500,00	0,03	0,6	210	4840
145	1800,00	0,03	0,5	210	4840
124	2400,00	0,02	0,4	210	4840
120	3000,00	0,02	0,3	210	4840
82	4000,00	0,01	0,2	210	4840
79	5000,00	0,01	0,2	210	4840

## NRV-P030/063

$Mn_2$ [Nm]	$i$	$Pn_1$ [kW]	$n_2$ [rpm]	$Fr_1$ [N]	$Fr_2$ [N]
166	100,00	0,24	9,0	197	4967
233	150,00	0,24	6,0	197	5686
253	200,00	0,21	4,5	197	6259
231	250,00	0,16	3,6	197	6270
255	300,00	0,17	3,0	175	6270
255	400,00	0,13	2,3	197	6270
236	500,00	0,11	1,8	197	6270
271	600,00	0,10	1,5	210	6270
271	750,00	0,09	1,2	210	6270
271	900,00	0,08	1,0	210	6270
271	1200,00	0,06	0,8	210	6270
271	1500,00	0,05	0,6	210	6270
271	1800,00	0,05	0,5	210	6270
255	2400,00	0,04	0,4	210	6270
236	3000,00	0,03	0,3	210	6270
236	4000,00	0,03	0,2	210	6270
150	5000,00	0,01	0,2	210	6270

## NRV040/050

$Mn_2$ [Nm]	$i$	$Pn_1$ [kW]	$n_2$ [rpm]	$Fr_1$ [N]	$Fr_2$ [N]
137	100,00	0,20	9,0	350	3800
135	150,00	0,14	6,0	350	4350
120	200,00	0,10	4,5	350	4788
110	250,00	0,08	3,6	350	4840
145	300,00	0,09	3,0	350	4840
124	400,00	0,07	2,3	350	4840
137	500,00	0,06	1,8	350	3800
145	600,00	0,05	1,5	350	4840
145	750,00	0,04	1,2	350	4840
135	900,00	0,04	1,0	350	4350
145	1200,00	0,03	0,8	350	4840
145	1500,00	0,03	0,6	350	4840
145	1800,00	0,02	0,5	350	4840
124	2400,00	0,02	0,4	350	4840
120	3000,00	0,01	0,3	350	4840
120	4000,00	0,01	0,2	350	4840
120	5000,00	0,01	0,2	350	4840

## NRV-P040/063

$Mn_2$ [Nm]	i	$Pn_1$ [kW]	n2 [rpm]	Fr1 [N]	Fr2 [N]
257	100,00	0,37	9,0	350	4967
260	150,00	0,27	6,0	350	5686
253	200,00	0,21	4,5	350	6259
231	250,00	0,16	3,6	350	6270
271	300,00	0,17	3,0	350	6270
255	400,00	0,13	2,3	350	6270
231	500,00	0,09	1,8	350	6270
271	600,00	0,09	1,5	350	6270
271	750,00	0,08	1,2	350	6270
271	900,00	0,07	1,0	350	6270
271	1200,00	0,06	0,8	350	6270
271	1500,00	0,05	0,6	350	6270
271	1800,00	0,04	0,5	350	6270
255	2400,00	0,03	0,4	350	6270
236	3000,00	0,03	0,3	350	6270
236	4000,00	0,02	0,2	350	6270
236	5000,00	0,02	0,2	350	6270

## NRV-P040/075

$Mn_2$ [Nm]	i	$Pn_1$ [kW]	n2 [rpm]	Fr1 [N]	Fr2 [N]
384	100,00	0,55	9,0	350	5863
425	150,00	0,42	6,0	350	6712
420	200,00	0,33	4,5	350	7380
380	250,00	0,25	3,6	350	7380
444	300,00	0,26	3,0	350	7380
414	400,00	0,20	2,3	350	7380
368	500,00	0,15	1,8	350	7380
444	600,00	0,14	1,5	350	7380
444	750,00	0,12	1,2	350	7380
444	900,00	0,11	1,0	350	7380
444	1200,00	0,09	0,8	350	7380
444	1500,00	0,08	0,6	350	7380
444	1800,00	0,07	0,5	350	7380
414	2400,00	0,05	0,4	350	7380
368	3000,00	0,04	0,3	350	7380
368	4000,00	0,03	0,2	350	7380
368	5000,00	0,03	0,2	350	7380

## NRV-P040/090

$Mn_2$ [Nm]	$i$	$Pn_1$ [kW]	$n_2$ [rpm]	$Fr_1$ [N]	$Fr_2$ [N]
394	100,00	0,55	9,0	350	6487
562	150,00	0,55	6,0	350	7426
610	200,00	0,46	4,5	350	8174
570	250,00	0,36	3,6	350	8180
700	300,00	0,40	3,0	350	8180
610	400,00	0,28	2,3	350	8180
560	500,00	0,22	1,8	350	8180
700	600,00	0,22	1,5	350	8180
700	750,00	0,18	1,2	350	8180
700	900,00	0,16	1,0	350	8180
700	1200,00	0,13	0,8	350	8180
700	1500,00	0,11	0,6	350	8180
700	1800,00	0,10	0,5	350	8180
610	2400,00	0,07	0,4	350	8180
560	3000,00	0,06	0,3	350	8180
560	4000,00	0,05	0,2	350	8180
560	5000,00	0,04	0,2	350	8180

## NRV-P050/090

$Mn_2$ [Nm]	$i$	$Pn_1$ [kW]	$n_2$ [rpm]	$Fr_1$ [N]	$Fr_2$ [N]
590	100,00	0,80	9,0	490	6487
660	150,00	0,63	6,0	490	7426
610	200,00	0,45	4,5	490	8174
570	250,00	0,35	3,6	490	8180
700	300,00	0,39	3,0	490	8180
610	400,00	0,27	2,3	490	8180
570	500,00	0,19	1,8	490	8180
700	600,00	0,21	1,5	490	8180
700	750,00	0,18	1,2	490	8180
700	900,00	0,16	1,0	490	8180
700	1200,00	0,13	0,8	490	8180
700	1500,00	0,11	0,6	490	8180
700	1800,00	0,10	0,5	490	8180
610	2400,00	0,07	0,4	490	8180
560	3000,00	0,05	0,3	490	8180
560	4000,00	0,04	0,2	490	8180
560	5000,00	0,04	0,2	490	8180

## NRV-P050/110

$Mn_2$ [Nm]	i	$Pn_1$ [kW]	n2 [rpm]	Fr1 [N]	Fr2 [N]
754	100,00	1,02	9,0	490	8198
1090	150,00	1,02	6,0	490	9384
1139	200,00	0,82	4,5	490	10320
1173	250,00	0,69	3,6	490	10320
1265	300,00	0,70	3,0	490	10320
1185	400,00	0,51	2,3	490	10320
1173	500,00	0,38	1,8	490	10320
1265	600,00	0,39	1,5	490	10320
1265	750,00	0,32	1,2	490	10320
1265	900,00	0,29	1,0	490	10320
1265	1200,00	0,23	0,8	490	10320
1265	1500,00	0,20	0,6	490	10320
1265	1800,00	0,18	0,5	490	10320
1185	2400,00	0,13	0,4	490	10320
1100	3000,00	0,10	0,3	490	10320
1100	4000,00	0,08	0,2	490	10320
1100	5000,00	0,07	0,2	490	10320

## NRV-P063/110

$Mn_2$ [Nm]	i	$Pn_1$ [kW]	n2 [rpm]	Fr1 [N]	Fr2 [N]
1127	100,00	1,52	9,0	661	8198
1196	150,00	1,12	6,0	661	9384
1139	200,00	0,82	4,5	661	10320
1173	250,00	0,69	3,6	661	10320
1265	300,00	0,70	3,0	661	10320
1185	400,00	0,51	2,3	661	10320
1173	500,00	0,38	1,8	700	10320
1265	600,00	0,38	1,5	700	10320
1265	750,00	0,31	1,2	700	10320
1265	900,00	0,28	1,0	700	10320
1265	1200,00	0,22	0,8	700	10320
1265	1500,00	0,19	0,6	700	10320
1265	1800,00	0,17	0,5	700	10320
1185	2400,00	0,12	0,4	700	10320
1100	3000,00	0,09	0,3	700	10320
1100	4000,00	0,08	0,2	700	10320
1100	5000,00	0,07	0,2	700	10320



## NRV-P063/130

Mn <sub>2</sub> [Nm]	i	Pn <sub>1</sub> [kW]	n <sub>2</sub> [rpm]	Fr1 [N]	Fr2 [N]
1270	100,00	1,70	9,0	661	10722
1700	150,00	1,61	6,0	661	12274
1600	200,00	1,15	4,5	661	13500
1530	250,00	0,90	3,6	661	13500
1760	300,00	0,96	3,0	661	13500
1650	400,00	0,70	2,3	661	13500
1550	500,00	0,55	1,8	661	13500
1760	600,00	0,52	1,5	700	13500
1760	750,00	0,43	1,2	700	13500
1760	900,00	0,38	1,0	700	13500
1760	1200,00	0,31	0,8	700	13500
1760	1500,00	0,26	0,6	700	13500
1760	1800,00	0,23	0,5	700	13500
1650	2400,00	0,17	0,4	700	13500
1550	3000,00	0,13	0,3	700	13500
1550	4000,00	0,11	0,2	700	13500
1550	5000,00	0,10	0,2	700	13500

## NRV-P063/150

Mn <sub>2</sub> [Nm]	i	Pn <sub>1</sub> [kW]	n <sub>2</sub> [rpm]	Fr1 [N]	Fr2 [N]
2325	150,00	2,16	6,0	580	18000
2340	200,00	1,68	4,5	661	18000
2050	250,00	1,21	3,6	661	18000
2340	300,00	1,16	3,0	700	18000
2670	400,00	1,12	2,3	661	18000
2330	500,00	0,83	1,8	661	18000
2670	600,00	0,77	1,5	700	18000
2330	750,00	0,58	1,2	700	18000
2100	900,00	0,42	1,0	700	18000
2670	1200,00	0,45	0,8	700	18000
2330	1500,00	0,33	0,6	700	18000
2100	1800,00	0,26	0,5	700	18000
2670	2400,00	0,27	0,4	700	18000
2330	3000,00	0,20	0,3	700	18000
2330	4000,00	0,17	0,2	700	18000
2330	5000,00	0,15	0,2	700	18000

## NRV030

$Mn_2$ [Nm]	$i$	$Pn_1$ [kW]	$n_2$ [rpm]	$Fr_1$ [N]	$Fr_2$ [N]
25	5,00	0,31	100,0	210	841
25	7,50	0,22	67,0	210	963
25	10,00	0,17	50,0	210	1060
25	15,00	0,12	33,0	210	1213
23	20,00	0,09	25,0	210	1336
30	25,00	0,10	20,0	210	1439
27	30,00	0,08	17,0	210	1529
24	40,00	0,06	13,0	210	1683
22	50,00	0,05	10,0	210	1813
19	60,00	0,04	8,0	210	1830
17	80,00	0,03	6,0	210	1830

## NRV040

$Mn_2$ [Nm]	$i$	$Pn_1$ [kW]	$n_2$ [rpm]	$Fr_1$ [N]	$Fr_2$ [N]
52	5,00	0,63	100,0	350	1619
56	7,50	0,47	67,0	350	1853
59	10,00	0,38	50,0	350	2040
61	15,00	0,28	33,0	350	2335
57	20,00	0,20	25,0	350	2570
51	25,00	0,15	20,0	350	2769
62	30,00	0,17	17,0	350	2942
58	40,00	0,13	13,0	350	3238
53	50,00	0,10	10,0	350	3488
48	60,00	0,08	8,0	350	3490
40	80,00	0,06	6,0	350	3490
36	100,00	0,05	5,0	350	3490

## NRV050

$Mn_2$ [Nm]	$i$	$Pn_1$ [kW]	$n_2$ [rpm]	$Fr_1$ [N]	$Fr_2$ [N]
101	5,00	1,23	100,0	490	2222
112	7,50	0,93	67,0	490	2544
113	10,00	0,72	50,0	490	2800
113	15,00	0,51	33,0	490	3205
100	20,00	0,35	25,0	490	3528
92	25,00	0,28	20,0	490	3800
113	30,00	0,30	17,0	490	4038
105	40,00	0,23	13,0	490	4445
96	50,00	0,18	10,0	490	4788
87	60,00	0,15	8,0	490	4840

## NRV050

$Mn_2$ [Nm]	i	$Pn_1$ [kW]	n2 [rpm]	Fr1 [N]	Fr2 [N]
75	80,00	0,11	6,0	490	4840
65	100,00	0,08	5,0	490	4840

## NRV-P063

$Mn_2$ [Nm]	i	$Pn_1$ [kW]	n2 [rpm]	Fr1 [N]	Fr2 [N]
184	7,50	1,49	67,0	700	3325
185	10,00	1,18	50,0	700	3660
200	15,00	0,90	33,0	700	4190
194	20,00	0,68	25,0	700	4611
178	25,00	0,52	20,0	700	4967
213	30,00	0,56	17,0	700	5279
206	40,00	0,44	13,0	700	5810
195	50,00	0,36	10,0	700	6259
180	60,00	0,29	8,0	700	6270
151	80,00	0,21	6,0	700	6270
128	100,00	0,16	5,0	700	6270

## NRV-P075

$Mn_2$ [Nm]	i	$Pn_1$ [kW]	n2 [rpm]	Fr1 [N]	Fr2 [N]
260	7,50	2,14	67,0	980	3925
270	10,00	1,70	50,0	980	4320
318	15,00	1,39	33,0	980	4945
326	20,00	1,11	25,0	980	5443
293	25,00	0,83	20,0	980	5863
344	30,00	0,87	17,0	980	6231
337	40,00	0,69	13,0	980	6858
314	50,00	0,55	10,0	980	7380
301	60,00	0,46	8,0	980	7380
247	80,00	0,32	6,0	980	7380
210	100,00	0,24	5,0	980	7380

## NRV-P090

$Mn_2$ [Nm]	i	$Pn_1$ [kW]	n2 [rpm]	Fr1 [N]	Fr2 [N]
451	7,50	3,66	67,0	1270	4343
479	10,00	2,95	50,0	1270	4780
539	15,00	2,29	33,0	1270	5472
517	20,00	1,71	25,0	1270	6022

## NRV-P090

Mn <sub>2</sub> [Nm]	i	Pn <sub>1</sub> [kW]	n <sub>2</sub> [rpm]	Fr1 [N]	Fr2 [N]
484	25,00	1,33	20,0	1270	6487
579	30,00	1,40	17,0	1270	6894
528	40,00	1,03	13,0	1270	7588
495	50,00	0,81	10,0	1270	8174
440	60,00	0,64	8,0	1270	8180
365	80,00	0,44	6,0	1270	8180
330	100,00	0,35	5,0	1270	8180

## NRV-P110

Mn <sub>2</sub> [Nm]	i	Pn <sub>1</sub> [kW]	n <sub>2</sub> [rpm]	Fr1 [N]	Fr2 [N]
794	7,50	6,37	67,0	1700	5488
851	10,00	5,24	50,0	1700	6040
909	15,00	3,82	33,0	1700	6914
863	20,00	2,79	25,0	1700	7610
909	25,00	2,41	20,0	1700	8198
1000	30,00	2,39	17,0	1700	8711
932	40,00	1,72	13,0	1700	9588
880	50,00	1,38	10,0	1700	10320
781	60,00	1,06	8,0	1700	10320
662	80,00	0,75	6,0	1700	10320
599	100,00	0,58	5,0	1700	10320

## NRV130

Mn <sub>2</sub> [Nm]	i	Pn <sub>1</sub> [kW]	n <sub>2</sub> [rpm]	Fr1 [N]	Fr2 [N]
1080	7,50	8,57	67,0	2100	7178
1160	10,00	7,06	50,0	2100	7900
1300	15,00	5,47	33,0	2100	9043
1230	20,00	3,93	25,0	2100	9953
1200	25,00	3,18	20,0	2100	10722
1400	30,00	3,30	17,0	2100	11394
1300	40,00	2,40	13,0	2100	12540
1220	50,00	1,88	10,0	2100	13500
1070	60,00	1,46	8,0	2100	13500
970	80,00	1,08	6,0	2100	13500
860	100,00	0,83	5,0	2100	13500

## NRV150

$Mn_2$ [Nm]	$i$	$Pn_1$ [kW]	$n_2$ [rpm]	$Fr_1$ [N]	$Fr_2$ [N]
1700	7,50	13,49	67,0	2800	9812
1780	10,00	10,71	50,0	2800	10800
1730	15,00	7,19	33,0	2800	12363
1820	20,00	5,81	25,0	2800	13607
1630	25,00	4,27	20,0	2800	14658
1670	30,00	3,74	17,0	2800	15576
2120	40,00	3,38	13,0	2800	17144
1870	50,00	2,84	10,0	2800	18000
1680	60,00	2,26	8,0	2800	18000
1530	80,00	1,67	6,0	2800	18000
1350	100,00	1,29	5,0	2800	18000

## NRV030/040

Mn <sub>2</sub> [Nm]	i	Pn <sub>1</sub> [kW]	n <sub>2</sub> [rpm]	Fr1 [N]	Fr2 [N]
71	100,00	0,06	5,0	210	2769
72	150,00	0,04	3,3	210	3169
65	200,00	0,03	2,5	210	3488
61	250,00	0,03	2,0	210	3490
73	300,00	0,03	1,7	210	3490
65	400,00	0,02	1,3	210	3490
61	500,00	0,01	1,0	210	3490
73	600,00	0,02	0,8	210	3490
73	750,00	0,01	0,7	210	3490
73	900,00	0,01	0,6	210	3490
73	1200,00	0,01	0,4	210	3490
73	1500,00	0,01	0,3	210	3490
73	1800,00	0,01	0,3	210	3490
65	2400,00	0,01	0,2	210	3490
60	3000,00	0,01	0,2	210	3490
48	4000,00	0,00	0,1	210	3490
43	5000,00	0,00	0,1	210	3490

## NRV030/050

Mn <sub>2</sub> [Nm]	i	Pn <sub>1</sub> [kW]	n <sub>2</sub> [rpm]	Fr1 [N]	Fr2 [N]
137	100,00	0,12	5,0	210	3800
135	150,00	0,08	3,3	210	4350
120	200,00	0,06	2,5	210	4788
110	250,00	0,04	2,0	210	4840
145	300,00	0,05	1,7	210	4840
124	400,00	0,04	1,3	210	4840
120	500,00	0,03	1,0	210	4840
145	600,00	0,03	0,8	210	4840
145	750,00	0,03	0,7	210	4840
145	900,00	0,02	0,6	210	4840
145	1200,00	0,02	0,4	210	4840
145	1500,00	0,02	0,3	210	4840
145	1800,00	0,02	0,3	210	4840
124	2400,00	0,01	0,2	210	4840
120	3000,00	0,01	0,2	210	4840
82	4000,00	0,01	0,1	210	4840
79	5000,00	0,01	0,1	210	4840

## NRV-P030/063

$Mn_2$ [Nm]	$i$	$Pn_1$ [kW]	$n_2$ [rpm]	$Fr_1$ [N]	$Fr_2$ [N]
198	100,00	0,17	5,0	210	4967
260	150,00	0,16	3,3	210	5686
253	200,00	0,12	2,5	210	6259
231	250,00	0,09	2,0	210	6270
255	300,00	0,10	1,7	210	6270
255	400,00	0,08	1,3	210	6270
236	500,00	0,06	1,0	210	6270
271	600,00	0,06	0,8	210	6270
271	750,00	0,05	0,7	210	6270
271	900,00	0,04	0,6	210	6270
271	1200,00	0,04	0,4	210	6270
271	1500,00	0,03	0,3	210	6270
271	1800,00	0,03	0,3	210	6270
255	2400,00	0,02	0,2	210	6270
236	3000,00	0,02	0,2	210	6270
236	4000,00	0,02	0,1	210	6270
150	5000,00	0,01	0,1	210	6270

## NRV040/050

$Mn_2$ [Nm]	$i$	$Pn_1$ [kW]	$n_2$ [rpm]	$Fr_1$ [N]	$Fr_2$ [N]
137	100,00	0,11	5,0	350	3800
135	150,00	0,08	3,3	350	4350
120	200,00	0,06	2,5	350	4788
110	250,00	0,04	2,0	350	4840
145	300,00	0,05	1,7	350	4840
124	400,00	0,04	1,3	350	4840
137	500,00	0,03	1,0	350	3800
145	600,00	0,03	0,8	350	4840
145	750,00	0,02	0,7	350	4840
135	900,00	0,02	0,6	350	4350
145	1200,00	0,02	0,4	350	4840
145	1500,00	0,01	0,3	350	4840
145	1800,00	0,01	0,3	350	4840
124	2400,00	0,01	0,2	350	4840
120	3000,00	0,01	0,2	350	4840
120	4000,00	0,01	0,1	350	4840
120	5000,00	0,01	0,1	350	4840

## NRV-P040/063

$Mn_2$ [Nm]	i	$Pn_1$ [kW]	n2 [rpm]	Fr1 [N]	Fr2 [N]
257	100,00	0,21	5,0	350	4967
260	150,00	0,15	3,3	350	5686
253	200,00	0,12	2,5	350	6259
231	250,00	0,09	2,0	350	6270
271	300,00	0,10	1,7	350	6270
255	400,00	0,07	1,3	350	6270
231	500,00	0,05	1,0	350	6270
271	600,00	0,05	0,8	350	6270
271	750,00	0,04	0,7	350	6270
271	900,00	0,04	0,6	350	6270
271	1200,00	0,03	0,4	350	6270
271	1500,00	0,03	0,3	350	6270
271	1800,00	0,03	0,3	350	6270
255	2400,00	0,02	0,2	350	6270
236	3000,00	0,02	0,2	350	6270
236	4000,00	0,01	0,1	350	6270
236	5000,00	0,01	0,1	350	6270

## NRV-P040/075

$Mn_2$ [Nm]	i	$Pn_1$ [kW]	n2 [rpm]	Fr1 [N]	Fr2 [N]
405	100,00	0,33	5,0	350	5863
425	150,00	0,24	3,3	350	6712
420	200,00	0,19	2,5	350	7380
380	250,00	0,14	2,0	350	7380
444	300,00	0,15	1,7	350	7380
414	400,00	0,11	1,3	350	7380
368	500,00	0,09	1,0	350	7380
444	600,00	0,08	0,8	350	7380
444	750,00	0,07	0,7	350	7380
444	900,00	0,06	0,6	350	7380
444	1200,00	0,05	0,4	350	7380
444	1500,00	0,04	0,3	350	7380
444	1800,00	0,04	0,3	350	7380
414	2400,00	0,03	0,2	350	7380
368	3000,00	0,02	0,2	350	7380
368	4000,00	0,02	0,1	350	7380
368	5000,00	0,02	0,1	350	7380



## NRV-P040/090

$Mn_2$ [Nm]	$i$	$Pn_1$ [kW]	$n_2$ [rpm]	$Fr_1$ [N]	$Fr_2$ [N]
484	100,00	0,38	5,0	350	6487
660	150,00	0,36	3,3	350	7426
610	200,00	0,26	2,5	350	8174
570	250,00	0,20	2,0	350	8180
700	300,00	0,23	1,7	350	8180
610	400,00	0,16	1,3	350	8180
560	500,00	0,12	1,0	350	8180
700	600,00	0,12	0,8	350	8180
700	750,00	0,10	0,7	350	8180
700	900,00	0,09	0,6	350	8180
700	1200,00	0,08	0,4	350	8180
700	1500,00	0,07	0,3	350	8180
700	1800,00	0,06	0,3	350	8180
610	2400,00	0,04	0,2	350	8180
560	3000,00	0,03	0,2	350	8180
560	4000,00	0,03	0,1	350	8180
560	5000,00	0,03	0,1	350	8180

## NRV-P050/090

$Mn_2$ [Nm]	$i$	$Pn_1$ [kW]	$n_2$ [rpm]	$Fr_1$ [N]	$Fr_2$ [N]
590	100,00	0,46	5,0	490	6487
660	150,00	0,36	3,3	490	7426
610	200,00	0,26	2,5	490	8174
570	250,00	0,20	2,0	490	8180
700	300,00	0,22	1,7	490	8180
610	400,00	0,16	1,3	490	8180
570	500,00	0,11	1,0	490	8180
700	600,00	0,12	0,8	490	8180
700	750,00	0,10	0,7	490	8180
700	900,00	0,09	0,6	490	8180
700	1200,00	0,08	0,4	490	8180
700	1500,00	0,07	0,3	490	8180
700	1800,00	0,06	0,3	490	8180
610	2400,00	0,04	0,2	490	8180
560	3000,00	0,03	0,2	490	8180
560	4000,00	0,03	0,1	490	8180
560	5000,00	0,03	0,1	490	8180

## NRV-P050/110

$Mn_2$ [Nm]	$i$	$Pn_1$ [kW]	$n_2$ [rpm]	$Fr_1$ [N]	$Fr_2$ [N]
927	100,00	0,72	5,0	490	8198
1196	150,00	0,64	3,3	490	9384
1139	200,00	0,47	2,5	490	10320
1173	250,00	0,40	2,0	490	10320
1265	300,00	0,40	1,7	490	10320
1185	400,00	0,29	1,3	490	10320
1173	500,00	0,22	1,0	490	10320
1265	600,00	0,22	0,8	490	10320
1265	750,00	0,19	0,7	490	10320
1265	900,00	0,17	0,6	490	10320
1265	1200,00	0,14	0,4	490	10320
1265	1500,00	0,12	0,3	490	10320
1265	1800,00	0,11	0,3	490	10320
1185	2400,00	0,08	0,2	490	10320
1100	3000,00	0,06	0,2	490	10320
1100	4000,00	0,05	0,1	490	10320
1100	5000,00	0,04	0,1	490	10320

## NRV-P063/110

$Mn_2$ [Nm]	$i$	$Pn_1$ [kW]	$n_2$ [rpm]	$Fr_1$ [N]	$Fr_2$ [N]
1127	100,00	0,88	5,0	700	8198
1196	150,00	0,64	3,3	700	9384
1139	200,00	0,47	2,5	700	10320
1173	250,00	0,40	2,0	700	10320
1265	300,00	0,40	1,7	700	10320
1185	400,00	0,29	1,3	700	10320
1173	500,00	0,22	1,0	700	10320
1265	600,00	0,22	0,8	700	10320
1265	750,00	0,18	0,7	700	10320
1265	900,00	0,17	0,6	700	10320
1265	1200,00	0,13	0,4	700	10320
1265	1500,00	0,12	0,3	700	10320
1265	1800,00	0,10	0,3	700	10320
1185	2400,00	0,07	0,2	700	10320
1100	3000,00	0,06	0,2	700	10320
1100	4000,00	0,05	0,1	700	10320
1100	5000,00	0,04	0,1	700	10320

## NRV-P063/130

$Mn_2$ [Nm]	$i$	$Pn_1$ [kW]	$n_2$ [rpm]	$Fr_1$ [N]	$Fr_2$ [N]
1530	100,00	1,18	5,0	700	10722
1700	150,00	0,93	3,3	700	12274
1600	200,00	0,66	2,5	700	13500
1530	250,00	0,52	2,0	700	13500
1760	300,00	0,55	1,7	700	13500
1650	400,00	0,41	1,3	700	13500
1550	500,00	0,32	1,0	700	13500
1760	600,00	0,30	0,8	700	13500
1760	750,00	0,25	0,7	700	13500
1760	900,00	0,23	0,6	700	13500
1760	1200,00	0,18	0,4	700	13500
1760	1500,00	0,16	0,3	700	13500
1760	1800,00	0,14	0,3	700	13500
1650	2400,00	0,10	0,2	700	13500
1550	3000,00	0,08	0,2	700	13500
1550	4000,00	0,07	0,1	700	13500
1550	5000,00	0,06	0,1	700	13500

## NRV-P063/150

$Mn_2$ [Nm]	$i$	$Pn_1$ [kW]	$n_2$ [rpm]	$Fr_1$ [N]	$Fr_2$ [N]
2340	150,00	1,23	3,3	700	18000
2340	200,00	0,97	2,5	700	18000
2050	250,00	0,70	2,0	700	18000
2340	300,00	0,68	1,7	700	18000
2670	400,00	0,65	1,3	700	18000
2330	500,00	0,48	1,0	700	18000
2670	600,00	0,45	0,8	700	18000
2330	750,00	0,34	0,7	700	18000
2100	900,00	0,25	0,6	700	18000
2670	1200,00	0,27	0,4	700	18000
2330	1500,00	0,20	0,3	700	18000
2100	1800,00	0,15	0,3	700	18000
2670	2400,00	0,16	0,2	700	18000
2330	3000,00	0,12	0,2	700	18000
2330	4000,00	0,10	0,1	700	18000
2330	5000,00	0,09	0,1	700	18000

## IHW040+NMRV-P090

Mn <sub>2</sub> [Nm]	i	Pn <sub>1</sub> [kW]	n <sub>2</sub> [rpm]	Fr1 [N]	Fr2 [N]
415	23,29	3,90	75,1	300	4343
460	31,05	3,27	56,4	400	4780
494	42,00	2,64	41,7	400	4780
518	46,58	2,54	37,6	400	5472
573	63,00	2,12	27,8	400	5472
444	77,63	1,41	22,5	400	6487
549	84,00	1,59	20,8	400	6022
556	93,16	1,54	18,8	400	6894
601	110,00	1,35	15,9	400	6022
615	126,00	1,31	13,9	400	6894
591	137,50	1,10	12,7	400	6487
468	155,26	0,87	11,3	400	8174
673	165,00	1,12	10,6	400	6894
418	186,32	0,69	9,4	400	8180
614	220,00	0,82	8,0	400	7588
469	252,00	0,60	6,9	400	8180
573	275,00	0,65	6,4	400	8174
587	304,55	0,61	5,8	400	8180
503	330,00	0,51	5,3	400	8180
612	383,33	0,51	4,6	400	8180
624	437,50	0,46	4,0	400	8180
534	460,00	0,40	3,8	400	8180
544	525,00	0,36	3,3	400	8180
426	613,33	0,27	2,9	400	8180
432	700,00	0,24	2,5	400	8180
351	766,67	0,19	2,3	400	8180
354	875,00	0,17	2,0	400	8180

## IHW040+NMRV-P110

Mn <sub>2</sub> [Nm]	i	Pn <sub>1</sub> [kW]	n <sub>2</sub> [rpm]	Fr1 [N]	Fr2 [N]
421	23,29	3,90	75,1	300	5488
548	31,05	3,89	56,4	300	6040
494	42,00	2,64	41,7	500	6040
805	46,58	3,89	37,6	300	6914
783	62,11	2,91	28,2	500	7610
829	77,63	2,53	22,5	500	8198
938	84,00	2,64	20,8	500	7610
917	93,16	2,50	18,8	500	8711
1014	105,00	2,34	16,7	500	8198
1109	126,00	2,33	13,9	500	8711
938	137,50	1,68	12,7	500	8198

## IHW040+NMRV-P110

$Mn_2$ [Nm]	$i$	$Pn_1$ [kW]	$n_2$ [rpm]	$Fr_1$ [N]	$Fr_2$ [N]
828	155,26	1,48	11,3	500	10320
1016	168,00	1,65	10,4	500	9588
739	186,32	1,15	9,4	500	10320
1115	220,00	1,42	8,0	500	9588
836	252,00	1,01	6,9	500	10320
1029	275,00	1,11	6,4	500	10320
1055	304,55	1,03	5,8	500	10320
900	330,00	0,85	5,3	500	10320
937	383,33	0,74	4,6	500	10320
750	440,00	0,59	4,0	500	10320
959	460,00	0,67	3,8	500	10320
905	525,00	0,56	3,3	500	10320
793	613,33	0,46	2,9	500	10320
807	700,00	0,41	2,5	500	10320
638	766,67	0,32	2,3	500	10320
642	875,00	0,29	2,0	500	10320

## IHW040+NMRV-P090

Mn <sub>2</sub> [Nm]	i	Pn <sub>1</sub> [kW]	n <sub>2</sub> [rpm]	Fr1 [N]	Fr2 [N]
411	23,29	3,11	60,1	300	4343
496	31,05	2,86	45,1	400	4780
492	42,00	2,12	33,3	400	4780
558	46,58	2,23	30,1	400	5472
617	63,00	1,86	22,2	400	5472
513	77,63	1,33	18,0	400	6487
592	84,00	1,39	16,7	400	6022
599	93,16	1,37	15,0	400	6894
647	110,00	1,17	12,7	400	8174
663	126,00	1,15	11,1	400	6894
637	137,50	0,96	10,2	400	8180
514	155,26	0,79	9,0	400	8174
725	165,00	0,98	8,5	400	8180
457	186,32	0,63	7,5	400	8180
661	220,00	0,72	6,4	400	8180
496	252,00	0,52	5,6	400	8180
599	275,00	0,56	5,1	400	8180
552	304,55	0,47	4,6	400	8180
524	330,00	0,44	4,2	400	8180
632	383,33	0,43	3,6	400	8180
642	437,50	0,39	3,2	400	8180
550	460,00	0,34	3,0	400	8180
558	525,00	0,30	2,7	400	8180
435	613,33	0,22	2,3	400	8180
439	700,00	0,20	2,0	400	8180
356	766,67	0,16	1,8	400	8180
359	875,00	0,14	1,6	400	8180

## IHW040+NMRV-P110

Mn <sub>2</sub> [Nm]	i	Pn <sub>1</sub> [kW]	n <sub>2</sub> [rpm]	Fr1 [N]	Fr2 [N]
415	23,29	3,11	60,1	300	5488
541	31,05	3,12	45,1	300	6040
492	42,00	2,12	33,3	500	6040
791	46,58	3,12	30,1	300	6914
904	62,11	2,74	22,5	500	7610
968	77,63	2,41	18,0	500	8198
930	84,00	2,12	16,7	500	7610
1035	93,16	2,33	15,0	500	8711
1112	105,00	2,08	13,3	500	8198
1189	126,00	2,05	11,1	500	8711
947	137,50	1,37	10,2	500	10320

## IHW040+NMRV-P110

$Mn_2$ [Nm]	$i$	$Pn_1$ [kW]	$n_2$ [rpm]	$Fr_1$ [N]	$Fr_2$ [N]
920	155,26	1,35	9,0	500	10320
1095	168,00	1,46	8,3	500	9588
813	186,32	1,05	7,5	500	10320
1175	220,00	1,22	6,4	500	10320
888	252,00	0,88	5,6	500	10320
1079	275,00	0,94	5,1	500	10320
978	304,55	0,78	4,6	500	10320
941	330,00	0,73	4,2	500	10320
957	383,33	0,61	3,6	500	10320
780	440,00	0,50	3,2	500	10320
990	460,00	0,56	3,0	500	10320
927	525,00	0,47	2,7	500	10320
816	613,33	0,38	2,3	500	10320
827	700,00	0,34	2,0	500	10320
646	766,67	0,27	1,8	500	10320
652	875,00	0,24	1,6	500	10320

## IHW040+NMRV-P090

Mn <sub>2</sub> [Nm]	i	Pn <sub>1</sub> [kW]	n <sub>2</sub> [rpm]	Fr1 [N]	Fr2 [N]
409	23,29	2,54	49,0	300	4343
531	31,05	2,52	36,7	400	4780
496	42,00	1,76	27,1	400	6487
597	46,58	1,97	24,5	400	5472
661	63,00	1,64	18,1	400	7426
564	77,63	1,20	14,7	400	6487
634	84,00	1,22	13,6	400	8174
642	93,16	1,22	12,2	400	6894
693	110,00	1,03	10,4	400	8174
710	126,00	1,02	9,1	400	8180
669	137,50	0,83	8,3	400	8180
551	155,26	0,71	7,3	400	8174
776	165,00	0,86	6,9	400	8180
486	186,32	0,56	6,1	400	8180
708	220,00	0,64	5,2	400	8180
519	252,00	0,46	4,5	400	8180
621	275,00	0,48	4,2	400	8180
630	304,55	0,44	3,7	400	8180
541	330,00	0,37	3,5	400	8180
647	383,33	0,36	3,0	400	8180
655	437,50	0,33	2,6	400	8180
562	460,00	0,28	2,5	400	8180
568	525,00	0,25	2,2	400	8180
450	613,33	0,19	1,9	400	8180
456	700,00	0,17	1,6	400	8180
362	766,67	0,14	1,5	400	8180
365	875,00	0,12	1,3	400	8180

## IHW040+NMRV-P110

Mn <sub>2</sub> [Nm]	i	Pn <sub>1</sub> [kW]	n <sub>2</sub> [rpm]	Fr1 [N]	Fr2 [N]
411	23,29	2,54	49,0	300	5488
535	31,05	2,53	36,7	300	6040
496	42,00	1,76	27,1	500	8198
780	46,58	2,54	24,5	300	6914
1014	62,11	2,54	18,4	500	7610
1077	77,63	2,21	14,7	500	8198
935	84,00	1,76	13,6	500	10320
1173	93,16	2,20	12,2	500	8711
1139	105,00	1,76	10,9	500	10320
1232	126,00	1,76	9,1	500	10320
957	137,50	1,14	8,3	500	10320



## IHW040+NMRV-P110

$Mn_2$ [Nm]	$i$	$Pn_1$ [kW]	$n_2$ [rpm]	$Fr_1$ [N]	$Fr_2$ [N]
989	155,26	1,21	7,3	500	10320
1193	168,00	1,32	6,8	500	10320
868	186,32	0,93	6,1	500	10320
1259	220,00	1,08	5,2	500	10320
983	252,00	0,81	4,5	500	10320
1170	275,00	0,84	4,2	500	10320
1152	304,55	0,75	3,7	500	10320
1028	330,00	0,66	3,5	500	10320
948	383,33	0,50	3,0	500	10320
860	440,00	0,45	2,6	500	10320
1060	460,00	0,50	2,5	500	10320
917	525,00	0,38	2,2	500	10320
891	613,33	0,34	1,9	500	10320
901	700,00	0,31	1,6	500	10320
747	766,67	0,26	1,5	500	10320
752	875,00	0,23	1,3	500	10320

## IHW040+NMRV-P090

Mn <sub>2</sub> [Nm]	i	Pn <sub>1</sub> [kW]	n <sub>2</sub> [rpm]	Fr1 [N]	Fr2 [N]
425	23,29	2,10	38,6	300	5894
555	31,05	2,09	29,0	400	6487
505	42,00	1,42	21,4	400	6487
646	46,58	1,70	19,3	400	7426
715	63,00	1,41	14,3	400	7426
610	77,63	1,04	11,6	400	8180
686	84,00	1,06	10,7	400	8174
694	93,16	1,06	9,7	400	8180
750	110,00	0,89	8,2	400	8174
768	126,00	0,88	7,1	400	8180
699	137,50	0,69	6,5	400	8180
584	155,26	0,61	5,8	400	8180
840	165,00	0,74	5,5	400	8180
511	186,32	0,48	4,8	400	8180
766	220,00	0,55	4,1	400	8180
538	252,00	0,38	3,6	400	8180
641	275,00	0,40	3,3	400	8180
639	304,55	0,36	3,0	400	8180
557	330,00	0,31	2,7	400	8180
662	383,33	0,30	2,4	400	8180
669	437,50	0,27	2,1	400	8180
574	460,00	0,23	2,0	400	8180
579	525,00	0,21	1,7	400	8180
461	613,33	0,15	1,5	400	8180
466	700,00	0,14	1,3	400	8180
366	766,67	0,11	1,2	400	8180
369	875,00	0,10	1,0	400	8180

## IHW040+NMRV-P110

Mn <sub>2</sub> [Nm]	i	Pn <sub>1</sub> [kW]	n <sub>2</sub> [rpm]	Fr1 [N]	Fr2 [N]
427	23,29	2,10	38,6	300	7448
555	31,05	2,09	29,0	300	8198
505	42,00	1,42	21,4	500	8198
806	46,58	2,10	19,3	300	9384
1048	62,11	2,10	14,5	500	10320
1167	77,63	1,92	11,6	500	10320
949	84,00	1,42	10,7	500	10320
1252	93,16	1,90	9,7	500	10320
1156	105,00	1,42	8,6	500	10320
1241	126,00	1,42	7,1	500	10320
969	137,50	0,92	6,5	500	10320

## IHW040+NMRV-P110

$Mn_2$ [Nm]	$i$	$Pn_1$ [kW]	$n_2$ [rpm]	$Fr_1$ [N]	$Fr_2$ [N]
1050	155,26	1,03	5,8	500	10320
1219	168,00	1,08	5,4	500	10320
917	186,32	0,80	4,8	500	10320
1272	220,00	0,87	4,1	500	10320
969	252,00	0,64	3,6	500	10320
1158	275,00	0,67	3,3	500	10320
1158	304,55	0,60	3,0	500	10320
1003	330,00	0,52	2,7	500	10320
1009	383,33	0,42	2,4	500	10320
825	440,00	0,35	2,0	500	10320
1035	460,00	0,39	2,0	500	10320
932	525,00	0,31	1,7	500	10320
848	613,33	0,26	1,5	500	10320
857	700,00	0,23	1,3	500	10320
663	766,67	0,18	1,2	500	10320
670	875,00	0,16	1,0	500	10320

## 0,09 kW

n2 [rpm]	M2 [Nm]	fs	i	Gear reducer	Size	Motor Pole	Fr2 [N]
125,0	6	3,3	10,00	SW030	56B	4	752
115,0	6	3,4	7,50	SW030	63A	6	792
86,0	8	2,6	10,00	SW030	63A	6	871
83,0	8	2,4	15,00	SW030	56B	4	861
63,0	10	1,8	20,00	SW030	56B	4	948
57,0	11	1,9	15,00	SW030	63A	6	997
50,0	12	1,9	25,00	SW030	56B	4	1021
43,0	14	1,4	20,00	SW030	63A	6	1098
43,0	15	3,2	20,00	SW040	63A	6	2113
42,0	14	1,5	30,00	SW030	56B	4	1085
34,0	16	1,5	25,00	SW030	63A	6	1183
34,0	18	2,5	25,00	SW040	63A	6	2276
31,0	17	1,2	40,00	SW030	56B	4	1194
29,0	19	1,2	30,00	SW030	63A	6	1257
29,0	20	2,6	30,00	SW040	63A	6	2419
25,0	19	0,9	50,00	SW030	56B	4	1286
25,0	22	1,9	50,00	SW040	56B	4	2475
22,0	22	0,9	40,00	SW030	63A	6	1383
22,0	25	2,0	40,00	SW040	63A	6	2662
22,0	26	3,4	40,00	SW050	63A	6	3654
21,0	21	0,7	60,00	SW030	56B	4	1367
21,0	24	1,6	60,00	SW040	56B	4	2630
17,0	26	0,7	50,00	SW030	63A	6	1490
17,0	29	1,6	50,00	SW040	63A	6	2868
17,0	30	2,7	50,00	SW050	63A	6	3936
16,0	29	1,1	80,00	SW040	56B	4	2895
14,0	33	1,2	60,00	SW040	63A	6	3047
14,0	34	2,3	60,00	SW050	63A	6	4183
13,0	33	0,9	100,00	SW040	56B	4	3118
12,5	39	1,8	100,00	SW030/040	56B	4	2769
12,5	40	3,4	100,00	SW030/050	56B	4	3800
12,5	40	3,7	100,00	SW030/063	56B	4	4967
11,0	59	3,7	81,82	HA31+SW063	63A	6	6155
11,0	39	0,9	80,00	SW040	63A	6	3354
11,0	40	1,7	80,00	SW050	63A	6	4604
9,0	64	3,9	95,00	HA31+SW063	63A	6	6270
9,0	44	0,7	100,00	SW040	63A	6	3490
9,0	45	1,2	100,00	SW050	63A	6	4840
8,3	55	1,3	150,00	SW030/040	56B	4	3169
8,3	55	2,4	150,00	SW030/050	56B	4	4350
8,3	56	2,6	150,00	SW030/063	56B	4	4967
8,0	69	3,7	102,00	HA31+SW063	63A	6	6270

## 0,09 kW

n2 [rpm]	M2 [Nm]	fs	i	Gear reducer	Size	Motor Pole	Fr2 [N]
8,0	74	3,4	109,09	HA31+SW063	63A	6	6270
8,0	76	3,7	109,09	HA31+SW075	63A	6	7380
7,0	69	3,8	116,00	HA31+SW063	63A	6	6270
7,0	83	2,8	127,50	HA31+SW063	63A	6	6270
6,2	69	0,9	200,00	SW030/040	56B	4	3488
6,2	69	1,7	200,00	SW030/050	56B	4	4788
6,2	71	2,0	200,00	SW030/063	56B	4	4967
6,0	84	3,2	142,50	HA31+SW063	63A	6	6270
5,0	92	2,8	168,57	HA31+SW063	63A	6	6270
5,0	107	2,4	157,50	HA31+SW063	63A	6	6270
5,0	102	3,7	163,64	HA31+SW075	63A	6	7380
5,0	82	0,7	250,00	SW030/040	56B	4	3490
5,0	82	1,3	250,00	SW030/050	56B	4	4840
5,0	83	2,1	250,00	SW030/063	56B	4	4967
4,9	91	3,6	176,67	HA31+SW075	63A	6	7380
4,6	112	2,4	189,00	HA31+SW063	63A	6	6270
4,4	102	3,5	193,33	HA31+SW075	63A	6	7380
4,2	111	2,3	204,00	HA31+SW063	63A	6	6270
4,2	89	0,8	300,00	SW030/040	56B	4	3490
4,2	91	1,6	300,00	SW030/050	56B	4	4840
4,2	87	2,9	300,00	SW030/063	56B	4	6270
3,9	118	2,2	218,18	HA31+SW063	63A	6	6270
3,9	125	3,3	218,18	HA31+SW075	63A	6	7380
3,9	131	3,7	218,18	HA31+SW090	63A	6	8180
3,6	140	1,9	236,25	HA31+SW063	63A	6	6270
3,6	124	3,0	237,50	HA31+SW075	63A	6	7380
3,4	143	3,9	255,00	HA31+SW090	63A	6	8180
3,2	137	1,7	272,73	HA31+SW063	63A	6	6270
3,2	143	2,6	272,73	HA31+SW075	63A	6	7380
3,2	153	3,7	272,73	HA31+SW090	63A	6	8180
3,1	109	1,1	400,00	SW030/050	56B	4	4840
3,1	113	2,2	400,00	SW030/063	56B	4	6270
2,8	160	3,2	306,00	HA31+SW090	63A	6	8180
2,7	171	1,5	315,00	HA31+SW063	63A	6	6270
2,7	180	2,3	315,00	HA31+SW075	63A	6	7380
2,6	171	2,9	327,27	HA31+SW090	63A	6	8180
2,5	126	0,9	500,00	SW030/050	56B	4	4840
2,5	131	1,8	500,00	SW030/063	56B	4	6270
2,3	181	2,5	380,00	HA31+SW090	63A	6	8180
2,2	198	1,2	393,75	HA31+SW063	63A	6	6270
2,2	206	1,8	393,75	HA31+SW075	63A	6	7380
2,1	194	2,4	408,00	HA31+SW090	63A	6	8180

## 0,09 kW

n2 [rpm]	M2 [Nm]	fs	i	Gear reducer	Size	Motor Pole	Fr2 [N]
2,1	162	0,9	600,00	SW030/050	56B	4	4840
2,1	164	1,6	600,00	SW030/063	56B	4	6270
2,0	235	1,1	433,33	HA31+SW063	63A	6	6270
2,0	207	2,2	436,36	HA31+SW090	63A	6	8180
1,8	220	1,0	472,50	HA31+SW063	63A	6	6270
1,8	234	1,5	472,50	HA31+SW075	63A	6	7380
1,8	247	2,0	472,50	HA31+SW090	63A	6	8180
1,7	218	1,9	510,00	HA31+SW090	63A	6	8180
1,7	189	0,8	750,00	SW030/050	56B	4	4840
1,7	192	1,4	750,00	SW030/063	56B	4	6270
1,6	273	0,9	541,67	HA31+SW063	63A	6	6270
1,6	284	1,1	541,67	HA31+SW075	63A	6	7380
1,6	233	1,8	545,45	HA31+SW090	63A	6	8180
1,4	299	1,5	630,00	HA31+SW090	63A	6	8180
1,4	220	1,2	900,00	SW030/063	56B	4	6270
1,3	302	0,7	650,00	HA31+SW063	63A	6	6270
1,3	321	1,1	650,00	HA31+SW075	63A	6	7380
1,3	340	1,1	650,00	HA31+SW090	63A	6	8180
1,1	305	0,8	787,50	HA31+SW075	63A	6	7380
1,1	336	1,2	787,50	HA31+SW090	63A	6	8180
1,0	267	1,0	1200,00	SW030/063	56B	4	6270
1,0	378	0,8	866,67	HA31+SW075	63A	6	7380
1,0	412	1,1	866,67	HA31+SW090	63A	6	8180
0,8	312	0,9	1500,00	SW030/063	56B	4	6270
0,8	367	1,2	1500,00	SW040/075	56B	4	7380
0,8	385	1,8	1500,00	SW040/090	56B	4	8180
0,7	347	0,8	1800,00	SW030/063	56B	4	6270
0,7	412	1,1	1800,00	SW040/075	56B	4	7380
0,7	432	1,6	1800,00	SW040/090	56B	4	8180
0,5	507	0,8	2400,00	SW040/075	56B	4	7380
0,5	533	1,1	2400,00	SW040/090	56B	4	8180
0,4	623	0,9	3000,00	SW040/090	56B	4	8180
0,3	747	0,7	4000,00	SW040/090	56B	4	8180

## 0,12 kW

n2 [rpm]	M2 [Nm]	fs	i	Gear reducer	Size	Motor Pole	Fr2 [N]
264,0	4	3,5	10,00	SW030	56B	2	597
180,3	5	3,5	7,50	SW030	63A	4	683
176,3	5	2,4	15,00	SW030	56B	2	683
174,0	6	3,7	5,00	SW030	63B	6	692
135,0	7	2,7	10,00	SW030	63A	4	752

## 0,12 kW

n2 [rpm]	M2 [Nm]	fs	i	Gear reducer	Motor		Fr2 [N]
					Size	Pole	
132,5	7	1,8	20,00	SW030	56B	2	752
116,3	8	2,5	7,50	SW030	63B	6	792
105,6	8	2,0	25,00	SW030	56B	2	810
89,7	10	1,9	15,00	SW030	63A	4	861
87,7	9	1,6	30,00	SW030	56B	2	861
87,0	11	1,9	10,00	SW030	63B	6	871
67,5	13	1,4	20,00	SW030	63A	4	948
67,5	14	3,2	20,00	SW040	63A	4	1824
65,8	12	1,2	40,00	SW030	56B	2	948
57,7	15	1,4	15,00	SW030	63B	6	997
57,7	16	3,2	15,00	SW040	63B	6	1920
54,4	15	1,5	25,00	SW030	63A	4	1021
54,4	16	2,4	25,00	SW040	63A	4	1964
52,8	14	1,0	50,00	SW030	56B	2	1021
52,8	15	2,0	50,00	SW040	56B	2	1964
45,3	17	1,2	30,00	SW030	63A	4	1085
45,3	18	2,6	30,00	SW040	63A	4	2087
43,8	15	0,8	60,00	SW030	56B	2	1085
43,8	17	1,6	60,00	SW040	56B	2	2087
43,5	19	1,1	20,00	SW030	63B	6	1098
43,5	20	2,4	20,00	SW040	63B	6	2113
34,4	22	1,1	25,00	SW030	63B	6	1183
34,4	24	1,9	25,00	SW040	63B	6	2276
34,3	21	0,9	40,00	SW030	63A	4	1194
34,3	23	2,0	40,00	SW040	63A	4	2298
34,3	23	3,5	40,00	SW050	63A	4	3153
32,9	21	1,2	80,00	SW040	56B	2	2298
29,3	25	0,9	30,00	SW030	63B	6	1257
29,3	27	2,0	30,00	SW040	63B	6	2419
27,2	24	0,8	50,00	SW030	63A	4	1286
27,2	27	1,6	50,00	SW040	63A	4	2475
27,2	27	2,8	50,00	SW050	63A	4	3397
26,9	24	1,0	100,00	SW040	56B	2	2475
22,3	40	3,6	38,67	HA31+SW063	63B	6	4795
22,3	30	0,7	40,00	SW030	63B	6	1383
22,3	34	1,5	40,00	SW040	63B	6	2662
22,3	34	2,6	40,00	SW050	63B	6	3654
22,2	30	1,3	60,00	SW040	63A	4	2630
22,2	31	2,3	60,00	SW050	63A	4	3610
18,2	48	3,1	47,50	HA31+SW063	63B	6	5135
17,2	39	1,2	50,00	SW040	63B	6	2868
17,2	40	2,0	50,00	SW050	63B	6	3936

## 0,12 kW

n2 [rpm]	M2 [Nm]	fs	i	Gear reducer	Size	Motor Pole	Fr2 [N]
17,1	36	0,9	80,00	SW040	63A	4	2895
17,1	37	1,8	80,00	SW050	63A	4	3973
16,1	51	4,0	81,82	HA31+SW063	63A	4	5309
14,2	43	0,9	60,00	SW040	63B	6	3047
14,2	44	1,7	60,00	SW050	63B	6	4183
13,5	52	1,4	100,00	SW030/040	63A	4	2769
13,5	54	2,6	100,00	SW030/050	63A	4	3800
13,5	54	2,8	100,00	SW030/063	63A	4	4967
13,1	60	4,0	102,00	HA31+SW063	63A	4	5714
13,1	41	0,7	100,00	SW040	63A	4	3118
13,1	43	1,3	100,00	SW050	63A	4	4280
12,1	67	3,1	71,25	HA31+SW063	63B	6	5878
12,1	61	3,9	116,00	HA31+SW063	63A	4	5965
12,1	64	3,8	109,09	HA31+SW063	63A	4	5844
12,1	66	4,0	109,09	HA31+SW075	63A	4	6898
11,1	70	3,5	77,33	HA31+SW063	63B	6	6041
11,1	77	2,8	81,82	HA31+SW063	63B	6	6155
11,1	72	3,6	77,33	HA31+SW075	63B	6	7130
11,1	52	1,3	80,00	SW050	63B	6	4604
11,1	71	3,0	127,50	HA31+SW063	63A	4	6156
10,1	71	3,5	88,33	HA31+SW063	63B	6	6270
10,1	75	3,9	83,93	HA31+SW075	63B	6	7327
9,1	85	2,9	95,00	HA31+SW063	63B	6	6270
9,1	59	0,9	100,00	SW050	63B	6	4840
9,1	73	3,4	142,50	HA31+SW063	63A	4	6270
9,1	90	2,6	157,50	HA31+SW063	63A	4	6270
9,0	73	1,0	150,00	SW030/040	63A	4	3169
9,0	73	1,8	150,00	SW030/050	63A	4	4350
9,0	75	2,0	150,00	SW030/063	63A	4	4967
8,1	91	2,7	102,00	HA31+SW063	63B	6	6270
8,1	98	2,6	109,09	HA31+SW063	63B	6	6270
8,1	101	2,8	109,09	HA31+SW075	63B	6	7380
8,1	81	2,8	168,57	HA31+SW063	63A	4	6270
8,1	82	3,7	176,67	HA31+SW075	63A	4	7380
8,1	87	4,0	163,64	HA31+SW075	63A	4	7380
7,1	91	2,9	116,00	HA31+SW063	63B	6	6270
7,1	109	2,1	127,50	HA31+SW063	63B	6	6270
7,1	96	2,5	204,00	HA31+SW063	63A	4	6270
7,1	95	2,8	189,00	HA31+SW063	63A	4	6270
7,1	91	3,7	193,33	HA31+SW075	63A	4	7380
6,8	93	1,3	200,00	SW030/050	63A	4	4788
6,8	95	1,5	200,00	SW030/063	63A	4	4967



## 0,12 kW

n2 [rpm]	M2 [Nm]	fs	i	Gear reducer	Size	Motor Pole	Fr2 [N]
6,8	105	3,3	200,00	SW040/090	63A	4	6487
6,1	111	2,4	142,50	HA31+SW063	63B	6	6270
6,1	103	3,8	134,29	HA31+SW075	63B	6	7380
6,1	118	3,4	154,67	HA31+SW075	63B	6	7380
6,1	117	3,1	142,50	HA31+SW075	63B	6	7380
6,1	109	3,9	134,29	HA31+SW090	63B	6	8180
6,0	102	2,4	218,18	HA31+SW063	63A	4	6270
6,0	119	2,3	236,25	HA31+SW063	63A	4	6270
6,0	109	3,2	237,50	HA31+SW075	63A	4	7380
6,0	107	3,7	218,18	HA31+SW075	63A	4	7380
6,0	113	4,0	218,18	HA31+SW090	63A	4	8180
5,4	109	1,0	250,00	SW030/050	63A	4	4840
5,4	111	1,6	250,00	SW030/063	63A	4	4967
5,4	119	3,2	250,00	SW040/075	63A	4	7380
5,1	122	2,1	168,57	HA31+SW063	63B	6	6270
5,1	141	1,8	157,50	HA31+SW063	63B	6	6270
5,1	133	2,8	163,64	HA31+SW075	63B	6	7380
5,1	128	3,9	167,86	HA31+SW090	63B	6	8180
5,0	120	2,7	176,67	HA31+SW075	63B	6	7380
4,9	119	1,9	272,73	HA31+SW063	63A	4	6270
4,9	124	2,9	272,73	HA31+SW075	63A	4	7380
4,9	133	4,0	272,73	HA31+SW090	63A	4	8180
4,7	147	1,8	189,00	HA31+SW063	63B	6	6270
4,5	121	1,2	300,00	SW030/050	63A	4	4840
4,5	116	2,2	300,00	SW030/063	63A	4	6270
4,5	133	3,3	300,00	SW040/075	63A	4	7380
4,5	135	2,7	193,33	HA31+SW075	63B	6	7380
4,5	145	3,6	193,33	HA31+SW090	63B	6	8180
4,4	140	3,5	306,00	HA31+SW090	63A	4	8180
4,3	142	3,4	201,43	HA31+SW090	63B	6	8180
4,3	145	1,7	315,00	HA31+SW063	63A	4	6270
4,3	153	2,6	315,00	HA31+SW075	63A	4	7380
4,2	146	1,7	204,00	HA31+SW063	63B	6	6270
4,1	149	3,3	327,27	HA31+SW090	63A	4	8180
3,9	156	1,6	218,18	HA31+SW063	63B	6	6270
3,9	164	2,5	218,18	HA31+SW075	63B	6	7380
3,9	173	2,8	218,18	HA31+SW090	63B	6	8180
3,6	184	1,5	236,25	HA31+SW063	63B	6	6270
3,6	164	2,2	237,50	HA31+SW075	63B	6	7380
3,6	176	3,1	237,50	HA31+SW090	63B	6	8180
3,5	158	2,7	380,00	HA31+SW090	63A	4	8180
3,4	189	2,9	255,00	HA31+SW090	63B	6	8180

## 0,12 kW

n2 [rpm]	M2 [Nm]	fs	i	Gear reducer	Motor		Fr2 [N]
					Size	Pole	
3,4	169	1,4	393,75	HA31+SW063	63A	4	6270
3,4	175	2,1	393,75	HA31+SW075	63A	4	7380
3,4	146	0,8	400,00	SW030/050	63A	4	4840
3,4	151	1,7	400,00	SW030/063	63A	4	6270
3,4	163	2,5	400,00	SW040/075	63A	4	7380
3,4	172	3,5	400,00	SW040/090	63A	4	8180
3,3	169	2,6	408,00	HA31+SW090	63A	4	8180
3,2	181	1,3	272,73	HA31+SW063	63B	6	6270
3,2	188	1,9	272,73	HA31+SW075	63B	6	7380
3,2	202	2,7	272,73	HA31+SW090	63B	6	8180
3,1	200	1,2	433,33	HA31+SW063	63A	4	6270
3,1	180	2,4	436,36	HA31+SW090	63A	4	8180
2,8	212	2,4	306,00	HA31+SW090	63B	6	8180
2,8	187	1,2	472,50	HA31+SW063	63A	4	6270
2,8	199	1,7	472,50	HA31+SW075	63A	4	7380
2,8	210	2,4	472,50	HA31+SW090	63A	4	8180
2,7	225	1,1	315,00	HA31+SW063	63B	6	6270
2,7	237	1,7	315,00	HA31+SW075	63B	6	7380
2,7	169	0,7	500,00	SW030/050	63A	4	4840
2,7	176	1,3	500,00	SW030/063	63A	4	6270
2,7	187	2,0	500,00	SW040/075	63A	4	7380
2,7	201	2,8	500,00	SW040/090	63A	4	8180
2,6	225	2,2	327,27	HA31+SW090	63B	6	8180
2,6	191	2,0	510,00	HA31+SW090	63A	4	8180
2,5	232	1,0	541,67	HA31+SW063	63A	4	6270
2,5	241	1,2	541,67	HA31+SW075	63A	4	7380
2,5	202	1,9	545,45	HA31+SW090	63A	4	8180
2,3	238	1,9	380,00	HA31+SW090	63B	6	8180
2,2	220	1,2	600,00	SW030/063	63A	4	6270
2,2	246	1,8	600,00	SW040/075	63A	4	7380
2,2	258	2,7	600,00	SW040/090	63A	4	8180
2,2	262	0,9	393,75	HA31+SW063	63B	6	6270
2,2	272	1,3	393,75	HA31+SW075	63B	6	7380
2,1	255	1,8	408,00	HA31+SW090	63B	6	8180
2,1	257	0,8	650,00	HA31+SW063	63A	4	6270
2,1	273	1,2	650,00	HA31+SW075	63A	4	7380
2,1	254	1,8	630,00	HA31+SW090	63A	4	8180
2,1	289	1,2	650,00	HA31+SW090	63A	4	8180
2,0	310	0,8	433,33	HA31+SW063	63B	6	6270
2,0	273	1,7	436,36	HA31+SW090	63B	6	8180
1,8	290	0,7	472,50	HA31+SW063	63B	6	6270
1,8	307	1,1	472,50	HA31+SW075	63B	6	7380

## 0,12 kW

n2 [rpm]	M2 [Nm]	fs	i	Gear reducer	Size	Motor Pole	Fr2 [N]
1,8	326	1,5	472,50	HA31+SW090	63B	6	8180
1,8	256	1,0	750,00	SW030/063	63A	4	6270
1,8	297	1,5	750,00	SW040/075	63A	4	7380
1,8	311	2,2	750,00	SW040/090	63A	4	8180
1,7	287	1,4	510,00	HA31+SW090	63B	6	8180
1,7	259	0,9	787,50	HA31+SW075	63A	4	7380
1,7	285	1,4	787,50	HA31+SW090	63A	4	8180
1,6	374	0,9	541,67	HA31+SW075	63B	6	7380
1,6	306	1,3	545,45	HA31+SW090	63B	6	8180
1,5	322	0,9	866,67	HA31+SW075	63A	4	7380
1,5	349	1,2	866,67	HA31+SW090	63A	4	8180
1,5	295	0,9	900,00	SW030/063	63A	4	6270
1,5	333	1,3	900,00	SW040/075	63A	4	7380
1,5	347	2,0	900,00	SW040/090	63A	4	8180
1,4	394	1,2	630,00	HA31+SW090	63B	6	8180
1,3	423	0,8	650,00	HA31+SW075	63B	6	7380
1,3	449	0,9	650,00	HA31+SW090	63B	6	8180
1,1	357	0,8	1200,00	SW030/063	63A	4	6270
1,1	412	1,1	1200,00	SW040/075	63A	4	7380
1,1	431	1,6	1200,00	SW040/090	63A	4	8180
1,1	445	1,6	1200,00	SW050/090	63A	4	8180
1,1	445	2,5	1200,00	SW050/105	63A	4	10320
1,1	443	0,9	787,50	HA31+SW090	63B	6	8180
1,0	543	0,8	866,67	HA31+SW090	63B	6	8180
0,9	491	0,9	1500,00	SW040/075	63A	4	7380
0,9	514	1,4	1500,00	SW040/090	63A	4	8180
0,9	523	1,3	1500,00	SW050/090	63A	4	8180
0,9	523	2,1	1500,00	SW050/105	63A	4	10320
0,7	552	0,8	1800,00	SW040/075	63A	4	7380
0,7	578	1,2	1800,00	SW040/090	63A	4	8180
0,7	588	1,2	1800,00	SW050/090	63A	4	8180
0,7	588	1,9	1800,00	SW050/105	63A	4	10320
0,6	714	0,8	2400,00	SW040/090	63A	4	8180
0,6	726	0,8	2400,00	SW050/090	63A	4	8180
0,6	760	1,3	2400,00	SW050/105	63A	4	10320
0,5	907	1,1	3000,00	SW050/105	63A	4	10320
0,3	1088	0,9	4000,00	SW050/105	63A	4	10320
0,3	1260	0,8	5000,00	SW050/105	63A	4	10320

## 0,18 kW

n2 [rpm]	M2 [Nm]	fs	i	Gear reducer	Motor		Fr2 [N]
					Size	Pole	
377,0	4	3,2	7,50	SW030	63A	2	542
283,0	5	2,5	10,00	SW030	63A	2	597
272,0	6	3,5	5,00	SW030	63B	4	597
189,0	8	1,7	15,00	SW030	63A	2	683
189,0	8	4,0	15,00	SW040	63A	2	1315
181,0	8	2,4	7,50	SW030	63B	4	683
141,5	10	1,2	20,00	SW030	63A	2	752
141,5	10	2,8	20,00	SW040	63A	2	1447
136,0	11	1,8	10,00	SW030	63B	4	752
120,0	12	3,8	7,50	SW040	71A	6	1524
113,2	12	1,4	25,00	SW030	63A	2	810
113,2	12	2,3	25,00	SW040	63A	2	1559
94,0	13	1,1	30,00	SW030	63A	2	861
94,0	14	2,4	30,00	SW040	63A	2	1657
91,0	15	1,3	15,00	SW030	63B	4	861
91,0	16	2,8	15,00	SW040	63B	4	1657
90,0	16	3,0	10,00	SW040	71A	6	1677
70,8	16	0,9	40,00	SW030	63A	2	948
70,8	18	1,7	40,00	SW040	63A	2	1824
70,8	18	3,2	40,00	SW050	63A	2	2503
68,5	19	0,9	20,00	SW030	63B	4	948
68,5	20	2,1	20,00	SW040	63B	4	1824
60,0	23	2,2	15,00	SW040	71A	6	1920
57,3	25	4,0	23,82	HA31+SW063	63B	4	3528
56,6	21	1,4	50,00	SW040	63A	2	1964
56,6	21	2,5	50,00	SW050	63A	2	2696
54,2	22	1,0	25,00	SW030	63B	4	1021
54,2	24	1,6	25,00	SW040	63B	4	1964
47,5	24	1,2	60,00	SW040	63A	2	2087
47,5	25	2,0	60,00	SW050	63A	2	2865
45,0	29	1,7	20,00	SW040	71A	6	2113
45,0	29	2,8	20,00	SW050	71A	6	2900
45,0	25	0,8	30,00	SW030	63B	4	1085
45,0	27	1,7	30,00	SW040	63B	4	2087
38,0	37	2,9	23,82	HA31+SW063	71A	6	4018
36,0	35	1,3	25,00	SW040	71A	6	2276
36,0	35	2,2	25,00	SW050	71A	6	3124
35,4	29	0,8	80,00	SW040	63A	2	2298
35,4	30	1,5	80,00	SW050	63A	2	3153
34,8	38	3,5	38,67	HA31+SW063	63B	4	4146
33,7	33	1,3	40,00	SW040	63B	4	2298
33,7	34	2,4	40,00	SW050	63B	4	3153

## 0,18 kW

n2 [rpm]	M2 [Nm]	fs	i	Gear reducer	Size	Motor Pole	Fr2 [N]
31,0	44	3,1	29,44	HA31+SW063	71A	6	4312
30,0	38	1,4	30,00	SW040	71A	6	2419
30,0	40	2,4	30,00	SW050	71A	6	3320
28,6	47	3,0	47,50	HA31+SW063	63B	4	4440
28,3	35	1,1	100,00	SW050	63A	2	3397
27,6	40	1,0	50,00	SW040	63B	4	2475
27,6	40	1,9	50,00	SW050	63B	4	3397
23,5	54	3,7	58,89	HA31+SW063	63B	4	4770
23,0	57	2,5	38,67	HA31+SW063	71A	6	4722
23,0	48	1,0	40,00	SW040	71A	6	2662
23,0	49	1,8	40,00	SW050	71A	6	3654
23,0	50	3,4	40,00	SW063	71A	6	4776
22,5	45	0,8	60,00	SW040	63B	4	2630
22,5	46	1,5	60,00	SW050	63B	4	3610
20,0	62	3,1	44,17	HA31+SW063	71A	6	4937
19,4	66	3,0	71,25	HA31+SW063	63B	4	5083
19,0	70	2,1	47,50	HA31+SW063	71A	6	5058
18,0	57	1,4	50,00	SW050	71A	6	3936
18,0	59	2,7	50,00	SW063	71A	6	5145
17,4	68	3,2	77,33	HA31+SW063	63B	4	5224
17,4	70	3,5	77,33	HA31+SW075	63B	4	6166
17,4	55	1,2	80,00	SW050	63B	4	3973
16,4	75	2,7	81,82	HA31+SW063	63B	4	5323
16,4	74	3,8	83,93	HA31+SW075	63B	4	6336
15,3	71	3,1	88,33	HA31+SW063	63B	4	5460
15,0	78	3,0	58,89	HA31+SW063	71A	6	5433
15,0	64	1,2	60,00	SW050	71A	6	4183
15,0	68	2,3	60,00	SW063	71A	6	5467
15,0	71	3,5	60,00	SW075	71A	6	6453
14,3	83	2,8	95,00	HA31+SW063	63B	4	5595
14,3	79	4,0	95,29	HA31+SW075	63B	4	6610
13,6	76	0,9	100,00	SW030/040	63B	4	2769
13,6	79	1,7	100,00	SW030/050	63B	4	3800
13,6	79	1,9	100,00	SW030/063	63B	4	4967
13,3	89	2,7	102,00	HA31+SW063	63B	4	5729
13,3	64	0,9	100,00	SW050	63B	4	4280
13,0	98	2,1	71,25	HA31+SW063	71A	6	5790
12,3	95	2,6	109,09	HA31+SW063	63B	4	5858
12,3	98	2,7	109,09	HA31+SW075	63B	4	6915
12,0	101	2,4	77,33	HA31+SW063	71A	6	5950
12,0	104	2,5	77,33	HA31+SW075	71A	6	7023
11,2	91	2,7	116,00	HA31+SW063	63B	4	5980

## 0,18 kW

n2 [rpm]	M2 [Nm]	fs	i	Gear reducer	Size	Motor Pole	Fr2 [N]
11,2	92	3,8	117,78	HA31+SW075	63B	4	7094
11,0	112	1,9	81,82	HA31+SW063	71A	6	6063
11,0	109	2,8	83,93	HA31+SW075	71A	6	7217
11,0	76	0,9	80,00	SW050	71A	6	4604
11,0	81	1,7	80,00	SW063	71A	6	6018
11,0	86	2,6	80,00	SW075	71A	6	7103
10,2	107	2,0	127,50	HA31+SW063	63B	4	6171
10,2	103	3,5	134,29	HA31+SW075	63B	4	7380
10,2	108	3,8	134,29	HA31+SW090	63B	4	8180
10,0	103	2,4	88,33	HA31+SW063	71A	6	6220
9,2	110	2,4	142,50	HA31+SW063	63B	4	6270
9,2	117	3,2	154,67	HA31+SW075	63B	4	7380
9,2	114	3,0	142,50	HA31+SW075	63B	4	7380
9,1	110	1,2	150,00	SW030/050	63B	4	4350
9,1	111	1,3	150,00	SW030/063	63B	4	4967
9,1	116	3,7	150,00	SW040/075	63B	4	6712
9,1	122	3,0	150,00	SW040/090	63B	4	6487
9,0	123	2,1	95,00	HA31+SW063	71A	6	6270
9,0	132	1,9	102,00	HA31+SW063	71A	6	6270
9,0	115	2,9	95,29	HA31+SW075	71A	6	7380
9,0	122	3,4	102,00	HA31+SW090	71A	6	8180
9,0	92	1,4	100,00	SW063	71A	6	6270
9,0	97	2,0	100,00	SW075	71A	6	7380
8,2	121	1,9	168,57	HA31+SW063	63B	4	6270
8,2	135	1,7	157,50	HA31+SW063	63B	4	6270
8,2	122	2,5	176,67	HA31+SW075	63B	4	7380
8,2	130	2,7	163,64	HA31+SW075	63B	4	7380
8,2	122	4,0	158,82	HA31+SW090	63B	4	8180
8,2	128	3,8	167,86	HA31+SW090	63B	4	8180
8,0	132	2,0	116,00	HA31+SW063	71A	6	6270
8,0	141	1,8	109,09	HA31+SW063	71A	6	6270
8,0	133	2,9	117,78	HA31+SW075	71A	6	7380
8,0	146	1,9	109,09	HA31+SW075	71A	6	7380
8,0	139	3,1	117,78	HA31+SW090	71A	6	8180
7,2	144	1,7	204,00	HA31+SW063	63B	4	6270
7,2	142	1,8	189,00	HA31+SW063	63B	4	6270
7,2	136	2,5	193,33	HA31+SW075	63B	4	7380
7,2	144	3,2	201,43	HA31+SW090	63B	4	8180
7,2	145	3,5	193,33	HA31+SW090	63B	4	8180
7,0	158	1,5	127,50	HA31+SW063	71A	6	6270
7,0	150	2,7	134,29	HA31+SW075	71A	6	7380
7,0	144	3,4	127,50	HA31+SW090	71A	6	8180

## 0,18 kW

n2 [rpm]	M2 [Nm]	fs	i	Gear reducer	Motor		Fr2 [N]
					Size	Pole	
7,0	157	2,8	134,29	HA31+SW090	71A	6	8180
6,8	138	0,9	200,00	SW030/050	63B	4	4788
6,8	141	1,0	200,00	SW030/063	63B	4	4967
6,8	147	2,9	200,00	SW040/075	63B	4	7380
6,8	155	2,2	200,00	SW040/090	63B	4	6487
6,1	153	1,6	218,18	HA31+SW063	63B	4	6270
6,1	177	1,5	236,25	HA31+SW063	63B	4	6270
6,1	162	2,1	237,50	HA31+SW075	63B	4	7380
6,1	160	2,5	218,18	HA31+SW075	63B	4	7380
6,1	174	3,0	237,50	HA31+SW090	63B	4	8180
6,1	168	2,7	218,18	HA31+SW090	63B	4	8180
6,0	161	1,7	142,50	HA31+SW063	71A	6	6270
6,0	204	1,2	157,50	HA31+SW063	71A	6	6270
6,0	171	2,4	154,67	HA31+SW075	71A	6	7380
6,0	169	2,1	142,50	HA31+SW075	71A	6	7380
6,0	194	1,9	163,64	HA31+SW075	71A	6	7380
6,0	164	3,1	147,22	HA31+SW090	71A	6	8180
6,0	176	2,9	158,82	HA31+SW090	71A	6	8180
5,4	163	1,0	250,00	SW030/063	63B	4	4967
5,4	176	2,1	250,00	SW040/075	63B	4	7380
5,4	184	3,1	250,00	SW040/090	63B	4	8180
5,1	186	2,9	255,00	HA31+SW090	63B	4	8180
5,0	177	1,3	272,73	HA31+SW063	63B	4	6270
5,0	185	1,9	272,73	HA31+SW075	63B	4	7380
5,0	198	2,7	272,73	HA31+SW090	63B	4	8180
5,0	176	1,4	168,57	HA31+SW063	71A	6	6270
5,0	174	1,9	176,67	HA31+SW075	71A	6	7380
5,0	185	2,8	167,86	HA31+SW090	71A	6	8180
4,8	214	1,3	189,00	HA31+SW063	71A	6	6270
4,7	196	1,8	193,33	HA31+SW075	71A	6	7380
4,7	210	2,5	193,33	HA31+SW090	71A	6	8180
4,5	179	0,8	300,00	SW030/050	63B	4	4840
4,5	171	1,5	300,00	SW030/063	63B	4	6270
4,5	196	2,2	300,00	SW040/075	63B	4	7380
4,5	205	3,4	300,00	SW040/090	63B	4	8180
4,5	207	2,4	201,43	HA31+SW090	71A	6	8180
4,4	212	1,2	204,00	HA31+SW063	71A	6	6270
4,4	208	2,4	306,00	HA31+SW090	63B	4	8180
4,3	216	1,2	315,00	HA31+SW063	63B	4	6270
4,3	228	1,7	315,00	HA31+SW075	63B	4	7380
4,2	221	2,2	327,27	HA31+SW090	63B	4	8180
4,1	226	1,1	218,18	HA31+SW063	71A	6	6270

## 0,18 kW

n2 [rpm]	M2 [Nm]	fs	i	Gear reducer	Motor		Fr2 [N]
					Size	Pole	
4,1	238	1,7	218,18	HA31+SW075	71A	6	7380
4,1	251	1,9	218,18	HA31+SW090	71A	6	8180
3,8	267	1,0	236,25	HA31+SW063	71A	6	6270
3,8	238	1,5	237,50	HA31+SW075	71A	6	7380
3,8	255	2,1	237,50	HA31+SW090	71A	6	8180
3,6	236	1,8	380,00	HA31+SW090	63B	4	8180
3,5	274	2,0	255,00	HA31+SW090	71A	6	8180
3,5	251	0,9	393,75	HA31+SW063	63B	4	6270
3,5	261	1,4	393,75	HA31+SW075	63B	4	7380
3,4	223	1,1	400,00	SW030/063	63B	4	6270
3,4	241	1,7	400,00	SW040/075	63B	4	7380
3,4	253	2,5	400,00	SW040/090	63B	4	8180
3,4	251	1,7	408,00	HA31+SW090	63B	4	8180
3,3	263	0,9	272,73	HA31+SW063	71A	6	6270
3,3	273	1,3	272,73	HA31+SW075	71A	6	7380
3,3	293	1,9	272,73	HA31+SW090	71A	6	8180
3,2	297	0,8	433,33	HA31+SW063	63B	4	6270
3,1	267	1,6	436,36	HA31+SW090	63B	4	8180
2,9	327	0,8	315,00	HA31+SW063	71A	6	6270
2,9	344	1,2	315,00	HA31+SW075	71A	6	7380
2,9	306	1,6	306,00	HA31+SW090	71A	6	8180
2,9	278	0,8	472,50	HA31+SW063	63B	4	6270
2,9	295	1,1	472,50	HA31+SW075	63B	4	7380
2,9	313	1,6	472,50	HA31+SW090	63B	4	8180
2,8	327	1,5	327,27	HA31+SW090	71A	6	8180
2,7	259	0,9	500,00	SW030/063	63B	4	6270
2,7	276	1,3	500,00	SW040/075	63B	4	7380
2,7	296	1,9	500,00	SW040/090	63B	4	8180
2,7	285	1,3	510,00	HA31+SW090	63B	4	8180
2,6	359	0,8	541,67	HA31+SW075	63B	4	7380
2,5	302	1,3	545,45	HA31+SW090	63B	4	8180
2,4	345	1,3	380,00	HA31+SW090	71A	6	8180
2,3	394	0,9	393,75	HA31+SW075	71A	6	7380
2,3	326	0,8	600,00	SW030/063	63B	4	6270
2,3	364	1,2	600,00	SW040/075	63B	4	7380
2,3	381	1,8	600,00	SW040/090	63B	4	8180
2,2	370	1,2	408,00	HA31+SW090	71A	6	8180
2,1	378	1,2	630,00	HA31+SW090	63B	4	8180
2,1	396	1,2	436,36	HA31+SW090	71A	6	8180
2,0	407	0,8	650,00	HA31+SW075	63B	4	7380
2,0	430	0,8	650,00	HA31+SW090	63B	4	8180
1,9	446	0,8	472,50	HA31+SW075	71A	6	7380



## 0,18 kW

n2 [rpm]	M2 [Nm]	fs	i	Gear reducer	Motor		Fr2 [N]
					Size	Pole	
1,9	473	1,1	472,50	HA31+SW090	71A	6	8180
1,8	438	1,0	750,00	SW040/075	63B	4	7380
1,8	459	1,5	750,00	SW040/090	63B	4	8180
1,8	416	1,0	510,00	HA31+SW090	71A	6	8180
1,7	424	0,9	787,50	HA31+SW090	63B	4	8180
1,7	445	0,9	545,45	HA31+SW090	71A	6	8180
1,5	520	0,8	866,67	HA31+SW090	63B	4	8180
1,5	491	0,9	900,00	SW040/075	63B	4	7380
1,5	514	1,3	900,00	SW040/090	63B	4	8180
1,4	572	0,8	630,00	HA31+SW090	71A	6	8180
1,1	608	0,7	1200,00	SW040/075	63B	4	7380
1,1	638	1,1	1200,00	SW040/090	63B	4	8180
1,1	656	1,0	1200,00	SW050/090	63B	4	8180
1,1	656	1,6	1200,00	SW050/105	63B	4	10320
0,9	760	0,9	1500,00	SW040/090	63B	4	8180
0,9	773	0,9	1500,00	SW050/090	63B	4	8180
0,9	773	1,4	1500,00	SW050/105	63B	4	10320
0,8	855	0,8	1800,00	SW040/090	63B	4	8180
0,8	868	0,8	1800,00	SW050/090	63B	4	8180
0,8	868	1,2	1800,00	SW050/105	63B	4	10320
0,6	1124	0,9	2400,00	SW050/105	63B	4	10320
0,4	1340	0,7	3000,00	SW050/105	63B	4	10320

## 0,25 kW

n2 [rpm]	M2 [Nm]	fs	i	Gear reducer	Motor		Fr2 [N]
					Size	Pole	
564,0	4	3,2	5,00	SW030	63B	2	474
375,7	6	2,3	7,50	SW030	63B	2	542
282,0	7	1,8	10,00	SW030	63B	2	597
282,0	8	3,9	10,00	SW040	63B	2	1149
270,0	8	2,5	5,00	SW030	63D	4	597
188,3	10	1,2	15,00	SW030	63B	2	683
188,3	11	2,9	15,00	SW040	63B	2	1315
182,0	12	3,6	5,00	SW040	71B	6	1331
180,0	12	1,6	7,50	SW030	63D	4	683
180,0	12	3,7	7,50	SW040	63D/71A	4	1315
141,0	13	0,9	20,00	SW030	63B	2	752
141,0	14	2,0	20,00	SW040	63B	2	1447
138,0	15	3,0	10,00	SW040	63D/71A	4	1447
135,0	15	1,3	10,00	SW030	63D	4	752
121,3	17	2,7	7,50	SW040	71B	6	1524
112,8	16	1,0	25,00	SW030	63B	2	810

## 0,25 kW

n2 [rpm]	M2 [Nm]	fs	i	Gear reducer	Motor		Fr2 [N]
					Size	Pole	
112,8	17	1,6	25,00	SW040	63B	2	1559
93,7	18	0,8	30,00	SW030	63B	2	861
93,7	20	1,7	30,00	SW040	63B	2	1657
92,3	21	3,8	15,00	SW050	71A	4	2274
91,0	22	2,2	10,00	SW040	71B	6	1677
90,0	21	0,9	15,00	SW030	63D	4	861
90,0	22	2,0	15,00	SW040	63D/71A	4	1657
70,5	25	1,2	40,00	SW040	63B	2	1824
70,5	25	2,3	40,00	SW050	63B	2	2503
69,5	27	2,8	20,00	SW050	71A	4	2503
67,5	28	1,5	20,00	SW040	63D/71A	4	1824
60,7	31	1,6	15,00	SW040	71B	6	1920
60,7	32	2,9	15,00	SW050	71B	6	2635
56,4	29	1,0	50,00	SW040	63B	2	1964
56,4	30	1,8	50,00	SW050	63B	2	2696
56,2	35	2,9	23,82	HA31+SW063	63D/71A	4	3537
55,6	33	2,1	25,00	SW050	71A	4	2696
54,2	30	0,7	25,00	SW030	63D	4	1021
54,2	33	1,1	25,00	SW040	63D/71A	4	1964
47,3	34	0,8	60,00	SW040	63B	2	2087
47,3	34	1,5	60,00	SW050	63B	2	2865
46,0	41	3,1	29,44	HA31+SW063	63D/71A	4	3796
45,7	38	2,3	30,00	SW050	71A	4	2865
45,5	40	1,2	20,00	SW040	71B	6	2113
45,5	41	2,0	20,00	SW050	71B	6	2900
45,0	38	1,2	30,00	SW040	63D/71A	4	2087
38,4	50	2,1	23,82	HA31+SW063	71B	6	4018
36,4	47	0,9	25,00	SW040	71B	6	2276
36,4	48	1,5	25,00	SW050	71B	6	3124
35,2	42	1,1	80,00	SW050	63B	2	3153
34,8	54	2,5	38,67	HA31+SW063	63D/71A	4	4156
34,7	49	3,0	40,00	SW063	71A	4	4122
33,8	47	0,9	40,00	SW040	63D/71A	4	2298
33,8	48	1,7	40,00	SW050	63D/71A	4	3153
31,3	60	2,3	29,44	HA31+SW063	71B	6	4312
30,7	59	3,1	44,17	HA31+SW063	63D/71A	4	4345
30,3	52	1,0	30,00	SW040	71B	6	2419
30,3	54	1,7	30,00	SW050	71B	6	3320
28,6	66	2,1	47,50	HA31+SW063	63D/71A	4	4452
28,2	49	0,8	100,00	SW050	63B	2	3397
27,8	58	2,5	50,00	SW063	71A	4	4440
27,8	60	3,7	50,00	SW075	71A	4	5241

## 0,25 kW

n <sub>2</sub> [rpm]	M <sub>2</sub> [Nm]	f <sub>s</sub>	i	Gear reducer	Motor		Fr <sub>2</sub> [N]
					Size	Pole	
26,6	56	0,7	50,00	SW040	63D	4	2475
26,6	57	1,3	50,00	SW050	63D/71A	4	3397
23,3	78	1,8	38,67	HA31+SW063	71B	6	4722
23,3	66	0,7	40,00	SW040	71B	6	2662
23,3	67	1,3	40,00	SW050	71B	6	3654
23,3	69	2,4	40,00	SW063	71B	6	4776
22,8	65	2,1	60,00	SW063	71A	4	4719
22,8	68	3,1	60,00	SW075	71A	4	5569
22,5	75	2,7	58,89	HA31+SW063	63D/71A	4	4782
22,5	64	1,1	60,00	SW050	63D/71A	4	3610
20,2	85	2,3	44,17	HA31+SW063	71B	6	4937
19,4	92	2,1	71,25	HA31+SW063	63D/71A	4	5096
19,2	96	1,5	47,50	HA31+SW063	71B	6	5058
18,2	79	1,0	50,00	SW050	71B	6	3936
18,2	81	2,0	50,00	SW063	71B	6	5145
18,2	84	3,0	50,00	SW075	71B	6	6073
17,4	97	2,2	77,33	HA31+SW063	63D/71A	4	5237
17,4	99	2,5	77,33	HA31+SW075	63D/71A	4	6181
17,4	76	0,8	80,00	SW050	63D/71A	4	3973
16,9	81	1,5	80,00	SW063	71A	4	5193
16,9	85	2,3	80,00	SW075	71A	4	6130
16,4	105	1,9	81,82	HA31+SW063	63D/71A	4	5336
16,4	105	2,7	83,93	HA31+SW075	63D/71A	4	6352
15,3	100	2,1	88,33	HA31+SW063	63D/71A	4	5474
15,2	108	2,1	58,89	HA31+SW063	71B	6	5433
15,2	88	0,9	60,00	SW050	71B	6	4183
15,2	93	1,6	60,00	SW063	71B	6	5467
15,2	98	2,5	60,00	SW075	71B	6	6453
14,3	116	2,0	95,00	HA31+SW063	63D/71A	4	5609
14,3	111	2,9	95,29	HA31+SW075	63D/71A	4	6627
13,9	90	1,3	100,00	SW063	71A	4	5595
13,9	97	1,9	100,00	SW075	71A	4	6603
13,8	117	3,0	100,00	SW040/075	63D/71A	4	5863
13,8	120	3,0	100,00	SW040/090	63D/71A	4	6487
13,5	110	1,2	100,00	SW030/050	63D	4	3800
13,5	110	1,3	100,00	SW030/063	63D	4	4967
13,3	124	1,9	102,00	HA31+SW063	63D/71A	4	5743
13,3	118	3,4	102,00	HA31+SW090	63D/71A	4	7501
13,1	135	1,5	71,25	HA31+SW063	71B	6	5790
12,3	133	1,8	109,09	HA31+SW063	63D/71A	4	5873
12,3	137	1,9	109,09	HA31+SW075	63D/71A	4	6932
12,1	138	1,8	77,33	HA31+SW063	71B	6	5950

## 0,25 kW

n2 [rpm]	M2 [Nm]	fs	i	Gear reducer	Motor		Fr2 [N]
					Size	Pole	
12,1	142	1,8	77,33	HA31+SW075	71B	6	7023
11,2	127	1,8	116,00	HA31+SW063	63D/71A	4	5995
11,2	128	2,7	117,78	HA31+SW075	63D/71A	4	7112
11,2	135	3,1	117,78	HA31+SW090	63D/71A	4	7869
11,1	154	1,4	81,82	HA31+SW063	71B	6	6063
11,1	149	2,0	83,93	HA31+SW075	71B	6	7217
11,1	111	1,2	80,00	SW063	71B	6	6018
11,1	118	1,9	80,00	SW075	71B	6	7103
10,2	150	1,4	127,50	HA31+SW063	63D/71A	4	6187
10,2	145	2,5	134,29	HA31+SW075	63D/71A	4	7380
10,2	142	3,4	127,50	HA31+SW090	63D/71A	4	8080
10,2	152	2,7	134,29	HA31+SW090	63D/71A	4	8180
10,1	141	1,8	88,33	HA31+SW063	71B	6	6220
9,2	153	1,6	142,50	HA31+SW063	63D/71A	4	6270
9,2	163	2,2	154,67	HA31+SW075	63D/71A	4	7380
9,2	160	2,1	142,50	HA31+SW075	63D/71A	4	7380
9,2	160	3,1	147,22	HA31+SW090	63D/71A	4	8180
9,2	166	2,6	150,00	SW040/075	63D/71A	4	6712
9,2	175	2,1	150,00	SW040/090	63D/71A	4	6487
9,2	175	3,8	150,00	SW050/090	71A	4	7426
9,1	169	1,5	95,00	HA31+SW063	71B	6	6270
9,1	182	1,4	102,00	HA31+SW063	71B	6	6270
9,1	158	2,1	95,29	HA31+SW075	71B	6	7380
9,1	167	2,5	102,00	HA31+SW090	71B	6	8180
9,1	126	1,0	100,00	SW063	71B	6	6270
9,1	134	1,4	100,00	SW075	71B	6	7380
9,0	152	0,9	150,00	SW030/050	63D	4	4350
9,0	154	1,0	150,00	SW030/063	63D	4	4967
8,2	169	1,3	168,57	HA31+SW063	63D/71A	4	6270
8,2	189	1,2	157,50	HA31+SW063	63D/71A	4	6270
8,2	182	1,9	163,64	HA31+SW075	63D/71A	4	7380
8,2	171	2,9	158,82	HA31+SW090	63D/71A	4	8180
8,2	180	2,7	167,86	HA31+SW090	63D/71A	4	8180
8,1	182	1,4	116,00	HA31+SW063	71B	6	6270
8,1	194	1,3	109,09	HA31+SW063	71B	6	6270
8,1	182	2,1	117,78	HA31+SW075	71B	6	7380
8,1	200	1,4	109,09	HA31+SW075	71B	6	7380
8,1	191	2,3	117,78	HA31+SW090	71B	6	8180
7,2	198	1,3	189,00	HA31+SW063	63D/71A	4	6270
7,2	171	1,7	176,67	HA31+SW075	63D/71A	4	7380
7,2	190	1,7	193,33	HA31+SW075	63D/71A	4	7380
7,2	201	2,2	201,43	HA31+SW090	63D/71A	4	8180

## 0,25 kW

n2 [rpm]	M2 [Nm]	fs	i	Gear reducer	Motor		Fr2 [N]
					Size	Pole	
7,2	203	2,5	193,33	HA31+SW090	63D/71A	4	8180
7,1	218	1,1	127,50	HA31+SW063	71B	6	6270
7,1	206	1,9	134,29	HA31+SW075	71B	6	7380
7,1	198	2,5	127,50	HA31+SW090	71B	6	8180
7,1	216	2,0	134,29	HA31+SW090	71B	6	8180
6,9	211	2,0	200,00	SW040/075	63D/71A	4	7380
6,9	223	1,6	200,00	SW040/090	63D/71A	4	6487
6,9	225	2,7	200,00	SW050/090	71A	4	8174
6,8	195	0,7	200,00	SW030/063	63D	4	4967
6,1	201	1,2	204,00	HA31+SW063	63D/71A	4	6270
6,1	214	1,1	218,18	HA31+SW063	63D/71A	4	6270
6,1	247	1,1	236,25	HA31+SW063	63D/71A	4	6270
6,1	228	1,5	237,50	HA31+SW075	63D/71A	4	7380
6,1	224	1,7	218,18	HA31+SW075	63D/71A	4	7380
6,1	244	2,1	237,50	HA31+SW090	63D/71A	4	8180
6,1	236	1,9	218,18	HA31+SW090	63D/71A	4	8180
6,1	222	1,2	142,50	HA31+SW063	71B	6	6270
6,1	281	0,9	157,50	HA31+SW063	71B	6	6270
6,1	234	1,7	154,67	HA31+SW075	71B	6	7380
6,1	232	1,5	142,50	HA31+SW075	71B	6	7380
6,1	266	1,4	163,64	HA31+SW075	71B	6	7380
6,1	226	2,3	147,22	HA31+SW090	71B	6	8180
6,1	241	2,1	158,82	HA31+SW090	71B	6	8180
5,5	252	1,5	250,00	SW040/075	63D/71A	4	7380
5,5	263	2,2	250,00	SW040/090	63D/71A	4	8180
5,5	269	2,1	250,00	SW050/090	71A	4	8180
5,5	280	3,7	250,00	SW050/105	71A	4	10320
5,4	227	0,7	250,00	SW030/063	63D	4	4967
5,1	260	2,0	255,00	HA31+SW090	63D/71A	4	8180
5,1	241	1,0	168,57	HA31+SW063	71B	6	6270
5,1	238	1,4	176,67	HA31+SW075	71B	6	7380
5,1	253	2,0	167,86	HA31+SW090	71B	6	8180
4,9	247	0,9	272,73	HA31+SW063	63D/71A	4	6270
4,9	258	1,4	272,73	HA31+SW075	63D/71A	4	7380
4,9	277	1,9	272,73	HA31+SW090	63D/71A	4	8180
4,9	294	0,9	189,00	HA31+SW063	71B	6	6270
4,8	269	1,3	193,33	HA31+SW075	71B	6	7380
4,8	289	1,8	193,33	HA31+SW090	71B	6	8180
4,6	280	1,6	300,00	SW040/075	63D/71A	4	7380
4,6	293	2,4	300,00	SW040/090	63D/71A	4	8180
4,6	300	2,3	300,00	SW050/090	71A	4	8180
4,6	300	3,7	300,00	SW050/105	71A	4	10320

## 0,25 kW

n2 [rpm]	M2 [Nm]	fs	i	Gear reducer	Motor		Fr2 [N]
					Size	Pole	
4,5	284	1,7	201,43	HA31+SW090	71B	6	8180
4,5	239	1,0	300,00	SW030/063	63D	4	6270
4,4	291	0,9	204,00	HA31+SW063	71B	6	6270
4,4	291	1,6	306,00	HA31+SW090	63D/71A	4	8180
4,3	302	0,8	315,00	HA31+SW063	63D/71A	4	6270
4,3	319	1,2	315,00	HA31+SW075	63D/71A	4	7380
4,1	311	0,8	218,18	HA31+SW063	71B	6	6270
4,1	327	1,2	218,18	HA31+SW075	71B	6	7380
4,1	344	1,4	218,18	HA31+SW090	71B	6	8180
4,1	310	1,6	327,27	HA31+SW090	63D/71A	4	8180
3,8	367	0,7	236,25	HA31+SW063	71B	6	6270
3,8	326	1,1	237,50	HA31+SW075	71B	6	7380
3,8	350	1,5	237,50	HA31+SW090	71B	6	8180
3,6	330	1,3	380,00	HA31+SW090	63D/71A	4	8180
3,5	377	1,5	255,00	HA31+SW090	71B	6	8180
3,5	365	1,0	393,75	HA31+SW075	63D/71A	4	7380
3,5	344	1,2	400,00	SW040/075	63D/71A	4	7380
3,5	362	1,7	400,00	SW040/090	63D/71A	4	8180
3,5	371	1,7	400,00	SW050/090	71A	4	8180
3,5	389	2,7	400,00	SW050/105	71A	4	10320
3,4	310	0,8	400,00	SW030/063	63D	4	6270
3,3	375	1,0	272,73	HA31+SW075	71B	6	7380
3,3	403	1,4	272,73	HA31+SW090	71B	6	8180
3,3	352	1,2	408,00	HA31+SW090	63D/71A	4	8180
3,1	374	1,2	436,36	HA31+SW090	63D/71A	4	8180
2,9	473	0,9	315,00	HA31+SW075	71B	6	7380
2,9	420	1,2	306,00	HA31+SW090	71B	6	8180
2,9	414	0,8	472,50	HA31+SW075	63D/71A	4	7380
2,9	438	1,1	472,50	HA31+SW090	63D/71A	4	8180
2,8	450	1,1	327,27	HA31+SW090	71B	6	8180
2,8	394	0,9	500,00	SW040/075	63D/71A	4	7380
2,8	423	1,3	500,00	SW040/090	63D/71A	4	8180
2,8	495	1,2	500,00	SW050/090	71A	4	8180
2,8	516	2,0	500,00	SW050/105	71A	4	10320
2,7	398	1,0	510,00	HA31+SW090	63D/71A	4	8180
2,5	422	0,9	545,45	HA31+SW090	63D/71A	4	8180
2,4	474	1,0	380,00	HA31+SW090	71B	6	8180
2,3	521	0,9	600,00	SW040/075	63D/71A	4	7380
2,3	546	1,3	600,00	SW040/090	63D/71A	4	8180
2,3	552	1,3	600,00	SW050/090	71A	4	8180
2,3	552	2,0	600,00	SW050/105	71A	4	10320
2,2	508	0,9	408,00	HA31+SW090	71B	6	8180

## 0,25 kW

n2 [rpm]	M2 [Nm]	fs	i	Gear reducer	Motor		Fr2 [N]
					Size	Pole	
2,1	530	0,8	630,00	HA31+SW090	63D/71A	4	8180
2,1	544	0,8	436,36	HA31+SW090	71B	6	8180
1,9	650	0,8	472,50	HA31+SW090	71B	6	8180
1,8	627	0,7	750,00	SW040/075	63D/71A	4	7380
1,8	656	1,1	750,00	SW040/090	63D/71A	4	8180
1,8	665	1,1	750,00	SW050/090	71A	4	8180
1,8	665	1,7	750,00	SW050/105	71A	4	10320
1,8	571	0,7	510,00	HA31+SW090	71B	6	8180
1,8	581	0,7	787,50	HA31+SW090	71A	4	8180
1,5	735	1,0	900,00	SW040/090	63D/71A	4	8180
1,5	756	0,9	900,00	SW050/090	71A	4	8180
1,5	756	1,5	900,00	SW050/105	71A	4	10320
1,2	912	0,8	1200,00	SW040/090	63D/71A	4	8180
1,2	939	0,8	1200,00	SW050/090	63D/71A	4	8180
1,2	939	1,2	1200,00	SW050/105	63D/71A	4	10320
0,9	1105	1,0	1500,00	SW050/105	63D/71A	4	10320
0,8	1243	0,9	1800,00	SW050/105	63D/71A	4	10320

## 0,37 kW

n2 [rpm]	M2 [Nm]	fs	i	Gear reducer	Motor		Fr2 [N]
					Size	Pole	
558,0	6	2,1	5,00	SW030	63C	2	474
372,0	8	1,6	7,50	SW030	63C	2	542
372,0	8	3,3	7,50	SW040	63C	2	1044
280,0	11	3,2	5,00	SW040	71B	4	1149
279,0	11	1,2	10,00	SW030	63C	2	597
279,0	11	2,6	10,00	SW040	63C	2	1149
186,7	17	2,5	7,50	SW040	71B	4	1315
186,0	16	0,8	15,00	SW030	63C	2	683
186,0	16	1,9	15,00	SW040	63C	2	1315
180,0	17	2,5	5,00	SW040	71C	6	1331
140,0	22	2,0	10,00	SW040	71B	4	1447
140,0	21	1,4	20,00	SW040	63C	2	1447
140,0	22	3,6	10,00	SW050	71B	4	1987
119,7	25	1,8	7,50	SW040	71C	6	1524
119,7	25	3,6	7,50	SW050	71C/80A	6	2091
112,0	25	1,1	25,00	SW040	63C	2	1559
93,3	32	1,4	15,00	SW040	71B	4	1657
93,3	32	2,5	15,00	SW050	71B	4	2274
93,0	29	1,2	30,00	SW040	63C	2	1657
90,0	32	1,4	10,00	SW040	71C	6	1677
90,0	33	2,8	10,00	SW050	71C/80A	6	2302

## 0,37 kW

n2 [rpm]	M2 [Nm]	fs	i	Gear reducer	Motor		Fr2 [N]
					Size	Pole	
70,0	39	1,1	20,00	SW040	71B	4	1824
70,0	37	0,8	40,00	SW040	63C	2	1824
70,0	40	1,9	20,00	SW050	71B	4	2503
70,0	37	1,6	40,00	SW050	63C	2	2503
63,0	46	3,7	15,00	SW063	80A	6	3444
60,3	47	1,1	15,00	SW040	71C	6	1920
60,3	47	1,9	15,00	SW050	71C/80A	6	2635
58,8	50	2,0	23,82	HA31+SW063	71B	4	3485
56,0	44	1,2	50,00	SW050	63C	2	2696
55,8	48	0,8	25,00	SW040	71B	4	1964
55,8	48	1,4	25,00	SW050	71B	4	2696
47,7	59	2,1	29,44	HA31+SW063	71B	4	3740
47,0	51	1,0	60,00	SW050	63C	2	2865
47,0	59	2,8	20,00	SW063	80A	6	3791
46,7	54	0,9	30,00	SW040	71B	4	2087
46,7	55	1,6	30,00	SW050	71B	4	2865
45,0	60	0,8	20,00	SW040	71C	6	2113
45,0	61	1,3	20,00	SW050	71C/80A	6	2900
38,0	71	2,1	25,00	SW063	80A	6	4084
38,0	73	3,3	25,00	SW075	80A	6	4820
37,8	76	1,4	23,82	HA31+SW063	71C/80A	6	4049
36,5	76	1,7	38,67	HA31+SW063	71B	4	4095
35,8	72	1,0	25,00	SW050	71C/80A	6	3124
35,5	69	1,2	40,00	SW050	71B	4	3153
35,5	72	2,0	40,00	SW063	71B	4	4122
35,0	63	0,7	80,00	SW050	63C	2	3153
31,4	84	2,1	44,17	HA31+SW063	71B	4	4281
31,0	80	2,2	30,00	SW063	80A	6	4339
31,0	83	3,4	30,00	SW075	80A	6	5122
30,7	90	1,5	29,44	HA31+SW063	71C/80A	6	4345
29,7	81	1,1	30,00	SW050	71C/80A	6	3320
29,4	93	1,5	47,50	HA31+SW063	71B	4	4386
28,4	81	0,9	50,00	SW050	71B	4	3397
28,4	85	1,7	50,00	SW063	71B	4	4440
28,4	89	2,5	50,00	SW075	71B	4	5241
24,0	104	2,7	40,00	SW075	80A	6	5637
23,5	116	1,2	38,67	HA31+SW063	71C/80A	6	4758
23,3	107	1,8	58,89	HA31+SW063	71B	4	4712
23,3	91	0,8	60,00	SW050	71B	4	3610
23,3	96	1,4	60,00	SW063	71B	4	4719
23,3	100	2,1	60,00	SW075	71B	4	5569
22,5	101	0,9	40,00	SW050	71C	6	3654



## 0,37 kW

n2 [rpm]	M2 [Nm]	fs	i	Gear reducer	Motor		Fr2 [N]
					Size	Pole	
22,5	104	1,6	40,00	SW063	71C/80A	6	4776
20,5	127	1,5	44,17	HA31+SW063	71C/80A	6	4974
19,4	143	1,0	47,50	HA31+SW063	71C/80A	6	5096
19,3	131	1,5	71,25	HA31+SW063	71B	4	5021
19,0	130	3,3	50,00	SW090	80A	6	6719
18,4	121	1,3	50,00	SW063	71C/80A	6	5145
18,4	125	2,0	50,00	SW075	71C/80A	6	6073
18,3	138	1,6	77,33	HA31+SW063	71B	4	5160
18,3	141	1,7	77,33	HA31+SW075	71B	4	6090
17,2	150	1,3	81,82	HA31+SW063	71B	4	5258
17,2	117	1,0	80,00	SW063	71B	4	5193
17,2	123	1,6	80,00	SW075	71B	4	6130
16,2	142	1,5	88,33	HA31+SW063	71B	4	5394
16,2	149	1,9	83,93	HA31+SW075	71B	4	6259
16,0	147	2,6	60,00	SW090	80A	6	7140
15,3	161	1,4	58,89	HA31+SW063	71C/80A	6	5474
15,3	139	1,1	60,00	SW063	71C/80A	6	5467
15,3	146	1,7	60,00	SW075	71C/80A	6	6453
15,2	167	1,4	95,00	HA31+SW063	71B	4	5526
14,2	177	1,3	102,00	HA31+SW063	71B	4	5659
14,2	159	2,0	95,29	HA31+SW075	71B	4	6529
14,2	169	2,3	102,00	HA31+SW090	71B	4	7390
14,2	131	0,9	100,00	SW063	71B	4	5595
14,2	141	1,3	100,00	SW075	71B	4	6603
14,0	170	2,1	100,00	SW040/075	71B	4	5863
14,0	173	2,1	100,00	SW040/090	71B	4	6487
14,0	177	3,3	100,00	SW050/090	71B	4	6487
14,0	177	3,7	100,00	SW050/105	71B	4	8198
13,2	189	1,3	109,09	HA31+SW063	71B	4	5787
13,2	195	1,3	109,09	HA31+SW075	71B	4	6830
12,3	200	1,0	71,25	HA31+SW063	71C/80A	6	5833
12,2	181	1,3	116,00	HA31+SW063	71B	4	5907
12,2	183	1,8	117,78	HA31+SW075	71B	4	7007
12,2	192	2,1	117,78	HA31+SW090	71B	4	7753
12,0	180	1,7	80,00	SW090	80A	6	7859
12,0	192	2,8	80,00	SW105	80A	6	9931
11,2	207	1,2	77,33	HA31+SW063	71C/80A	6	5995
11,2	231	0,9	81,82	HA31+SW063	71C	6	6108
11,2	214	1,2	77,33	HA31+SW075	71C/80A	6	7076
11,2	166	0,8	80,00	SW063	71C	6	6018
11,2	176	1,2	80,00	SW075	71C/80A	6	7103
11,2	213	1,0	127,50	HA31+SW063	71B	4	6096

## 0,37 kW

n2 [rpm]	M2 [Nm]	fs	i	Gear reducer	Motor		Fr2 [N]
					Size	Pole	
11,2	202	2,3	127,50	HA31+SW090	71B	4	7961
10,2	211	1,2	88,33	HA31+SW063	71C/80A	6	6266
10,2	224	1,3	83,93	HA31+SW075	71C/80A	6	7271
10,1	218	1,1	142,50	HA31+SW063	71B	4	6270
10,1	206	1,7	134,29	HA31+SW075	71B	4	7320
10,1	229	1,5	142,50	HA31+SW075	71B	4	7380
10,1	216	1,9	134,29	HA31+SW090	71B	4	8100
9,3	242	1,7	150,00	SW040/075	71B	4	6712
9,3	254	1,4	150,00	SW040/090	71B	4	6487
9,3	253	2,6	150,00	SW050/090	71B	4	7426
9,3	256	3,7	150,00	SW050/105	71B	4	9384
9,2	253	1,0	95,00	HA31+SW063	71C/80A	6	6270
9,2	272	0,9	102,00	HA31+SW063	71C	6	6270
9,2	238	1,4	95,29	HA31+SW075	71C/80A	6	7380
9,2	250	1,6	102,00	HA31+SW090	71C/80A	6	8180
9,2	200	1,0	100,00	SW075	71C/80A	6	7380
9,1	270	0,9	157,50	HA31+SW063	71B	4	6270
9,1	234	1,6	154,67	HA31+SW075	71B	4	7380
9,1	229	2,1	147,22	HA31+SW090	71B	4	8180
9,1	244	2,0	158,82	HA31+SW090	71B	4	8180
9,0	207	1,4	100,00	SW090	80A	6	8180
9,0	222	2,2	100,00	SW105	80A	6	10320
8,2	272	1,0	116,00	HA31+SW063	71C/80A	6	6270
8,2	290	0,9	109,09	HA31+SW063	71C	6	6270
8,2	299	0,9	109,09	HA31+SW075	71C	6	7380
8,1	242	1,0	168,57	HA31+SW063	71B	4	6270
8,1	244	1,2	176,67	HA31+SW075	71B	4	7380
8,1	260	1,3	163,64	HA31+SW075	71B	4	7380
8,1	256	1,9	167,86	HA31+SW090	71B	4	8180
7,2	273	1,4	117,78	HA31+SW075	71C/80A	6	7380
7,2	308	1,3	134,29	HA31+SW075	71C/80A	6	7380
7,2	296	1,6	127,50	HA31+SW090	71C/80A	6	8180
7,2	286	1,5	117,78	HA31+SW090	71C/80A	6	8180
7,2	323	1,3	134,29	HA31+SW090	71C/80A	6	8180
7,1	287	0,8	204,00	HA31+SW063	71B	4	6270
7,1	284	0,9	189,00	HA31+SW063	71B	4	6270
7,1	271	1,2	193,33	HA31+SW075	71B	4	7380
7,1	288	1,6	201,43	HA31+SW090	71B	4	8180
7,1	290	1,7	193,33	HA31+SW090	71B	4	8180
7,0	305	1,4	200,00	SW040/075	71B	4	7380
7,0	322	1,1	200,00	SW040/090	71B	4	6487
7,0	324	1,9	200,00	SW050/090	71B	4	8174

## 0,37 kW

n2 [rpm]	M2 [Nm]	fs	i	Gear reducer	Motor		Fr2 [N]
					Size	Pole	
7,0	333	2,9	200,00	SW050/105	71B	4	10320
6,1	331	0,8	142,50	HA31+SW063	71C/80A	6	6270
6,1	351	1,1	154,67	HA31+SW075	71C/80A	6	7380
6,1	347	1,0	142,50	HA31+SW075	71C/80A	6	7380
6,1	337	1,5	147,22	HA31+SW090	71C/80A	6	8180
6,1	361	1,4	158,82	HA31+SW090	71C/80A	6	8180
6,1	306	0,8	218,18	HA31+SW063	71B	4	6270
6,1	353	0,8	236,25	HA31+SW063	71B	4	6270
6,1	325	1,1	237,50	HA31+SW075	71B	4	7380
6,1	320	1,2	218,18	HA31+SW075	71B	4	7380
6,1	348	1,5	237,50	HA31+SW090	71B	4	8180
6,1	336	1,3	218,18	HA31+SW090	71B	4	8180
6,0	346	0,7	168,57	HA31+SW063	80A	6	6270
5,6	365	1,0	250,00	SW040/075	71B	4	7380
5,6	380	1,5	250,00	SW040/090	71B	4	8180
5,6	389	1,4	250,00	SW050/090	71B	4	8180
5,6	406	2,5	250,00	SW050/105	71B	4	10320
5,1	357	0,9	176,67	HA31+SW075	71C/80A	6	7380
5,1	399	0,9	163,64	HA31+SW075	71C	6	7380
5,1	379	1,3	167,86	HA31+SW090	71C/80A	6	8180
5,1	368	1,0	272,73	HA31+SW075	71B	4	7380
5,1	372	1,4	255,00	HA31+SW090	71B	4	8180
5,1	395	1,3	272,73	HA31+SW090	71B	4	8180
4,7	403	0,9	193,33	HA31+SW075	71C/80A	6	7380
4,7	432	1,2	193,33	HA31+SW090	71C/80A	6	8180
4,7	406	1,1	300,00	SW040/075	71B	4	7380
4,7	425	1,6	300,00	SW040/090	71B	4	8180
4,7	435	1,6	300,00	SW050/090	71B	4	8180
4,7	435	2,5	300,00	SW050/105	71B	4	10320
4,6	416	1,2	306,00	HA31+SW090	71B	4	8180
4,5	424	1,1	201,43	HA31+SW090	71C/80A	6	8180
4,5	455	0,9	315,00	HA31+SW075	71B	4	7380
4,3	442	1,1	327,27	HA31+SW090	71B	4	8180
4,1	490	0,8	218,18	HA31+SW075	71C	6	7380
4,1	515	0,9	218,18	HA31+SW090	71C	6	8180
3,8	489	0,7	237,50	HA31+SW075	71C/80A	6	7380
3,8	525	1,0	237,50	HA31+SW090	71C/80A	6	8180
3,7	470	0,9	380,00	HA31+SW090	71B	4	8180
3,6	563	1,0	255,00	HA31+SW090	71C	6	8180
3,5	499	0,8	400,00	SW040/075	71B	4	7380
3,5	524	1,1	400,00	SW040/090	71B	4	8180
3,5	537	1,1	400,00	SW050/090	71B	4	8180

## 0,37 kW

n2 [rpm]	M2 [Nm]	fs	i	Gear reducer	Size	Motor Pole	Fr2 [N]
3,5	563	1,8	400,00	SW050/105	71B	4	10320
3,4	502	0,9	408,00	HA31+SW090	71B	4	8180
3,3	602	0,9	272,73	HA31+SW090	71C	6	8180
3,2	533	0,8	436,36	HA31+SW090	71B	4	8180
3,0	630	0,8	306,00	HA31+SW090	71C	6	8180
2,9	625	0,8	472,50	HA31+SW090	71B	4	8180
2,8	613	0,9	500,00	SW040/090	71B	4	8180
2,8	717	0,8	500,00	SW050/090	71B	4	8180
2,8	746	1,3	500,00	SW050/105	71B	4	10320
2,8	673	0,7	327,27	HA31+SW090	71C	6	8180
2,3	791	0,9	600,00	SW040/090	71B	4	8180
2,3	800	0,9	600,00	SW050/090	71B	4	8180
2,3	800	1,4	600,00	SW050/105	71B	4	10320
1,9	950	0,7	750,00	SW040/090	71B	4	8180
1,9	963	0,7	750,00	SW050/090	71B	4	8180
1,9	963	1,1	750,00	SW050/105	71B	4	10320
1,6	1095	1,0	900,00	SW050/105	71B	4	10320
1,2	1360	0,8	1200,00	SW050/105	71B	4	10320

## 0,55 kW

n2 [rpm]	M2 [Nm]	fs	i	Gear reducer	Size	Motor Pole	Fr2 [N]
566,0	8	2,9	5,00	SW040	71B	2	912
377,7	12	2,2	7,50	SW040	71B	2	1044
283,0	16	1,8	10,00	SW040	71B	2	1149
283,0	17	3,2	10,00	SW050	71B	2	1577
280,0	17	2,1	5,00	SW040	71C	4	1149
280,0	17	4,1	5,00	SW050	71C	4	1577
189,7	25	3,1	7,50	SW050	71C/80A	4	1805
188,3	24	1,3	15,00	SW040	71B	2	1315
188,3	24	2,4	15,00	SW050	71B	2	1805
188,0	25	3,3	5,00	SW050	80B	6	1827
187,0	24	1,7	7,50	SW040	71C	4	1315
142,0	31	0,9	20,00	SW040	71B	2	1447
142,0	31	1,7	20,00	SW050	71B	2	1987
142,0	33	2,4	10,00	SW050	71C/80A	4	1987
140,0	32	1,4	10,00	SW040	71C	4	1447
125,3	36	2,5	7,50	SW050	80B	6	2091
112,8	37	0,7	25,00	SW040	71B	2	1559
112,8	38	1,3	25,00	SW050	71B	2	2140
94,7	43	0,8	30,00	SW040	71B	2	1657
94,7	43	1,5	30,00	SW050	71B	2	2274

## 0,55 kW

n2 [rpm]	M2 [Nm]	fs	i	Gear reducer	Motor		Fr2 [N]
					Size	Pole	
94,3	46	3,2	15,00	SW063	80A	4	2973
94,0	47	1,9	10,00	SW050	80B	6	2302
94,0	47	3,2	10,00	SW063	80B	6	3009
93,0	47	0,9	15,00	SW040	71C	4	1657
93,0	47	1,7	15,00	SW050	71C/80A	4	2274
71,0	61	2,4	20,00	SW063	80A	4	3272
71,0	61	3,9	20,00	SW075	80A	4	3862
70,5	60	0,7	20,00	SW040	71C	4	1824
70,5	60	1,3	20,00	SW050	71C/80A	4	2503
70,5	55	1,1	40,00	SW050	71B	2	2503
70,5	57	2,0	40,00	SW063	71B	2	3272
62,7	67	1,4	15,00	SW050	80B	6	2635
62,7	68	2,5	15,00	SW063	80B	6	3444
59,3	74	1,3	23,82	HA31+SW063	71C/80A	4	3493
56,8	73	1,8	25,00	SW063	80A	4	3524
56,8	75	2,8	25,00	SW075	80A	4	4160
56,4	65	0,8	50,00	SW050	71B	2	2696
56,4	67	1,6	50,00	SW063	71B	2	3524
56,4	70	2,4	50,00	SW075	71B	2	4160
56,2	72	1,0	25,00	SW050	71C/80A	4	2696
48,0	88	1,4	29,44	HA31+SW063	71C/80A	4	3749
47,7	83	1,9	30,00	SW063	80A	4	3745
47,7	86	2,9	30,00	SW075	80A	4	4421
47,5	86	1,0	20,00	SW050	80B	6	2900
47,5	87	1,9	20,00	SW063	80B	6	3791
47,5	89	3,0	20,00	SW075	80B	6	4474
47,3	76	1,3	60,00	SW063	71B	2	3745
47,3	80	2,0	60,00	SW075	71B	2	4421
47,0	82	1,0	30,00	SW050	71C/80A	4	2865
39,4	108	1,0	23,82	HA31+SW063	80B	6	3975
37,4	103	0,7	25,00	SW050	80B	6	3124
37,4	106	1,4	25,00	SW063	80B	6	4084
37,4	109	2,2	25,00	SW075	80B	6	4820
35,8	114	1,1	38,67	HA31+SW063	71C/80A	4	4105
35,5	108	2,2	40,00	SW075	80A	4	4865
35,5	112	3,5	40,00	SW090	80A	4	5383
35,2	95	0,9	80,00	SW063	71B	2	4122
35,2	99	1,4	80,00	SW075	71B	2	4865
34,7	102	0,8	40,00	SW050	71C	4	3153
34,7	107	1,4	40,00	SW063	71C/80A	4	4122
32,3	128	1,1	29,44	HA31+SW063	80B	6	4266
31,7	125	1,4	44,17	HA31+SW063	71C/80A	4	4291

## 0,55 kW

n2 [rpm]	M2 [Nm]	fs	i	Gear reducer	Motor		Fr2 [N]
					Size	Pole	
31,3	116	0,8	30,00	SW050	80B	6	3320
31,3	119	1,5	30,00	SW063	80B	6	4339
31,3	124	2,3	30,00	SW075	80B	6	5122
29,6	138	1,0	47,50	HA31+SW063	71C/80A	4	4397
28,4	135	2,7	50,00	SW090	80A	4	5799
28,2	109	0,7	100,00	SW063	71B	2	4440
28,2	115	1,1	100,00	SW075	71B	2	5241
27,6	125	1,1	50,00	SW063	71C/80A	4	4440
27,6	131	1,7	50,00	SW075	71C/80A	4	5241
24,3	166	0,8	38,67	HA31+SW063	80B	6	4671
23,5	160	1,2	58,89	HA31+SW063	71C/80A	4	4723
23,5	142	0,9	60,00	SW063	71C/80A	4	4719
23,5	149	1,4	60,00	SW075	71C/80A	4	5569
23,3	156	2,2	60,00	SW090	80A	4	6163
23,2	147	1,1	40,00	SW063	80B	6	4776
23,2	154	1,8	40,00	SW075	80B	6	5637
23,2	161	2,8	40,00	SW090	80B	6	6238
21,2	180	1,1	44,17	HA31+SW063	80B	6	4883
20,2	204	0,7	47,50	HA31+SW063	80B	6	5003
19,4	195	1,0	71,25	HA31+SW063	71C/80A	4	5033
19,2	173	0,9	50,00	SW063	80B	6	5145
19,2	179	1,4	50,00	SW075	80B	6	6073
19,2	193	2,2	50,00	SW090	80B	6	6719
18,4	205	1,1	77,33	HA31+SW063	71C/80A	4	5172
18,4	210	1,1	77,33	HA31+SW075	71C/80A	4	6105
18,3	189	1,5	80,00	SW090	80A	4	6783
18,3	201	2,4	80,00	SW105	80A	4	8571
17,4	222	0,9	81,82	HA31+SW063	71C	4	5270
17,4	183	1,0	80,00	SW075	71C/80A	4	6130
16,4	210	1,0	88,33	HA31+SW063	71C/80A	4	5407
16,4	222	1,2	83,93	HA31+SW075	71C/80A	4	6274
16,2	230	1,0	58,89	HA31+SW063	80B	6	5374
16,2	198	0,8	60,00	SW063	80B	6	5467
16,2	208	1,2	60,00	SW075	80B	6	6453
16,2	218	1,7	60,00	SW090	80B	6	7140
14,3	248	0,9	95,00	HA31+SW063	71C/80A	4	5540
14,3	236	1,3	95,29	HA31+SW075	71C/80A	4	6545
14,3	210	0,8	100,00	SW075	71C/80A	4	6603
14,2	264	2,2	100,00	SW050/090	71C/80A	4	6487
14,2	264	2,4	100,00	SW050/105	71C/80A	4	8198
14,2	222	1,2	100,00	SW090	80A	4	7306
14,2	237	1,9	100,00	SW105	80A	4	9232

## 0,55 kW

n2 [rpm]	M2 [Nm]	fs	i	Gear reducer	Motor		Fr2 [N]
					Size	Pole	
14,0	250	1,4	100,00	SW040/075	71C	4	5863
14,0	255	1,4	100,00	SW040/090	71C	4	6487
13,3	264	0,9	102,00	HA31+SW063	71C	4	5672
13,3	282	0,8	109,09	HA31+SW063	71C	4	5801
13,3	290	0,9	109,09	HA31+SW075	71C	4	6847
13,3	251	1,6	102,00	HA31+SW090	71C/80A	4	7408
13,1	286	0,7	71,25	HA31+SW063	80B	6	5727
12,3	269	0,9	116,00	HA31+SW063	71C/80A	4	5921
12,3	273	1,2	117,78	HA31+SW075	71C/80A	4	7024
12,3	286	1,4	117,78	HA31+SW090	71C/80A	4	7772
12,1	296	0,8	77,33	HA31+SW063	80B	6	5885
12,1	304	0,8	77,33	HA31+SW075	80B	6	6947
12,1	250	0,9	80,00	SW075	80B	6	7103
12,1	268	1,2	80,00	SW090	80B	6	7859
12,1	286	1,9	80,00	SW105	80B	6	9931
11,2	299	1,6	127,50	HA31+SW090	71C/80A	4	7980
11,1	301	0,8	88,33	HA31+SW063	80B	6	6152
11,1	319	0,9	83,93	HA31+SW075	80B	6	7139
10,2	325	0,8	142,50	HA31+SW063	71C/80A	4	6270
10,2	306	1,1	134,29	HA31+SW075	71C/80A	4	7338
10,2	341	1,0	142,50	HA31+SW075	71C/80A	4	7380
10,2	321	1,2	134,29	HA31+SW090	71C/80A	4	8119
10,1	337	1,0	95,29	HA31+SW075	80B	6	7380
9,5	377	1,7	150,00	SW050/090	71C/80A	4	7426
9,5	382	2,4	150,00	SW050/105	71C/80A	4	9384
9,3	356	1,2	150,00	SW040/075	71C	4	6712
9,3	375	0,9	150,00	SW040/090	71C	4	6487
9,2	347	1,0	154,67	HA31+SW075	71C/80A	4	7380
9,2	341	1,4	147,22	HA31+SW090	71C/80A	4	8180
9,2	363	1,3	158,82	HA31+SW090	71C/80A	4	8180
9,1	357	1,2	102,00	HA31+SW090	80B	6	8180
9,1	308	0,9	100,00	SW090	80B	6	8180
9,1	329	1,5	100,00	SW105	80B	6	10320
8,2	363	0,8	176,67	HA31+SW075	71C/80A	4	7380
8,2	387	0,9	163,64	HA31+SW075	71C	4	7380
8,2	381	1,2	167,86	HA31+SW090	71C/80A	4	8180
8,1	388	1,0	117,78	HA31+SW075	80B	6	7380
8,1	407	1,1	117,78	HA31+SW090	80B	6	8180
7,2	403	0,8	193,33	HA31+SW075	71C/80A	4	7380
7,2	428	1,0	201,43	HA31+SW090	71C/80A	4	8180
7,2	431	1,1	193,33	HA31+SW090	71C/80A	4	8180
7,1	483	1,2	200,00	SW050/090	71C/80A	4	8174

## 0,55 kW

n2 [rpm]	M2 [Nm]	fs	i	Gear reducer	Motor		Fr2 [N]
					Size	Pole	
7,1	496	2,0	200,00	SW050/105	71C/80A	4	10320
7,1	437	0,9	134,29	HA31+SW075	80B	6	7380
7,1	495	0,7	142,50	HA31+SW075	80B	6	7380
7,1	421	1,2	127,50	HA31+SW090	80B	6	8180
7,1	459	0,9	134,29	HA31+SW090	80B	6	8180
7,0	449	0,9	200,00	SW040/075	71C	4	7380
7,0	476	0,7	200,00	SW040/090	71C	4	6487
6,1	483	0,7	237,50	HA31+SW075	71C/80A	4	7380
6,1	476	0,8	218,18	HA31+SW075	71C	4	7380
6,1	518	1,0	237,50	HA31+SW090	71C/80A	4	8180
6,1	500	0,9	218,18	HA31+SW090	71C	4	8180
6,1	500	0,8	154,67	HA31+SW075	80B	6	7380
6,1	480	1,1	147,22	HA31+SW090	80B	6	8180
6,1	514	1,0	158,82	HA31+SW090	80B	6	8180
6,1	540	0,9	167,86	HA31+SW090	80B	6	8180
5,7	580	1,0	250,00	SW050/090	71C/80A	4	8180
5,7	603	1,7	250,00	SW050/105	71C/80A	4	10320
5,6	562	1,0	250,00	SW040/090	71C	4	8180
5,1	552	0,9	255,00	HA31+SW090	71C	4	8180
5,1	587	0,9	272,73	HA31+SW090	71C	4	8180
4,9	614	0,8	193,33	HA31+SW090	80B	6	8180
4,7	647	1,1	300,00	SW050/090	71C/80A	4	8180
4,7	647	1,7	300,00	SW050/105	71C/80A	4	10320
4,7	599	0,7	300,00	SW040/075	71C	4	7380
4,7	627	1,1	300,00	SW040/090	71C	4	8180
4,6	605	0,8	201,43	HA31+SW090	80B	6	8180
4,6	617	0,8	306,00	HA31+SW090	71C	4	8180
4,3	657	0,7	327,27	HA31+SW090	71C	4	8180
3,9	747	0,7	237,50	HA31+SW090	80B	6	8180
3,5	798	0,8	400,00	SW050/090	71C/80A	4	8180
3,5	837	1,2	400,00	SW050/105	71C/80A	4	10320
3,5	774	0,8	400,00	SW040/090	71C	4	8180
2,8	1110	0,9	500,00	SW050/105	71C/80A	4	10320
2,4	1190	0,9	600,00	SW050/105	71C/80A	4	10320
1,9	1432	0,8	750,00	SW050/105	71C/80A	4	10320

## 0,75 kW

n2 [rpm]	M2 [Nm]	fs	i	Gear reducer	Motor		Fr2 [N]
					Size	Pole	
572,0	12	4,0	5,00	SW050	80A	2	1251
381,0	17	3,1	7,50	SW050	80A	2	1433
288,0	22	3,1	5,00	SW050	80B	4	1577



## 0,75 kW

n <sub>2</sub> [rpm]	M <sub>2</sub> [Nm]	f <sub>s</sub>	i	Gear reducer	Motor		Fr <sub>2</sub> [N]
					Size	Pole	
286,0	23	2,4	10,00	SW050	80A	2	1577
192,3	33	2,4	7,50	SW050	80B	4	1805
192,3	33	3,8	7,50	SW063	80B	4	2359
191,0	33	3,3	15,00	SW063	80A	2	2359
190,3	33	1,8	15,00	SW050	80A	2	1805
144,0	44	1,9	10,00	SW050	80B	4	1987
144,0	44	3,1	10,00	SW063	80B	4	2597
143,5	43	4,0	20,00	SW075	80A	2	3065
143,0	42	1,3	20,00	SW050	80A	2	1987
143,0	43	2,4	20,00	SW063	80A	2	2597
125,0	50	3,0	7,50	SW063	90S	6	2734
114,0	51	1,0	25,00	SW050	80A	2	2140
114,0	52	1,8	25,00	SW063	80A	2	2797
114,0	53	3,1	25,00	SW075	80A	2	3302
96,0	63	2,4	15,00	SW063	80B	4	2973
95,7	60	2,0	30,00	SW063	80A	2	2973
95,7	62	1,3	15,00	SW050	80B	4	2274
95,0	58	1,1	30,00	SW050	80A	2	2274
95,0	61	3,0	30,00	SW075	80A	2	3509
94,0	65	2,4	10,00	SW063	90S	6	3009
94,0	66	3,5	10,00	SW075	90S	6	3551
72,0	80	1,0	20,00	SW050	80B	4	2503
72,0	82	1,8	20,00	SW063	80B	4	3272
72,0	83	2,9	20,00	SW075	80B	4	3862
71,5	76	1,5	40,00	SW063	80A	2	3272
71,2	79	2,3	40,00	SW075	80A	2	3862
71,2	81	3,5	40,00	SW090	80A	2	4273
63,0	94	1,8	15,00	SW063	90S	6	3444
63,0	95	2,8	15,00	SW075	90S	6	4065
60,4	98	1,0	23,82	HA31+SW063	80B	4	3444
58,0	96	0,7	25,00	SW050	80B	4	2696
57,6	101	2,2	25,00	SW075	80B	4	4160
57,4	94	1,7	50,00	SW075	80A	2	4160
57,4	96	2,7	50,00	SW090	80A	2	4603
57,4	98	1,4	25,00	SW063	80B	4	3524
57,0	90	1,1	50,00	SW063	80A	2	3524
49,3	116	1,1	29,44	HA31+SW063	80B	4	3696
48,3	109	0,8	30,00	SW050	80B	4	2865
48,3	112	1,4	30,00	SW063	80B	4	3745
48,3	115	2,1	30,00	SW075	80B	4	4421
48,0	113	2,2	60,00	SW090	80A	2	4891
47,8	104	0,9	60,00	SW063	80A	2	3745

## 0,75 kW

n2 [rpm]	M2 [Nm]	fs	i	Gear reducer	Size	Motor Pole	Fr2 [N]
47,3	108	1,5	60,00	SW075	80A	2	4421
47,0	119	1,4	20,00	SW063	90S	6	3791
47,0	122	2,2	20,00	SW075	90S	6	4474
47,0	125	3,5	20,00	SW090	90S	6	4951
38,0	145	1,0	25,00	SW063	90S	6	4084
38,0	149	1,6	25,00	SW075	90S	6	4820
37,8	153	2,7	25,00	SW090	90S	6	5333
37,0	151	0,9	38,67	HA31+SW063	80B	4	4076
36,3	141	1,0	40,00	SW063	80B	4	4122
36,0	145	1,7	40,00	SW075	80B	4	4865
36,0	152	2,6	40,00	SW090	80B	4	5383
35,6	135	1,0	80,00	SW075	80A	2	4865
35,6	141	1,6	80,00	SW090	80A	2	5383
35,6	148	2,5	80,00	SW105	80A	2	6803
33,0	166	1,1	44,17	HA31+SW063	80B	4	4221
31,7	162	1,1	30,00	SW063	90S	6	4339
31,7	169	1,6	30,00	SW075	90S	6	5122
31,7	174	2,8	30,00	SW090	90S	6	5667
31,7	176	4,0	30,00	SW105	90S	6	7161
30,2	184	0,7	47,50	HA31+SW063	80B	4	4334
29,0	167	0,9	50,00	SW063	80B	4	4440
29,0	182	2,1	50,00	SW090	80B	4	5799
28,8	174	1,3	50,00	SW075	80B	4	5241
28,5	155	0,8	100,00	SW075	80A	2	5241
28,5	165	1,2	100,00	SW090	80A	2	5799
28,2	176	2,0	100,00	SW105	80A	2	7328
24,0	212	0,9	58,89	HA31+SW063	80B	4	4645
24,0	188	0,7	60,00	SW063	80B	4	4719
23,7	197	1,1	60,00	SW075	80B	4	5569
23,7	209	1,6	60,00	SW090	80B	4	6163
23,5	210	1,3	40,00	SW075	90S	6	5637
23,5	219	2,0	40,00	SW090	90S	6	6238
23,5	229	3,1	40,00	SW105	90S	6	7882
20,1	259	0,7	71,25	HA31+SW063	80B	4	4962
18,5	271	0,8	77,33	HA31+SW063	80B	4	5135
18,5	243	0,8	80,00	SW075	80B	4	6130
18,4	263	1,6	50,00	SW090	90S	6	6719
18,4	274	2,5	50,00	SW105	90S	6	8491
18,1	279	0,9	77,33	HA31+SW075	80B	4	6018
18,0	255	1,1	80,00	SW090	80B	4	6783
18,0	271	1,8	80,00	SW105	80B	4	8571
17,0	294	1,0	83,93	HA31+SW075	80B	4	6171

## 0,75 kW

n2 [rpm]	M2 [Nm]	fs	i	Gear reducer	Size	Motor Pole	Fr2 [N]
16,0	280	0,8	88,33	HA31+SW063	80B	4	5318
15,4	313	1,0	95,29	HA31+SW075	80B	4	6498
15,3	298	1,3	60,00	SW090	90S	6	7140
15,3	315	2,0	60,00	SW105	90S	6	9023
15,0	328	0,7	95,00	HA31+SW063	80B	4	5448
14,4	365	1,6	100,00	SW050/090	80B	4	6487
14,4	365	1,8	100,00	SW050/105	80B	4	8198
14,1	299	0,9	100,00	SW090	80B	4	7306
14,1	319	1,4	100,00	SW105	80B	4	9232
14,0	333	1,2	102,00	HA31+SW090	80B	4	7286
12,3	362	0,9	117,78	HA31+SW075	80B	4	6974
12,3	391	1,4	80,00	SW105	90S	6	9931
12,1	378	1,1	117,78	HA31+SW090	80B	4	7662
11,3	398	1,2	127,50	HA31+SW090	80B	4	7923
11,1	406	0,9	134,29	HA31+SW075	80B	4	7234
11,1	425	1,0	134,29	HA31+SW090	80B	4	8004
10,3	451	0,7	142,50	HA31+SW075	80B	4	7380
10,3	451	1,1	147,22	HA31+SW090	80B	4	8180
9,6	521	1,3	150,00	SW050/090	80B	4	7426
9,6	527	1,8	150,00	SW050/105	80B	4	9384
9,3	461	0,8	154,67	HA31+SW075	80B	4	7380
9,1	482	1,0	158,82	HA31+SW090	80B	4	8180
9,0	505	1,0	167,86	HA31+SW090	80B	4	8180
9,0	450	1,1	100,00	SW105	90S	6	10320
7,2	572	0,9	193,33	HA31+SW090	80B	4	8180
7,2	668	0,9	200,00	SW050/090	80B	4	8174
7,2	685	1,4	200,00	SW050/105	80B	4	10320
7,0	567	0,8	201,43	HA31+SW090	80B	4	8180
6,2	686	0,7	237,50	HA31+SW090	80B	4	8180
5,8	801	0,7	250,00	SW050/090	80B	4	8180
5,8	835	1,2	250,00	SW050/105	80B	4	10320
4,8	895	0,8	300,00	SW050/090	80B	4	8180
4,8	895	1,2	300,00	SW050/105	80B	4	10320
3,6	1157	0,9	400,00	SW050/105	80B	4	10320

## 1,10 kW

n2 [rpm]	M2 [Nm]	fs	i	Gear reducer	Size	Motor Pole	Fr2 [N]
572,0	17	2,7	5,00	SW050	80B	2	1251
381,0	25	2,1	7,50	SW050	80B	2	1433
381,0	25	3,7	7,50	SW063	80B	2	1873
286,0	33	1,7	10,00	SW050	80B	2	1577

## 1,10 kW

n <sub>2</sub> [rpm]	M <sub>2</sub> [Nm]	f <sub>s</sub>	i	Gear reducer	Motor		Fr <sub>2</sub> [N]
					Size	Pole	
286,0	33	3,0	10,00	SW063	80B	2	2061
191,0	49	2,6	7,50	SW063	90S	4	2359
191,0	48	2,3	15,00	SW063	80B	2	2359
191,0	49	3,8	7,50	SW075	90S	4	2785
190,3	48	1,2	15,00	SW050	80B	2	1805
143,5	61	0,9	20,00	SW050	80B	2	1987
143,0	64	2,1	10,00	SW063	90S	4	2597
143,0	63	1,7	20,00	SW063	80B	2	2597
143,0	65	3,1	10,00	SW075	90S	4	3065
143,0	64	2,7	20,00	SW075	80B	2	3065
127,0	73	2,9	7,50	SW075	100LR	6	3227
114,8	76	1,2	25,00	SW063	80B	2	2797
114,8	77	2,0	25,00	SW075	80B	2	3302
95,7	87	1,4	30,00	SW063	80B	2	2973
95,7	89	2,1	30,00	SW075	80B	2	3509
95,0	95	2,4	10,00	SW075	100LR	6	3551
95,0	95	2,4	15,00	SW075	90S	4	3509
95,0	85	0,7	30,00	SW050	80B	2	2274
95,0	93	1,6	15,00	SW063	90S	4	2973
72,0	112	1,0	40,00	SW063	80B	2	3272
72,0	115	1,6	40,00	SW075	80B	2	3862
72,0	118	2,3	40,00	SW090	80B	2	4273
71,5	120	1,2	20,00	SW063	90S	4	3272
71,5	122	1,9	20,00	SW075	90S	4	3862
71,5	125	3,2	20,00	SW090	90S	4	4273
63,0	138	1,9	15,00	SW075	100LR	6	4065
63,0	141	3,3	15,00	SW090	100LR	6	4498
57,6	133	0,8	50,00	SW063	80B	2	3524
57,6	142	1,9	50,00	SW090	80B	2	4603
57,4	138	1,2	50,00	SW075	80B	2	4160
57,2	153	2,5	25,00	SW090	90S	4	4603
57,0	145	0,9	25,00	SW063	90S	4	3524
57,0	149	1,4	25,00	SW075	90S	4	4160
57,0	156	3,8	25,00	SW105	90S	4	5816
48,0	165	0,9	30,00	SW063	90S	4	3745
48,0	174	2,5	30,00	SW090	90S	4	4891
48,0	176	3,5	30,00	SW105	90S	4	6181
48,0	170	1,5	30,00	SW075	90S	4	4421
48,0	159	1,0	60,00	SW075	80B	2	4421
48,0	181	2,4	20,00	SW090	100LR	6	4951
48,0	186	3,6	20,00	SW105	100LR	6	6256
47,5	165	1,5	60,00	SW090	80B	2	4891

## 1,10 kW

n2 [rpm]	M2 [Nm]	fs	i	Gear reducer	Motor		Fr2 [N]
					Size	Pole	
38,0	221	1,8	25,00	SW090	100LR	6	5333
38,0	227	2,9	25,00	SW105	100LR	6	6739
36,0	215	1,1	40,00	SW075	90S	4	4865
36,0	197	0,7	80,00	SW075	80B	2	4865
36,0	206	1,1	80,00	SW090	80B	2	5383
35,8	223	1,7	40,00	SW090	90S	4	5383
35,8	232	2,7	40,00	SW105	90S	4	6803
35,4	218	1,7	80,00	SW105	80B	2	6803
32,0	252	1,9	30,00	SW090	100LR	6	5667
32,0	255	2,7	30,00	SW105	100LR	6	7161
28,6	268	1,4	50,00	SW090	90S	4	5799
28,6	279	2,1	50,00	SW105	90S	4	7328
28,3	242	0,8	100,00	SW090	80B	2	5799
28,3	257	1,3	100,00	SW105	80B	2	7328
24,0	309	1,1	60,00	SW090	90S	4	6163
24,0	332	2,1	40,00	SW105	100LR	6	7882
23,5	326	1,7	60,00	SW105	90S	4	7787
19,0	398	1,7	50,00	SW105	100LR	6	8491
18,0	400	1,2	80,00	SW105	90S	4	8571
16,0	458	1,4	60,00	SW105	100LR	6	9023
14,0	470	1,0	100,00	SW105	90S	4	9232

## 1,50 kW

n2 [rpm]	M2 [Nm]	fs	i	Gear reducer	Motor		Fr2 [N]
					Size	Pole	
381,7	34	2,8	7,50	SW063	90S	2	1873
381,7	34	3,8	7,50	SW075	90S	2	2210
286,0	45	2,2	10,00	SW063	90S	2	2061
286,0	45	3,4	10,00	SW075	90S	2	2433
191,0	67	1,9	7,50	SW063	90L	4	2359
191,0	67	2,8	7,50	SW075	90L	4	2785
190,3	66	1,7	15,00	SW063	90S	2	2359
190,3	67	2,5	15,00	SW075	90S	2	2785
143,0	87	1,5	10,00	SW063	90L	4	2597
143,0	85	1,2	20,00	SW063	90S	2	2597
143,0	88	2,3	10,00	SW075	90L	4	3065
143,0	86	2,0	20,00	SW075	90S	2	3065
143,0	89	3,8	10,00	SW090	90L	4	3391
143,0	88	2,9	20,00	SW090	90S	2	3391
125,0	101	2,1	7,50	SW075	100L	6	3227
125,0	102	3,7	7,50	SW090	100L	6	3570
114,8	110	4,0	25,00	SW105	90S	2	4616

## 1,50 kW

n <sub>2</sub> [rpm]	M <sub>2</sub> [Nm]	f <sub>s</sub>	i	Gear reducer	Motor		Fr <sub>2</sub> [N]
					Size	Pole	
114,6	104	0,9	25,00	SW063	90S	2	2797
114,6	105	1,5	25,00	SW075	90S	2	3302
114,0	108	2,3	25,00	SW090	90S	2	3653
95,7	119	1,0	30,00	SW063	90S	2	2973
95,7	122	1,5	30,00	SW075	90S	2	3509
95,7	125	2,5	30,00	SW090	90S	2	3882
95,7	126	3,5	30,00	SW105	90S	2	4905
95,0	126	1,2	15,00	SW063	90L	4	2973
95,0	129	1,7	15,00	SW075	90L	4	3509
95,0	131	3,1	15,00	SW090	90L	4	3882
94,0	131	1,8	10,00	SW075	100L	6	3551
94,0	133	3,1	10,00	SW090	100L	6	3929
71,7	157	1,2	40,00	SW075	90S	2	3862
71,7	161	1,7	40,00	SW090	90S	2	4273
71,7	167	2,5	40,00	SW105	90S	2	5399
71,5	164	0,9	20,00	SW063	90L	4	3272
71,5	166	1,4	20,00	SW075	90L	4	3862
71,5	170	2,2	20,00	SW090	90L	4	4273
63,0	190	1,4	15,00	SW075	100L	6	4065
63,0	194	2,4	15,00	SW090	100L	6	4498
63,0	197	3,4	15,00	SW105	100L	6	5684
57,0	203	1,1	25,00	SW075	90L	4	4160
57,0	208	1,8	25,00	SW090	90L	4	4603
57,0	193	1,4	50,00	SW090	90S	2	4603
57,0	213	2,8	25,00	SW105	90L	4	5816
56,8	201	2,0	50,00	SW105	90S	2	5816
48,0	238	1,8	30,00	SW090	90L	4	4891
48,0	241	2,6	30,00	SW105	90L	4	6181
47,8	226	1,1	60,00	SW090	90S	2	4891
47,8	235	1,8	60,00	SW105	90S	2	6181
47,5	250	1,7	20,00	SW090	100L	6	4951
47,5	256	2,6	20,00	SW105	100L	6	6256
47,3	225	0,7	30,00	SW063	90L	4	3745
47,3	231	1,1	30,00	SW075	90L	4	4421
38,0	305	1,3	25,00	SW090	100L	6	5333
37,4	313	2,1	25,00	SW105	100L	6	6739
36,0	293	0,8	40,00	SW075	90L	4	4865
36,0	305	1,3	40,00	SW090	90L	4	5383
36,0	317	2,0	40,00	SW105	90L	4	6803
36,0	297	1,3	80,00	SW105	90S	2	6803
31,3	347	1,4	30,00	SW090	100L	6	5667
31,3	352	2,0	30,00	SW105	100L	6	7161

## 1,50 kW

n <sub>2</sub> [rpm]	M <sub>2</sub> [Nm]	f <sub>s</sub>	i	Gear reducer	Motor		Fr <sub>2</sub> [N]
					Size	Pole	
29,0	366	1,0	50,00	SW090	90L	4	5799
29,0	381	1,5	50,00	SW105	90L	4	7328
29,0	351	1,0	100,00	SW105	90S	2	7328
24,2	421	0,8	60,00	SW090	90L	4	6163
24,0	445	1,3	60,00	SW105	90L	4	7787
23,2	457	1,5	40,00	SW105	100L	6	7882
19,2	549	1,2	50,00	SW105	100L	6	8491
18,4	545	0,9	80,00	SW105	90L	4	8571
16,2	631	1,0	60,00	SW105	100L	6	9023
14,1	642	0,7	100,00	SW105	90L	4	9232

## 2,20 kW

n <sub>2</sub> [rpm]	M <sub>2</sub> [Nm]	f <sub>s</sub>	i	Gear reducer	Motor		Fr <sub>2</sub> [N]
					Size	Pole	
384,0	50	1,9	7,50	SW063	90L	2	1873
384,0	50	2,6	7,50	SW075	90L	2	2210
288,0	65	1,5	10,00	SW063	90L	2	2061
288,0	66	2,3	10,00	SW075	90L	2	2433
288,0	66	3,6	10,00	SW090	90L	2	2692
192,3	95	1,1	15,00	SW063	90L	2	2359
192,3	96	1,7	15,00	SW075	90L	2	2785
192,3	97	2,8	15,00	SW090	90L	2	3081
191,7	98	1,9	7,50	SW075	100LA	4	2785
191,7	99	3,2	7,50	SW090	100LA	4	3081
144,0	124	0,8	20,00	SW063	90L	2	2597
144,0	129	1,6	10,00	SW075	100LA	4	3065
144,0	125	1,4	20,00	SW075	90L	2	3065
144,0	130	2,6	10,00	SW090	100LA	4	3391
144,0	128	2,0	20,00	SW090	90L	2	3391
128,0	144	1,4	7,50	SW075	112M	6	3227
128,0	146	2,6	7,50	SW090	112M	6	3570
115,0	153	1,0	25,00	SW075	90L	2	3302
115,0	157	1,6	25,00	SW090	90L	2	3653
114,8	161	2,7	25,00	SW105	90L	2	4616
96,0	188	1,2	10,00	SW075	112M	6	3551
96,0	191	2,2	10,00	SW090	112M	6	3929
96,0	182	1,7	30,00	SW090	90L	2	3882
96,0	193	3,4	10,00	SW105	112M	6	4965
96,0	184	2,4	30,00	SW105	90L	2	4905
95,7	189	1,2	15,00	SW075	100LA	4	3509
95,7	178	1,0	30,00	SW075	90L	2	3509
95,7	191	2,1	15,00	SW090	100LA	4	3882

## 2,20 kW

n2 [rpm]	M2 [Nm]	fs	i	Gear reducer	Motor		Fr2 [N]
					Size	Pole	
95,7	191	3,0	15,00	SW105	100LA	4	4905
72,5	233	1,2	40,00	SW090	90L	2	4273
72,5	242	1,7	40,00	SW105	90L	2	5399
72,0	228	0,8	40,00	SW075	90L	2	3862
72,0	249	1,6	20,00	SW090	100LA	4	4273
72,0	251	2,4	20,00	SW105	100LA	4	5399
64,0	272	0,9	15,00	SW075	112M	6	4065
64,0	279	1,7	15,00	SW090	112M	6	4498
64,0	282	2,4	15,00	SW105	112M	6	5684
58,0	292	1,4	50,00	SW105	90L	2	5816
57,4	281	0,9	50,00	SW090	90L	2	4603
57,2	303	1,3	25,00	SW090	100LA	4	4603
57,2	310	1,9	25,00	SW105	100LA	4	5816
48,5	368	1,9	20,00	SW105	112M	6	6256
48,3	329	0,7	60,00	SW090	90L	2	4891
48,3	351	1,7	30,00	SW105	100LA	4	6181
48,3	342	1,3	60,00	SW105	90L	2	6181
48,0	359	1,2	20,00	SW090	112M	6	4951
47,7	346	1,2	30,00	SW090	100LA	4	4891
38,0	438	0,9	25,00	SW090	112M	6	5333
38,0	449	1,5	25,00	SW105	112M	6	6739
36,5	462	1,3	40,00	SW105	100LA	4	6803
36,0	432	0,9	80,00	SW105	90L	2	6803
32,0	499	1,0	30,00	SW090	112M	6	5667
32,0	506	1,4	30,00	SW105	112M	6	7161
28,6	555	1,1	50,00	SW105	100LA	4	7328
24,0	657	1,1	40,00	SW105	112M	6	7882
24,0	648	0,9	60,00	SW105	100LA	4	7787
19,0	788	0,8	50,00	SW105	112M	6	8491
16,0	906	0,7	60,00	SW105	112M	6	9023

## 3,00 kW

n2 [rpm]	M2 [Nm]	fs	i	Gear reducer	Motor		Fr2 [N]
					Size	Pole	
387,0	67	1,9	7,50	SW075	100L	2	2210
387,0	68	3,0	7,50	SW090	100L	2	2446
290,0	89	1,7	10,00	SW075	100L	2	2433
290,0	89	2,6	10,00	SW090	100L	2	2692
290,0	90	4,0	10,00	SW105	100L	2	3401
193,0	132	1,4	7,50	SW075	112MS	4	2785
193,0	133	2,4	7,50	SW090	112MS	4	3081
193,0	132	2,0	15,00	SW090	100L	2	3081



## 3,00 kW

n2 [rpm]	M2 [Nm]	fs	i	Gear reducer	Motor		Fr2 [N]
					Size	Pole	
193,0	133	4,0	7,50	SW105	112MS	4	3893
193,0	131	1,3	15,00	SW075	100L	2	2785
193,0	134	3,0	15,00	SW105	100L	2	3893
145,5	174	1,5	20,00	SW090	100L	2	3391
145,5	176	2,3	20,00	SW105	100L	2	4285
145,0	174	1,2	10,00	SW075	112MS	4	3065
145,0	176	1,9	10,00	SW090	112MS	4	3391
145,0	176	3,1	10,00	SW105	112MS	4	4285
129,0	197	3,2	7,50	SW105	132S	6	4511
116,2	213	1,2	25,00	SW090	100L	2	3653
116,2	218	2,0	25,00	SW105	100L	2	4616
97,0	246	1,2	30,00	SW090	100L	2	3882
97,0	249	1,7	30,00	SW105	100L	2	4905
97,0	255	0,9	15,00	SW075	112MS	4	3509
97,0	258	1,5	15,00	SW090	112MS	4	3882
97,0	260	2,5	10,00	SW105	132S	6	4965
97,0	258	2,3	15,00	SW105	112MS	4	4905
73,0	336	1,2	20,00	SW090	112MS	4	4273
73,0	340	1,8	20,00	SW105	112MS	4	5399
73,0	328	1,3	40,00	SW105	100L	2	5399
64,7	381	1,7	15,00	SW105	132S	6	5684
58,0	410	0,9	25,00	SW090	112MS	4	4603
58,0	420	1,4	25,00	SW105	112MS	4	5816
58,0	395	1,0	50,00	SW105	100L	2	5816
49,0	496	1,4	20,00	SW105	132S	6	6256
48,5	462	0,9	60,00	SW105	100L	2	6181
48,0	468	0,9	30,00	SW090	112MS	4	4891
48,0	474	1,3	30,00	SW105	112MS	4	6181
36,0	624	1,0	40,00	SW105	112MS	4	6803
29,0	751	0,8	50,00	SW105	112MS	4	7328

## 4,00 kW

n2 [rpm]	M2 [Nm]	fs	i	Gear reducer	Motor		Fr2 [N]
					Size	Pole	
391,0	89	1,5	7,50	SW075	112M	2	2210
391,0	90	2,3	7,50	SW090	112M	2	2446
391,0	90	3,7	7,50	SW105	112M	2	3090
293,0	118	1,3	10,00	SW075	112M	2	2433
293,0	118	2,0	10,00	SW090	112M	2	2692
293,0	119	3,1	10,00	SW105	112M	2	3401
195,0	172	0,9	15,00	SW075	112M	2	2785
195,0	174	1,5	15,00	SW090	112M	2	3081

## 4,00 kW

n <sub>2</sub> [rpm]	M <sub>2</sub> [Nm]	f <sub>s</sub>	i	Gear reducer	Motor		Fr <sub>2</sub> [N]
					Size	Pole	
195,0	176	2,3	15,00	SW105	112M	2	3893
193,0	176	1,1	7,50	SW075	112M	4	2785
193,0	178	1,8	7,50	SW090	112M	4	3081
193,0	178	3,0	7,50	SW105	112M	4	3893
147,0	232	1,7	20,00	SW105	112M	2	4285
146,5	230	1,1	20,00	SW090	112M	2	3391
145,0	232	0,9	10,00	SW075	112M	4	3065
145,0	234	1,4	10,00	SW090	112M	4	3391
145,0	234	2,3	10,00	SW105	112M	4	4285
129,3	263	2,3	7,50	SW105	132MA	6	4511
117,2	280	0,9	25,00	SW090	112M	2	3653
117,2	287	1,5	25,00	SW105	112M	2	4616
98,0	325	1,0	30,00	SW090	112M	2	3882
98,0	329	1,3	30,00	SW105	112M	2	4905
97,0	344	1,2	15,00	SW090	112M	4	3882
97,0	347	1,9	10,00	SW105	132MA	6	4965
97,0	344	1,7	15,00	SW105	112M	4	4905
73,0	448	0,9	20,00	SW090	112M	4	4273
73,0	453	1,3	20,00	SW105	112M	4	5399
73,0	433	1,0	40,00	SW105	112M	2	5399
65,0	508	1,3	15,00	SW105	132MA	6	5684
59,0	522	0,8	50,00	SW105	112M	2	5816
58,4	560	1,0	25,00	SW105	112M	4	5816
49,0	610	0,7	60,00	SW105	112M	2	6181
48,5	662	1,0	20,00	SW105	132MA	6	6256
48,3	633	1,0	30,00	SW105	112M	4	6181
36,2	832	0,7	40,00	SW105	112M	4	6803

## 5,50 kW

n <sub>2</sub> [rpm]	M <sub>2</sub> [Nm]	f <sub>s</sub>	i	Gear reducer	Motor		Fr <sub>2</sub> [N]
					Size	Pole	
393,3	123	2,7	7,50	SW105	132S	2	3090
295,0	162	2,2	10,00	SW105	132S	2	3401
196,7	241	1,7	15,00	SW105	132S	2	3893
195,7	242	2,2	7,50	SW105	132MS	4	3893
148,0	317	1,3	20,00	SW105	132S	2	4285
147,0	318	1,7	10,00	SW105	132MS	4	4285
129,3	361	1,7	7,50	SW105	132MB	6	4511
98,3	467	1,2	15,00	SW105	132MS	4	4905
97,0	477	1,4	10,00	SW105	132MB	6	4965
74,0	615	1,0	20,00	SW105	132MS	4	5399
65,0	699	1,0	15,00	SW105	132MB	6	5684

## 5,50 kW

n2 [rpm]	M2 [Nm]	fs	i	Gear reducer	Size	Motor	Pole	Fr2 [N]
49,0	910	0,7	20,00	SW105	132MB		6	6256

## 7,50 kW

n2 [rpm]	M2 [Nm]	fs	i	Gear reducer	Size	Motor	Pole	Fr2 [N]
393,0	168	2,0	7,50	SW105	132M		2	3090
295,0	221	1,6	10,00	SW105	132M		2	3401
197,0	328	1,2	15,00	SW105	132M		2	3893
195,0	331	1,6	7,50	SW105	132M		4	3893
148,0	432	0,9	20,00	SW105	132M		2	4285
146,0	437	1,3	10,00	SW105	132M		4	4285
97,7	641	0,9	15,00	SW105	132M		4	4905
73,5	844	0,7	20,00	SW105	132M		4	5399

## ISW030

$Mn_2$ [Nm]	$i$	$Pn_1$ [kW]	$n_2$ [rpm]	$Fr_1$ [N]	$Fr_2$ [N]
12	5,00	0,79	560,0	115	474
13	7,50	0,58	373,0	125	542
13	10,00	0,44	280,0	140	597
13	15,00	0,31	187,0	140	683
12	20,00	0,22	140,0	146	752
16	25,00	0,25	112,0	210	810
15	30,00	0,20	93,0	210	861
14	40,00	0,15	70,0	127	948
13	50,00	0,12	56,0	128	1021
12	60,00	0,10	47,0	126	1085
11	80,00	0,08	35,0	130	1194

## ISW040

$Mn_2$ [Nm]	$i$	$Pn_1$ [kW]	$n_2$ [rpm]	$Fr_1$ [N]	$Fr_2$ [N]
24	5,00	1,56	560,0	200	912
28	7,50	1,23	373,0	233	1044
29	10,00	0,97	280,0	272	1149
31	15,00	0,71	187,0	291	1315
29	20,00	0,51	140,0	204	1447
28	25,00	0,41	112,0	236	1559
34	30,00	0,43	93,0	350	1657
31	40,00	0,31	70,0	350	1824
30	50,00	0,25	56,0	350	1964
28	60,00	0,21	47,0	350	2087
25	80,00	0,15	35,0	350	2298
23	100,00	0,12	28,0	350	2475

## ISW050

$Mn_2$ [Nm]	$i$	$Pn_1$ [kW]	$n_2$ [rpm]	$Fr_1$ [N]	$Fr_2$ [N]
45	5,00	2,90	560,0	280	1251
52	7,50	2,26	373,0	324	1433
54	10,00	1,78	280,0	378	1577
57	15,00	1,30	187,0	399	1805
53	20,00	0,94	140,0	417	1987
51	25,00	0,74	112,0	482	2140
64	30,00	0,81	93,0	490	2274
59	40,00	0,58	70,0	490	2503
53	50,00	0,44	56,0	490	2696
50	60,00	0,36	47,0	490	2865

## ISW050

$Mn_2$ [Nm]	i	$Pn_1$ [kW]	n2 [rpm]	Fr1 [N]	Fr2 [N]
45	80,00	0,27	35,0	490	3153
40	100,00	0,21	28,0	490	3397

## ISW063

$Mn_2$ [Nm]	i	$Pn_1$ [kW]	n2 [rpm]	Fr1 [N]	Fr2 [N]
94	7,50	4,03	373,0	395	1873
99	10,00	3,27	280,0	471	2061
109	15,00	2,45	187,0	516	2359
104	20,00	1,80	140,0	556	2597
96	25,00	1,35	112,0	613	2797
121	30,00	1,49	93,0	700	2973
113	40,00	1,09	70,0	700	3272
105	50,00	0,85	56,0	700	3524
99	60,00	0,70	47,0	700	3745
88	80,00	0,50	35,0	700	4122
79	100,00	0,39	28,0	700	4440

## ISW075

$Mn_2$ [Nm]	i	$Pn_1$ [kW]	n2 [rpm]	Fr1 [N]	Fr2 [N]
131	7,50	5,61	373,0	560	2210
151	10,00	4,93	280,0	729	2433
165	15,00	3,66	187,0	795	2785
173	20,00	2,94	140,0	935	3065
159	25,00	2,21	112,0	980	3302
185	30,00	2,24	93,0	980	3509
182	40,00	1,71	70,0	980	3862
165	50,00	1,29	56,0	980	4160
159	60,00	1,08	47,0	980	4421
141	80,00	0,77	35,0	980	4865
131	100,00	0,62	28,0	980	5241

## ISW090

$Mn_2$ [Nm]	i	$Pn_1$ [kW]	n2 [rpm]	Fr1 [N]	Fr2 [N]
210	7,50	8,92	373,0	715	2446
235	10,00	7,66	280,0	900	2692
270	15,00	5,93	187,0	1034	3081
260	20,00	4,33	140,0	1120	3391

## ISW090

$Mn_2$ [Nm]	$i$	$Pn_1$ [kW]	$n_2$ [rpm]	$Fr_1$ [N]	$Fr_2$ [N]
250	25,00	3,41	112,0	1270	3653
310	30,00	3,65	93,0	1270	3882
275	40,00	2,52	70,0	1270	4273
265	50,00	2,02	56,0	1270	4603
245	60,00	1,60	47,0	1270	4891
225	80,00	1,18	35,0	1270	5383
200	100,00	0,89	28,0	1270	5799

## ISW105

$Mn_2$ [Nm]	$i$	$Pn_1$ [kW]	$n_2$ [rpm]	$Fr_1$ [N]	$Fr_2$ [N]
340	7,50	14,45	373,0	1270	3090
363	10,00	11,70	280,0	1270	3401
406	15,00	8,82	187,0	1270	3893
401	20,00	6,61	140,0	1270	4285
440	25,00	5,86	112,0	1270	4616
437	30,00	5,08	93,0	1270	4905
419	40,00	3,70	70,0	1270	5399
409	50,00	3,00	56,0	1270	5816
430	60,00	2,69	47,0	1270	6181
380	80,00	1,88	35,0	1270	6803
350	100,00	1,47	28,0	1270	7328

## ISW030/040

$Mn_2$ [Nm]	$i$	$Pn_1$ [kW]	$n_2$ [rpm]	$Fr_1$ [N]	$Fr_2$ [N]
71	100,00	0,31	28,0	140	2769
72	150,00	0,22	18,7	140	3169
65	200,00	0,16	14,0	140	3488
61	250,00	0,13	11,2	140	3490
73	300,00	0,14	9,3	140	3490
65	400,00	0,10	7,0	140	3490
61	500,00	0,07	5,6	146	3490
73	600,00	0,08	4,7	146	3490
73	750,00	0,06	3,7	210	3490
73	900,00	0,06	3,1	210	3490
73	1200,00	0,04	2,3	127	3490
73	1500,00	0,04	1,9	128	3490
73	1800,00	0,03	1,6	126	3490
65	2400,00	0,03	1,2	126	3490
60	3000,00	0,02	0,9	126	3490
48	4000,00	0,01	0,7	128	3490
43	5000,00	0,01	0,6	128	3490

## ISW030/050

$Mn_2$ [Nm]	$i$	$Pn_1$ [kW]	$n_2$ [rpm]	$Fr_1$ [N]	$Fr_2$ [N]
103	100,00	0,44	28,0	140	3800
135	150,00	0,42	18,7	140	4350
120	200,00	0,30	14,0	140	4788
110	250,00	0,23	11,2	140	4840
145	300,00	0,27	9,3	140	4840
124	400,00	0,20	7,0	140	4840
120	500,00	0,16	5,6	140	4840
145	600,00	0,15	4,7	146	4840
145	750,00	0,13	3,7	210	4840
145	900,00	0,11	3,1	210	4840
145	1200,00	0,09	2,3	127	4840
145	1500,00	0,07	1,9	128	4840
145	1800,00	0,07	1,6	126	4840
124	2400,00	0,05	1,2	126	4840
120	3000,00	0,04	0,9	126	4840
82	4000,00	0,02	0,7	128	4840
79	5000,00	0,02	0,6	128	4840

## ISW030/063

$Mn_2$ [Nm]	$i$	$Pn_1$ [kW]	$n_2$ [rpm]	$Fr_1$ [N]	$Fr_2$ [N]
103	100,00	0,44	28,0	140	4967
103	150,00	0,31	18,7	140	4967
95	200,00	0,22	14,0	146	4967
126	250,00	0,25	11,2	210	4967
255	300,00	0,51	9,3	125	6270
255	400,00	0,39	7,0	140	6270
236	500,00	0,31	5,6	140	6270
220	600,00	0,22	4,7	146	6270
271	750,00	0,23	3,7	210	6270
271	900,00	0,20	3,1	210	6270
256	1200,00	0,15	2,3	127	6270
238	1500,00	0,12	1,9	128	6270
220	1800,00	0,10	1,6	126	6270
255	2400,00	0,09	1,2	126	6270
236	3000,00	0,08	0,9	126	6270
236	4000,00	0,06	0,7	130	6270
150	5000,00	0,04	0,6	128	6270

## ISW040/075

$Mn_2$ [Nm]	$i$	$Pn_1$ [kW]	$n_2$ [rpm]	$Fr_1$ [N]	$Fr_2$ [N]
232	100,00	0,97	28,0	272	5863
331	150,00	0,97	18,7	272	6712
418	200,00	0,97	14,0	272	7380
380	250,00	0,73	11,2	272	7380
444	300,00	0,77	9,3	272	7380
414	400,00	0,58	7,0	272	7380
368	500,00	0,45	5,6	272	7380
444	600,00	0,41	4,7	204	7380
444	750,00	0,34	3,7	236	7380
444	900,00	0,29	3,1	350	7380
444	1200,00	0,23	2,3	350	7380
444	1500,00	0,20	1,9	350	7380
444	1800,00	0,17	1,6	350	7380
414	2400,00	0,13	1,2	350	7380
368	3000,00	0,10	0,9	350	7380
368	4000,00	0,08	0,7	350	7380
368	5000,00	0,07	0,6	350	7380



## ISW040/090

$Mn_2$ [Nm]	$i$	$Pn_1$ [kW]	$n_2$ [rpm]	$Fr_1$ [N]	$Fr_2$ [N]
238	100,00	0,97	28,0	272	6487
254	150,00	0,71	18,7	291	6487
238	200,00	0,51	14,0	204	6487
522	250,00	0,97	11,2	272	8180
583	300,00	0,97	9,3	272	8180
610	400,00	0,82	7,0	272	8180
560	500,00	0,64	5,6	272	8180
583	600,00	0,51	4,7	204	8180
563	750,00	0,41	3,7	236	8180
683	900,00	0,43	3,1	350	8180
623	1200,00	0,31	2,3	350	8180
603	1500,00	0,25	1,9	350	8180
563	1800,00	0,21	1,6	350	8180
610	2400,00	0,18	1,2	350	8180
560	3000,00	0,14	0,9	350	8180
560	4000,00	0,12	0,7	350	8180
560	5000,00	0,10	0,6	350	8180

## ISW050/090

$Mn_2$ [Nm]	$i$	$Pn_1$ [kW]	$n_2$ [rpm]	$Fr_1$ [N]	$Fr_2$ [N]
443	100,00	1,78	28,0	378	6487
632	150,00	1,78	18,7	378	7426
610	200,00	1,34	14,0	378	8174
570	250,00	1,04	11,2	378	8180
700	300,00	1,15	9,3	378	8180
610	400,00	0,81	7,0	378	8180
570	500,00	0,56	5,6	417	8180
700	600,00	0,62	4,7	417	8180
700	750,00	0,50	3,7	482	8180
700	900,00	0,44	3,1	490	8180
700	1200,00	0,34	2,3	490	8180
700	1500,00	0,29	1,9	490	8180
700	1800,00	0,25	1,6	490	8180
610	2400,00	0,18	1,2	490	8180
560	3000,00	0,14	0,9	490	8180
560	4000,00	0,11	0,7	490	8180
560	5000,00	0,10	0,6	490	8180

## ISW050/105

$Mn_2$ [Nm]	$i$	$Pn_1$ [kW]	$n_2$ [rpm]	$Fr_1$ [N]	$Fr_2$ [N]
443	100,00	1,78	28,0	378	8198
640	150,00	1,78	18,7	378	9384
832	200,00	1,78	14,0	378	10320
1013	250,00	1,78	11,2	378	10320
1085	300,00	1,78	9,3	378	10320
1030	400,00	1,31	7,0	378	10320
994	500,00	0,94	5,6	417	10320
1065	600,00	0,94	4,7	417	10320
1025	750,00	0,74	3,7	482	10320
1100	900,00	0,69	3,1	490	10320
1100	1200,00	0,54	2,3	490	10320
1065	1500,00	0,44	1,9	490	10320
1005	1800,00	0,36	1,6	490	10320
1030	2400,00	0,29	1,2	490	10320
1000	3000,00	0,24	0,9	490	10320
1000	4000,00	0,19	0,7	490	10320
1000	5000,00	0,17	0,6	490	10320

## ISW030

$Mn_2$ [Nm]	$i$	$Pn_1$ [kW]	$n_2$ [rpm]	$Fr_1$ [N]	$Fr_2$ [N]
18	5,00	0,76	350,0	150	554
18	7,50	0,52	233,0	150	634
18	10,00	0,40	175,0	169	698
18	15,00	0,28	117,0	169	799
17	20,00	0,21	88,0	179	880
21	25,00	0,22	70,0	210	948
20	30,00	0,19	58,0	210	1007
18	40,00	0,14	44,0	210	1108
17	50,00	0,11	35,0	210	1194
15	60,00	0,09	29,0	210	1269
12	80,00	0,06	22,0	210	1396

## ISW040

$Mn_2$ [Nm]	$i$	$Pn_1$ [kW]	$n_2$ [rpm]	$Fr_1$ [N]	$Fr_2$ [N]
34	5,00	1,41	350,0	250	1066
40	7,50	1,12	233,0	291	1221
42	10,00	0,90	175,0	343	1344
42	15,00	0,62	117,0	343	1538
41	20,00	0,47	88,0	350	1693
37	25,00	0,36	70,0	350	1824
46	30,00	0,39	58,0	350	1938
43	40,00	0,30	44,0	350	2133
40	50,00	0,23	35,0	350	2298
36	60,00	0,19	29,0	350	2442
31	80,00	0,14	22,0	350	2687
28	100,00	0,11	18,0	350	2895

## ISW050

$Mn_2$ [Nm]	$i$	$Pn_1$ [kW]	$n_2$ [rpm]	$Fr_1$ [N]	$Fr_2$ [N]
65	5,00	2,66	350,0	350	1464
73	7,50	2,03	233,0	396	1676
75	10,00	1,58	175,0	490	1844
77	15,00	1,13	117,0	490	2111
74	20,00	0,85	88,0	490	2324
67	25,00	0,64	70,0	490	2503
84	30,00	0,70	58,0	490	2660
78	40,00	0,52	44,0	490	2927
73	50,00	0,42	35,0	490	3153
68	60,00	0,35	29,0	490	3351

## ISW050

$Mn_2$ [Nm]	i	$Pn_1$ [kW]	n2 [rpm]	Fr1 [N]	Fr2 [N]
62	80,00	0,26	22,0	490	3688
52	100,00	0,19	18,0	490	3973

## ISW063

$Mn_2$ [Nm]	i	$Pn_1$ [kW]	n2 [rpm]	Fr1 [N]	Fr2 [N]
122	7,50	3,32	233,0	500	2190
125	10,00	2,63	175,0	579	2411
140	15,00	2,02	117,0	646	2759
138	20,00	1,53	88,0	700	3037
127	25,00	1,17	70,0	700	3272
152	30,00	1,22	58,0	700	3477
142	40,00	0,91	44,0	700	3827
136	50,00	0,73	35,0	700	4122
128	60,00	0,61	29,0	700	4380
116	80,00	0,45	22,0	700	4821
112	100,00	0,38	18,0	700	5193

## ISW075

$Mn_2$ [Nm]	i	$Pn_1$ [kW]	n2 [rpm]	Fr1 [N]	Fr2 [N]
176	7,50	4,80	233,0	700	2585
187	10,00	3,88	175,0	839	2845
215	15,00	3,03	117,0	962	3257
221	20,00	2,42	88,0	980	3585
202	25,00	1,81	70,0	980	3862
229	30,00	1,80	58,0	980	4104
229	40,00	1,42	44,0	980	4517
212	50,00	1,10	35,0	980	4865
201	60,00	0,91	29,0	980	5170
184	80,00	0,68	22,0	980	5691
171	100,00	0,55	18,0	980	6130

## ISW090

$Mn_2$ [Nm]	i	$Pn_1$ [kW]	n2 [rpm]	Fr1 [N]	Fr2 [N]
303	7,50	8,19	233,0	900	2860
324	10,00	6,65	175,0	1082	3148
376	15,00	5,26	117,0	1257	3604
371	20,00	3,97	88,0	1270	3967

## ISW090

$Mn_2$ [Nm]	$i$	$Pn_1$ [kW]	$n_2$ [rpm]	$Fr_1$ [N]	$Fr_2$ [N]
355	25,00	3,11	70,0	1270	4273
410	30,00	3,14	58,0	1270	4541
376	40,00	2,24	44,0	1270	4998
355	50,00	1,76	35,0	1270	5383
334	60,00	1,44	29,0	1270	5721
271	80,00	0,95	22,0	1270	6297
257	100,00	0,77	18,0	1270	6783

## ISW105

$Mn_2$ [Nm]	$i$	$Pn_1$ [kW]	$n_2$ [rpm]	$Fr_1$ [N]	$Fr_2$ [N]
504	7,50	13,62	233,0	1270	3614
518	10,00	10,61	175,0	1270	3978
552	15,00	7,69	117,0	1270	4554
566	20,00	5,99	88,0	1270	5012
560	25,00	4,79	70,0	1270	5399
574	30,00	4,34	58,0	1270	5737
588	40,00	3,37	44,0	1270	6315
558	50,00	2,66	35,0	1270	6803
546	60,00	2,23	29,0	1270	7229
465	80,00	1,54	22,0	1270	7956
437	100,00	1,23	18,0	1270	8571

## ISW030/040

Mn <sub>2</sub> [Nm]	i	Pn <sub>1</sub> [kW]	n <sub>2</sub> [rpm]	Fr1 [N]	Fr2 [N]
71	100,00	0,20	17,5	169	2769
72	150,00	0,15	11,7	169	3169
65	200,00	0,10	8,8	169	3488
61	250,00	0,08	7,0	169	3490
73	300,00	0,09	5,8	169	3490
65	400,00	0,07	4,4	169	3490
61	500,00	0,05	3,5	179	3490
73	600,00	0,05	2,9	179	3490
73	750,00	0,04	2,3	210	3490
73	900,00	0,04	1,9	210	3490
73	1200,00	0,03	1,5	210	3490
73	1500,00	0,03	1,2	210	3490
73	1800,00	0,02	1,0	210	3490
65	2400,00	0,02	0,7	210	3490
60	3000,00	0,01	0,6	210	3490
48	4000,00	0,01	0,4	210	3490
43	5000,00	0,01	0,4	210	3490

## ISW030/050

Mn <sub>2</sub> [Nm]	i	Pn <sub>1</sub> [kW]	n <sub>2</sub> [rpm]	Fr1 [N]	Fr2 [N]
137	100,00	0,38	17,5	169	3800
135	150,00	0,27	11,7	169	4350
120	200,00	0,19	8,8	169	4788
110	250,00	0,15	7,0	169	4840
145	300,00	0,18	5,8	169	4840
124	400,00	0,13	4,4	169	4840
120	500,00	0,11	3,5	169	4840
145	600,00	0,10	2,9	179	4840
145	750,00	0,09	2,3	210	4840
145	900,00	0,07	1,9	210	4840
145	1200,00	0,06	1,5	210	4840
145	1500,00	0,05	1,2	210	4840
145	1800,00	0,05	1,0	210	4840
124	2400,00	0,03	0,7	210	4840
120	3000,00	0,03	0,6	210	4840
82	4000,00	0,02	0,4	210	4840
79	5000,00	0,01	0,4	210	4840

## ISW030/063

$Mn_2$ [Nm]	$i$	$Pn_1$ [kW]	$n_2$ [rpm]	$Fr_1$ [N]	$Fr_2$ [N]
143	100,00	0,40	17,5	169	4967
143	150,00	0,28	11,7	169	4967
135	200,00	0,21	8,8	179	4967
165	250,00	0,22	7,0	210	4967
255	300,00	0,33	5,8	150	6270
255	400,00	0,25	4,4	169	6270
236	500,00	0,20	3,5	169	6270
271	600,00	0,18	2,9	179	6270
271	750,00	0,16	2,3	210	6270
271	900,00	0,14	1,9	210	6270
271	1200,00	0,11	1,5	210	6270
271	1500,00	0,10	1,2	210	6270
271	1800,00	0,09	1,0	210	6270
255	2400,00	0,07	0,7	210	6270
236	3000,00	0,05	0,6	210	6270
236	4000,00	0,05	0,4	210	6270
150	5000,00	0,03	0,4	210	6270

## ISW040/075

$Mn_2$ [Nm]	$i$	$Pn_1$ [kW]	$n_2$ [rpm]	$Fr_1$ [N]	$Fr_2$ [N]
335	100,00	0,90	17,5	343	5863
425	150,00	0,80	11,7	343	6712
420	200,00	0,63	8,8	343	7380
380	250,00	0,47	7,0	343	7380
444	300,00	0,50	5,8	343	7380
414	400,00	0,38	4,4	343	7380
368	500,00	0,29	3,5	343	7380
444	600,00	0,27	2,9	350	7380
444	750,00	0,22	2,3	350	7380
444	900,00	0,20	1,9	350	7380
444	1200,00	0,16	1,5	350	7380
444	1500,00	0,13	1,2	350	7380
444	1800,00	0,12	1,0	350	7380
414	2400,00	0,09	0,7	350	7380
368	3000,00	0,07	0,6	350	7380
368	4000,00	0,06	0,4	350	7380
368	5000,00	0,05	0,4	350	7380

## ISW040/090

$Mn_2$ [Nm]	$i$	$Pn_1$ [kW]	$n_2$ [rpm]	$Fr_1$ [N]	$Fr_2$ [N]
343	100,00	0,90	17,5	343	6487
343	150,00	0,62	11,7	343	6487
335	200,00	0,47	8,8	350	6487
570	250,00	0,68	7,0	343	8180
700	300,00	0,75	5,8	343	8180
610	400,00	0,53	4,4	343	8180
560	500,00	0,42	3,5	343	8180
700	600,00	0,40	2,9	350	8180
700	750,00	0,34	2,3	350	8180
700	900,00	0,30	1,9	350	8180
700	1200,00	0,24	1,5	350	8180
700	1500,00	0,20	1,2	350	8180
700	1800,00	0,18	1,0	350	8180
610	2400,00	0,13	0,7	350	8180
560	3000,00	0,10	0,6	350	8180
560	4000,00	0,08	0,4	350	8180
560	5000,00	0,07	0,4	350	8180

## ISW050/090

$Mn_2$ [Nm]	$i$	$Pn_1$ [kW]	$n_2$ [rpm]	$Fr_1$ [N]	$Fr_2$ [N]
590	100,00	1,52	17,5	490	6487
660	150,00	1,19	11,7	490	7426
610	200,00	0,86	8,8	490	8174
570	250,00	0,67	7,0	490	8180
700	300,00	0,73	5,8	490	8180
610	400,00	0,52	4,4	490	8180
570	500,00	0,36	3,5	490	8180
700	600,00	0,40	2,9	490	8180
700	750,00	0,33	2,3	490	8180
700	900,00	0,29	1,9	490	8180
700	1200,00	0,23	1,5	490	8180
700	1500,00	0,20	1,2	490	8180
700	1800,00	0,18	1,0	490	8180
610	2400,00	0,13	0,7	490	8180
560	3000,00	0,10	0,6	490	8180
560	4000,00	0,08	0,4	490	8180
560	5000,00	0,07	0,4	490	8180



## ISW050/105

$Mn_2$ [Nm]	$i$	$Pn_1$ [kW]	$n_2$ [rpm]	$Fr_1$ [N]	$Fr_2$ [N]
615	100,00	1,58	17,5	490	8198
889	150,00	1,58	11,7	490	9384
990	200,00	1,35	8,8	490	10320
1020	250,00	1,15	7,0	490	10320
1100	300,00	1,15	5,8	490	10320
1030	400,00	0,83	4,4	490	10320
1020	500,00	0,62	3,5	490	10320
1100	600,00	0,63	2,9	490	10320
1100	750,00	0,52	2,3	490	10320
1100	900,00	0,46	1,9	490	10320
1100	1200,00	0,37	1,5	490	10320
1100	1500,00	0,31	1,2	490	10320
1100	1800,00	0,28	1,0	490	10320
1030	2400,00	0,20	0,7	490	10320
1000	3000,00	0,16	0,6	490	10320
1000	4000,00	0,14	0,4	490	10320
1000	5000,00	0,12	0,4	490	10320

## ISW030

$Mn_2$ [Nm]	$i$	$Pn_1$ [kW]	$n_2$ [rpm]	$Fr_1$ [N]	$Fr_2$ [N]
19	5,00	0,64	280,0	150	597
19	7,50	0,44	187,0	150	683
19	10,00	0,34	140,0	169	752
19	15,00	0,24	93,0	169	861
18	20,00	0,18	70,0	180	948
22	25,00	0,19	56,0	210	1021
21	30,00	0,16	47,0	210	1085
19	40,00	0,12	35,0	210	1194
18	50,00	0,09	28,0	210	1286
16	60,00	0,08	23,0	210	1367
13	80,00	0,05	18,0	210	1504

## ISW040

$Mn_2$ [Nm]	$i$	$Pn_1$ [kW]	$n_2$ [rpm]	$Fr_1$ [N]	$Fr_2$ [N]
36	5,00	1,19	280,0	250	1149
42	7,50	0,94	187,0	292	1315
44	10,00	0,76	140,0	344	1447
44	15,00	0,52	93,0	344	1657
43	20,00	0,40	70,0	350	1824
39	25,00	0,30	56,0	350	1964
48	30,00	0,33	47,0	350	2087
45	40,00	0,25	35,0	350	2298
42	50,00	0,20	28,0	350	2475
38	60,00	0,16	23,0	350	2630
33	80,00	0,11	18,0	350	2895
29	100,00	0,09	14,0	350	3118

## ISW050

$Mn_2$ [Nm]	$i$	$Pn_1$ [kW]	$n_2$ [rpm]	$Fr_1$ [N]	$Fr_2$ [N]
68	5,00	2,24	280,0	350	1577
77	7,50	1,71	187,0	396	1805
79	10,00	1,33	140,0	490	1987
81	15,00	0,95	93,0	490	2274
78	20,00	0,71	70,0	490	2503
71	25,00	0,54	56,0	490	2696
88	30,00	0,59	47,0	490	2865
82	40,00	0,44	35,0	490	3153
77	50,00	0,35	28,0	490	3397
72	60,00	0,29	23,0	490	3610

## ISW050

$Mn_2$ [Nm]	i	$Pn_1$ [kW]	n2 [rpm]	Fr1 [N]	Fr2 [N]
65	80,00	0,22	18,0	490	3973
55	100,00	0,16	14,0	490	4280

## ISW063

$Mn_2$ [Nm]	i	$Pn_1$ [kW]	n2 [rpm]	Fr1 [N]	Fr2 [N]
128	7,50	2,81	187,0	500	2359
135	10,00	2,28	140,0	595	2597
150	15,00	1,75	93,0	660	2973
146	20,00	1,30	70,0	700	3272
134	25,00	0,99	56,0	700	3524
160	30,00	1,04	47,0	700	3745
149	40,00	0,77	35,0	700	4122
143	50,00	0,63	28,0	700	4440
135	60,00	0,52	23,0	700	4719
122	80,00	0,39	18,0	700	5193
118	100,00	0,33	14,0	700	5595

## ISW075

$Mn_2$ [Nm]	i	$Pn_1$ [kW]	n2 [rpm]	Fr1 [N]	Fr2 [N]
185	7,50	4,06	187,0	700	2785
201	10,00	3,35	140,0	857	3065
230	15,00	2,61	93,0	979	3509
236	20,00	2,09	70,0	980	3862
214	25,00	1,55	56,0	980	4160
247	30,00	1,57	47,0	980	4421
245	40,00	1,23	35,0	980	4865
225	50,00	0,94	28,0	980	5241
214	60,00	0,79	23,0	980	5569
195	80,00	0,58	18,0	980	6130
180	100,00	0,47	14,0	980	6603

## ISW090

$Mn_2$ [Nm]	i	$Pn_1$ [kW]	n2 [rpm]	Fr1 [N]	Fr2 [N]
319	7,50	6,93	187,0	900	3081
341	10,00	5,62	140,0	1082	3391
396	15,00	4,45	93,0	1257	3882
391	20,00	3,37	70,0	1270	4273

## ISW090

$Mn_2$ [Nm]	$i$	$Pn_1$ [kW]	$n_2$ [rpm]	$Fr_1$ [N]	$Fr_2$ [N]
374	25,00	2,64	56,0	1270	4603
432	30,00	2,67	47,0	1270	4891
396	40,00	1,91	35,0	1270	5383
374	50,00	1,50	28,0	1270	5799
352	60,00	1,23	23,0	1270	6163
285	80,00	0,82	18,0	1270	6783
270	100,00	0,66	14,0	1270	7306

## ISW105

$Mn_2$ [Nm]	$i$	$Pn_1$ [kW]	$n_2$ [rpm]	$Fr_1$ [N]	$Fr_2$ [N]
530	7,50	11,51	187,0	1270	3893
546	10,00	8,99	140,0	1270	4285
581	15,00	6,53	93,0	1270	4905
596	20,00	5,08	70,0	1270	5399
590	25,00	4,07	56,0	1270	5816
605	30,00	3,70	47,0	1270	6181
619	40,00	2,87	35,0	1270	6803
587	50,00	2,26	28,0	1270	7328
575	60,00	1,90	23,0	1270	7787
490	80,00	1,32	18,0	1270	8571
460	100,00	1,05	14,0	1270	9232

## ISW030/040

Mn <sub>2</sub> [Nm]	i	Pn <sub>1</sub> [kW]	n <sub>2</sub> [rpm]	Fr1 [N]	Fr2 [N]
71	100,00	0,16	14,0	169	2769
72	150,00	0,12	9,3	169	3169
65	200,00	0,08	7,0	169	3488
61	250,00	0,07	5,6	169	3490
73	300,00	0,07	4,7	169	3490
65	400,00	0,05	3,5	169	3490
61	500,00	0,04	2,8	180	3490
73	600,00	0,04	2,3	180	3490
73	750,00	0,04	1,9	210	3490
73	900,00	0,03	1,6	210	3490
73	1200,00	0,03	1,2	210	3490
73	1500,00	0,02	0,9	210	3490
73	1800,00	0,02	0,8	210	3490
65	2400,00	0,01	0,6	210	3490
60	3000,00	0,01	0,5	210	3490
48	4000,00	0,01	0,4	210	3490
43	5000,00	0,01	0,3	210	3490

## ISW030/050

Mn <sub>2</sub> [Nm]	i	Pn <sub>1</sub> [kW]	n <sub>2</sub> [rpm]	Fr1 [N]	Fr2 [N]
137	100,00	0,31	14,0	169	3800
135	150,00	0,22	9,3	169	4350
120	200,00	0,15	7,0	169	4788
110	250,00	0,12	5,6	169	4840
145	300,00	0,14	4,7	169	4840
124	400,00	0,10	3,5	169	4840
120	500,00	0,08	2,8	169	4840
145	600,00	0,08	2,3	180	4840
145	750,00	0,07	1,9	210	4840
145	900,00	0,06	1,6	210	4840
145	1200,00	0,05	1,2	210	4840
145	1500,00	0,04	0,9	210	4840
145	1800,00	0,04	0,8	210	4840
124	2400,00	0,03	0,6	210	4840
120	3000,00	0,02	0,5	210	4840
82	4000,00	0,01	0,4	210	4840
79	5000,00	0,01	0,3	210	4840

## ISW030/063

$Mn_2$ [Nm]	i	$Pn_1$ [kW]	n2 [rpm]	Fr1 [N]	Fr2 [N]
150	100,00	0,34	14,0	169	4967
150	150,00	0,24	9,3	169	4967
142	200,00	0,18	7,0	180	4967
174	250,00	0,19	5,6	210	4967
255	300,00	0,26	4,7	150	6270
255	400,00	0,20	3,5	169	6270
236	500,00	0,16	2,8	169	6270
271	600,00	0,15	2,3	180	6270
271	750,00	0,13	1,9	210	6270
271	900,00	0,11	1,6	210	6270
271	1200,00	0,09	1,2	210	6270
271	1500,00	0,08	0,9	210	6270
271	1800,00	0,07	0,8	210	6270
255	2400,00	0,05	0,6	210	6270
236	3000,00	0,04	0,5	210	6270
236	4000,00	0,04	0,4	210	6270
150	5000,00	0,02	0,3	210	6270

## ISW040/075

$Mn_2$ [Nm]	i	$Pn_1$ [kW]	n2 [rpm]	Fr1 [N]	Fr2 [N]
352	100,00	0,76	14,0	344	5863
425	150,00	0,64	9,3	344	6712
420	200,00	0,50	7,0	344	7380
380	250,00	0,38	5,6	344	7380
444	300,00	0,40	4,7	344	7380
414	400,00	0,30	3,5	344	7380
368	500,00	0,24	2,8	344	7380
444	600,00	0,21	2,3	350	7380
444	750,00	0,18	1,9	350	7380
444	900,00	0,16	1,6	350	7380
444	1200,00	0,13	1,2	350	7380
444	1500,00	0,11	0,9	350	7380
444	1800,00	0,10	0,8	350	7380
414	2400,00	0,07	0,6	350	7380
368	3000,00	0,06	0,5	350	7380
368	4000,00	0,05	0,4	350	7380
368	5000,00	0,04	0,3	350	7380

## ISW040/090

$Mn_2$ [Nm]	$i$	$Pn_1$ [kW]	$n_2$ [rpm]	$Fr_1$ [N]	$Fr_2$ [N]
361	100,00	0,76	14,0	344	6487
361	150,00	0,52	9,3	344	6487
353	200,00	0,40	7,0	350	6487
570	250,00	0,55	5,6	344	8180
700	300,00	0,60	4,7	344	8180
610	400,00	0,42	3,5	344	8180
560	500,00	0,33	2,8	344	8180
700	600,00	0,32	2,3	350	8180
700	750,00	0,27	1,9	350	8180
700	900,00	0,24	1,6	350	8180
700	1200,00	0,19	1,2	350	8180
700	1500,00	0,16	0,9	350	8180
700	1800,00	0,14	0,8	350	8180
610	2400,00	0,10	0,6	350	8180
560	3000,00	0,08	0,5	350	8180
560	4000,00	0,07	0,4	350	8180
560	5000,00	0,06	0,3	350	8180

## ISW050/090

$Mn_2$ [Nm]	$i$	$Pn_1$ [kW]	$n_2$ [rpm]	$Fr_1$ [N]	$Fr_2$ [N]
590	100,00	1,21	14,0	490	6487
660	150,00	0,95	9,3	490	7426
610	200,00	0,69	7,0	490	8174
570	250,00	0,53	5,6	490	8180
700	300,00	0,59	4,7	490	8180
610	400,00	0,41	3,5	490	8180
570	500,00	0,29	2,8	490	8180
700	600,00	0,32	2,3	490	8180
700	750,00	0,27	1,9	490	8180
700	900,00	0,23	1,6	490	8180
700	1200,00	0,19	1,2	490	8180
700	1500,00	0,16	0,9	490	8180
700	1800,00	0,14	0,8	490	8180
610	2400,00	0,10	0,6	490	8180
560	3000,00	0,08	0,5	490	8180
560	4000,00	0,07	0,4	490	8180
560	5000,00	0,06	0,3	490	8180

## ISW050/105

$Mn_2$ [Nm]	$i$	$Pn_1$ [kW]	$n_2$ [rpm]	$Fr_1$ [N]	$Fr_2$ [N]
648	100,00	1,33	14,0	490	8198
936	150,00	1,33	9,3	490	9384
990	200,00	1,08	7,0	490	10320
1020	250,00	0,92	5,6	490	10320
1100	300,00	0,92	4,7	490	10320
1030	400,00	0,67	3,5	490	10320
1020	500,00	0,50	2,8	490	10320
1100	600,00	0,50	2,3	490	10320
1100	750,00	0,42	1,9	490	10320
1100	900,00	0,37	1,6	490	10320
1100	1200,00	0,29	1,2	490	10320
1100	1500,00	0,25	0,9	490	10320
1100	1800,00	0,22	0,8	490	10320
1030	2400,00	0,16	0,6	490	10320
1000	3000,00	0,13	0,5	490	10320
1000	4000,00	0,11	0,4	490	10320
1000	5000,00	0,09	0,3	490	10320



## ISW030

$Mn_2$ [Nm]	$i$	$Pn_1$ [kW]	$n_2$ [rpm]	$Fr_1$ [N]	$Fr_2$ [N]
20	5,00	0,56	228,0	175	639
20	7,50	0,38	152,0	175	732
20	10,00	0,29	114,0	197	805
20	15,00	0,21	76,0	197	922
19	20,00	0,16	57,0	210	1015
23	25,00	0,16	46,0	210	1093
21	30,00	0,13	38,0	210	1162
20	40,00	0,10	29,0	210	1278
19	50,00	0,08	23,0	210	1377
17	60,00	0,07	19,0	210	1463
14	80,00	0,05	14,0	210	1611

## ISW040

$Mn_2$ [Nm]	$i$	$Pn_1$ [kW]	$n_2$ [rpm]	$Fr_1$ [N]	$Fr_2$ [N]
39	5,00	1,06	228,0	290	1230
44	7,50	0,81	152,0	327	1408
46	10,00	0,65	114,0	350	1550
47	15,00	0,46	76,0	350	1774
46	20,00	0,35	57,0	350	1953
42	25,00	0,27	46,0	350	2104
51	30,00	0,29	38,0	350	2235
48	40,00	0,22	29,0	350	2460
44	50,00	0,17	23,0	350	2650
40	60,00	0,14	19,0	350	2816
34	80,00	0,10	14,0	350	3100
31	100,00	0,08	11,0	350	3339

## ISW050

$Mn_2$ [Nm]	$i$	$Pn_1$ [kW]	$n_2$ [rpm]	$Fr_1$ [N]	$Fr_2$ [N]
75	5,00	2,01	228,0	400	1689
84	7,50	1,54	152,0	448	1933
86	10,00	1,19	114,0	490	2127
86	15,00	0,84	76,0	490	2435
80	20,00	0,61	57,0	490	2680
73	25,00	0,46	46,0	490	2887
91	30,00	0,51	38,0	490	3068
85	40,00	0,38	29,0	490	3377
79	50,00	0,30	23,0	490	3638
74	60,00	0,25	19,0	490	3866

## ISW050

$Mn_2$ [Nm]	i	$Pn_1$ [kW]	n2 [rpm]	Fr1 [N]	Fr2 [N]
66	80,00	0,19	14,0	490	4255
55	100,00	0,14	11,0	490	4583

## ISW063

$Mn_2$ [Nm]	i	$Pn_1$ [kW]	n2 [rpm]	Fr1 [N]	Fr2 [N]
139	7,50	2,51	152,0	580	2527
143	10,00	1,97	114,0	667	2781
159	15,00	1,52	76,0	700	3183
154	20,00	1,14	57,0	700	3504
141	25,00	0,87	46,0	700	3774
168	30,00	0,91	38,0	700	4011
160	40,00	0,69	29,0	700	4414
152	50,00	0,56	23,0	700	4755
144	60,00	0,47	19,0	700	5053
129	80,00	0,34	14,0	700	5562
121	100,00	0,29	11,0	700	5991

## ISW075

$Mn_2$ [Nm]	i	$Pn_1$ [kW]	n2 [rpm]	Fr1 [N]	Fr2 [N]
200	7,50	3,59	152,0	810	2982
212	10,00	2,92	114,0	968	3282
250	15,00	2,36	76,0	980	3757
250	20,00	1,84	57,0	980	4135
228	25,00	1,38	46,0	980	4455
264	30,00	1,41	38,0	980	4734
262	40,00	1,11	29,0	980	5210
240	50,00	0,86	23,0	980	5613
231	60,00	0,73	19,0	980	5964
207	80,00	0,54	14,0	980	6565
188	100,00	0,43	11,0	980	7071

## ISW090

$Mn_2$ [Nm]	i	$Pn_1$ [kW]	n2 [rpm]	Fr1 [N]	Fr2 [N]
347	7,50	6,16	152,0	1040	3300
374	10,00	5,06	114,0	1270	3632
429	15,00	3,96	76,0	1270	4157
410	20,00	2,92	57,0	1270	4576

## ISW090

$Mn_2$ [Nm]	$i$	$Pn_1$ [kW]	$n_2$ [rpm]	$Fr_1$ [N]	$Fr_2$ [N]
390	25,00	2,28	46,0	1270	4929
459	30,00	2,35	38,0	1270	5238
423	40,00	1,70	29,0	1270	5765
402	50,00	1,34	23,0	1270	6210
369	60,00	1,08	19,0	1270	6599
300	80,00	0,72	14,0	1270	7264
275	100,00	0,57	11,0	1270	7824

## ISW105

$Mn_2$ [Nm]	$i$	$Pn_1$ [kW]	$n_2$ [rpm]	$Fr_1$ [N]	$Fr_2$ [N]
576	7,50	10,23	152,0	1270	4169
598	10,00	8,06	114,0	1270	4589
627	15,00	5,76	76,0	1270	5253
632	20,00	4,43	57,0	1270	5782
625	25,00	3,56	46,0	1270	6228
654	30,00	3,30	38,0	1270	6619
660	40,00	2,54	29,0	1270	7285
625	50,00	2,01	23,0	1270	7847
606	60,00	1,67	19,0	1270	8339
515	80,00	1,16	14,0	1270	9178
474	100,00	0,91	11,0	1270	9887

## ISW030/040

Mn <sub>2</sub> [Nm]	i	Pn <sub>1</sub> [kW]	n <sub>2</sub> [rpm]	Fr1 [N]	Fr2 [N]
71	100,00	0,13	11,4	197	2769
72	150,00	0,10	7,6	197	3169
65	200,00	0,07	5,7	197	3488
61	250,00	0,05	4,6	197	3490
73	300,00	0,06	3,8	197	3490
65	400,00	0,04	2,9	197	3490
61	500,00	0,03	2,3	210	3490
73	600,00	0,03	1,9	210	3490
73	750,00	0,03	1,5	210	3490
73	900,00	0,03	1,3	210	3490
73	1200,00	0,02	1,0	210	3490
73	1500,00	0,02	0,8	210	3490
73	1800,00	0,02	0,6	210	3490
65	2400,00	0,01	0,5	210	3490
60	3000,00	0,01	0,4	210	3490
48	4000,00	0,01	0,3	210	3490
43	5000,00	0,01	0,2	210	3490

## ISW030/050

Mn <sub>2</sub> [Nm]	i	Pn <sub>1</sub> [kW]	n <sub>2</sub> [rpm]	Fr1 [N]	Fr2 [N]
137	100,00	0,25	11,4	197	3800
135	150,00	0,18	7,6	197	4350
120	200,00	0,13	5,7	197	4788
110	250,00	0,10	4,6	197	4840
145	300,00	0,12	3,8	197	4840
124	400,00	0,08	2,9	197	4840
120	500,00	0,07	2,3	197	4840
145	600,00	0,07	1,9	210	4840
145	750,00	0,06	1,5	210	4840
145	900,00	0,05	1,3	210	4840
145	1200,00	0,04	1,0	210	4840
145	1500,00	0,04	0,8	210	4840
145	1800,00	0,03	0,6	210	4840
124	2400,00	0,02	0,5	210	4840
120	3000,00	0,02	0,4	210	4840
82	4000,00	0,01	0,3	210	4840
79	5000,00	0,01	0,2	210	4840

## ISW030/063

$Mn_2$ [Nm]	i	$Pn_1$ [kW]	n2 [rpm]	Fr1 [N]	Fr2 [N]
158	100,00	0,29	11,4	197	4967
158	150,00	0,21	7,6	197	4967
150	200,00	0,16	5,7	210	4967
182	250,00	0,16	4,6	210	4967
255	300,00	0,22	3,8	175	6270
255	400,00	0,17	2,9	197	6270
236	500,00	0,13	2,3	197	6270
271	600,00	0,12	1,9	210	6270
271	750,00	0,11	1,5	210	6270
271	900,00	0,09	1,3	210	6270
271	1200,00	0,08	1,0	210	6270
271	1500,00	0,07	0,8	210	6270
271	1800,00	0,06	0,6	210	6270
255	2400,00	0,04	0,5	210	6270
236	3000,00	0,04	0,4	210	6270
236	4000,00	0,03	0,3	210	6270
150	5000,00	0,02	0,2	210	6270

## ISW040/075

$Mn_2$ [Nm]	i	$Pn_1$ [kW]	n2 [rpm]	Fr1 [N]	Fr2 [N]
368	100,00	0,65	11,4	350	5863
425	150,00	0,53	7,6	350	6712
420	200,00	0,41	5,7	350	7380
380	250,00	0,31	4,6	350	7380
444	300,00	0,33	3,8	350	7380
414	400,00	0,25	2,9	350	7380
368	500,00	0,19	2,3	350	7380
444	600,00	0,18	1,9	350	7380
444	750,00	0,15	1,5	350	7380
444	900,00	0,13	1,3	350	7380
444	1200,00	0,11	1,0	350	7380
444	1500,00	0,09	0,8	350	7380
444	1800,00	0,08	0,6	350	7380
414	2400,00	0,06	0,5	350	7380
368	3000,00	0,05	0,4	350	7380
368	4000,00	0,04	0,3	350	7380
368	5000,00	0,04	0,2	350	7380

## ISW040/090

$Mn_2$ [Nm]	$i$	$Pn_1$ [kW]	$n_2$ [rpm]	$Fr_1$ [N]	$Fr_2$ [N]
377	100,00	0,65	11,4	350	6487
385	150,00	0,46	7,6	350	6487
373	200,00	0,35	5,7	350	6487
570	250,00	0,45	4,6	350	8180
700	300,00	0,49	3,8	350	8180
610	400,00	0,35	2,9	350	8180
560	500,00	0,27	2,3	350	8180
700	600,00	0,27	1,9	350	8180
700	750,00	0,22	1,5	350	8180
700	900,00	0,20	1,3	350	8180
700	1200,00	0,16	1,0	350	8180
700	1500,00	0,14	0,8	350	8180
700	1800,00	0,12	0,6	350	8180
610	2400,00	0,09	0,5	350	8180
560	3000,00	0,07	0,4	350	8180
560	4000,00	0,06	0,3	350	8180
560	5000,00	0,05	0,2	350	8180

## ISW050/090

$Mn_2$ [Nm]	$i$	$Pn_1$ [kW]	$n_2$ [rpm]	$Fr_1$ [N]	$Fr_2$ [N]
590	100,00	1,00	11,4	490	6487
660	150,00	0,78	7,6	490	7426
610	200,00	0,56	5,7	490	8174
570	250,00	0,44	4,6	490	8180
700	300,00	0,48	3,8	490	8180
610	400,00	0,34	2,9	490	8180
570	500,00	0,24	2,3	490	8180
700	600,00	0,26	1,9	490	8180
700	750,00	0,22	1,5	490	8180
700	900,00	0,20	1,3	490	8180
700	1200,00	0,16	1,0	490	8180
700	1500,00	0,13	0,8	490	8180
700	1800,00	0,12	0,6	490	8180
610	2400,00	0,08	0,5	490	8180
560	3000,00	0,07	0,4	490	8180
560	4000,00	0,06	0,3	490	8180
560	5000,00	0,05	0,2	490	8180

## ISW050/105

$Mn_2$ [Nm]	$i$	$Pn_1$ [kW]	$n_2$ [rpm]	$Fr_1$ [N]	$Fr_2$ [N]
702	100,00	1,19	11,4	490	8198
1014	150,00	1,19	7,6	490	9384
990	200,00	0,89	5,7	490	10320
1020	250,00	0,76	4,6	490	10320
1100	300,00	0,76	3,8	490	10320
1030	400,00	0,55	2,9	490	10320
1020	500,00	0,41	2,3	490	10320
1100	600,00	0,41	1,9	490	10320
1100	750,00	0,34	1,5	490	10320
1100	900,00	0,31	1,3	490	10320
1100	1200,00	0,25	1,0	490	10320
1100	1500,00	0,21	0,8	490	10320
1100	1800,00	0,19	0,6	490	10320
1030	2400,00	0,14	0,5	490	10320
1000	3000,00	0,11	0,4	490	10320
1000	4000,00	0,09	0,3	490	10320
1000	5000,00	0,08	0,2	490	10320

## ISW030

$Mn_2$ [Nm]	$i$	$Pn_1$ [kW]	$n_2$ [rpm]	$Fr_1$ [N]	$Fr_2$ [N]
21	5,00	0,47	180,0	175	692
21	7,50	0,32	120,0	175	792
21	10,00	0,24	90,0	197	871
21	15,00	0,18	60,0	197	997
20	20,00	0,13	45,0	210	1098
24	25,00	0,14	36,0	210	1183
22	30,00	0,11	30,0	210	1257
21	40,00	0,09	23,0	210	1383
19	50,00	0,07	18,0	210	1490
17	60,00	0,06	15,0	210	1583
15	80,00	0,04	11,0	210	1743

## ISW040

$Mn_2$ [Nm]	$i$	$Pn_1$ [kW]	$n_2$ [rpm]	$Fr_1$ [N]	$Fr_2$ [N]
42	5,00	0,91	180,0	290	1331
46	7,50	0,68	120,0	318	1524
48	10,00	0,55	90,0	350	1677
50	15,00	0,40	60,0	350	1920
48	20,00	0,30	45,0	350	2113
45	25,00	0,23	36,0	350	2276
53	30,00	0,25	30,0	350	2419
50	40,00	0,19	23,0	350	2662
46	50,00	0,15	18,0	350	2868
41	60,00	0,12	15,0	350	3047
35	80,00	0,08	11,0	350	3354
32	100,00	0,07	9,0	350	3490

## ISW050

$Mn_2$ [Nm]	$i$	$Pn_1$ [kW]	$n_2$ [rpm]	$Fr_1$ [N]	$Fr_2$ [N]
82	5,00	1,76	180,0	400	1827
91	7,50	1,33	120,0	444	2091
92	10,00	1,02	90,0	490	2302
92	15,00	0,72	60,0	490	2635
83	20,00	0,51	45,0	490	2900
76	25,00	0,39	36,0	490	3124
94	30,00	0,43	30,0	490	3320
88	40,00	0,32	23,0	490	3654
81	50,00	0,25	18,0	490	3936
76	60,00	0,21	15,0	490	4183



## ISW050

$Mn_2$ [Nm]	i	$Pn_1$ [kW]	n2 [rpm]	Fr1 [N]	Fr2 [N]
68	80,00	0,16	11,0	490	4604
56	100,00	0,12	9,0	490	4840

## ISW063

$Mn_2$ [Nm]	i	$Pn_1$ [kW]	n2 [rpm]	Fr1 [N]	Fr2 [N]
151	7,50	2,16	120,0	580	2734
153	10,00	1,70	90,0	661	3009
171	15,00	1,31	60,0	700	3444
163	20,00	0,99	45,0	700	3791
149	25,00	0,74	36,0	700	4084
177	30,00	0,78	30,0	700	4339
171	40,00	0,61	23,0	700	4776
161	50,00	0,49	18,0	700	5145
153	60,00	0,41	15,0	700	5467
137	80,00	0,30	11,0	700	6018
124	100,00	0,24	9,0	700	6270

## ISW075

$Mn_2$ [Nm]	i	$Pn_1$ [kW]	n2 [rpm]	Fr1 [N]	Fr2 [N]
215	7,50	3,07	120,0	810	3227
230	10,00	2,52	90,0	975	3551
264	15,00	2,00	60,0	980	4065
268	20,00	1,58	45,0	980	4474
241	25,00	1,16	36,0	980	4820
285	30,00	1,21	30,0	980	5122
277	40,00	0,95	23,0	980	5637
255	50,00	0,75	18,0	980	6073
247	60,00	0,63	15,0	980	6453
220	80,00	0,46	11,0	980	7103
196	100,00	0,36	9,0	980	7380

## ISW090

$Mn_2$ [Nm]	i	$Pn_1$ [kW]	n2 [rpm]	Fr1 [N]	Fr2 [N]
374	7,50	5,28	120,0	1040	3570
407	10,00	4,41	90,0	1270	3929
462	15,00	3,41	60,0	1270	4498
429	20,00	2,47	45,0	1270	4951

## ISW090

$Mn_2$ [Nm]	$i$	$Pn_1$ [kW]	$n_2$ [rpm]	$Fr_1$ [N]	$Fr_2$ [N]
407	25,00	1,92	36,0	1270	5333
485	30,00	2,00	30,0	1270	5667
451	40,00	1,48	23,0	1270	6238
429	50,00	1,17	18,0	1270	6719
385	60,00	0,93	15,0	1270	7140
315	80,00	0,62	11,0	1270	7859
280	100,00	0,48	9,0	1270	8180

## ISW105

$Mn_2$ [Nm]	$i$	$Pn_1$ [kW]	$n_2$ [rpm]	$Fr_1$ [N]	$Fr_2$ [N]
624	7,50	8,81	120,0	1270	4511
651	10,00	6,97	90,0	1270	4965
673	15,00	4,92	60,0	1270	5684
670	20,00	3,76	45,0	1270	6256
660	25,00	3,03	36,0	1270	6739
702	30,00	2,86	30,0	1270	7161
700	40,00	2,20	23,0	1270	7882
665	50,00	1,74	18,0	1270	8491
637	60,00	1,45	15,0	1270	9023
540	80,00	0,99	11,0	1270	9931
490	100,00	0,78	9,0	1270	10320

## ISW030/040

Mn <sub>2</sub> [Nm]	i	Pn <sub>1</sub> [kW]	n <sub>2</sub> [rpm]	Fr1 [N]	Fr2 [N]
71	100,00	0,11	9,0	197	2769
72	150,00	0,08	6,0	197	3169
65	200,00	0,05	4,5	197	3488
61	250,00	0,04	3,6	197	3490
73	300,00	0,05	3,0	197	3490
65	400,00	0,04	2,3	197	3490
61	500,00	0,03	1,8	210	3490
73	600,00	0,03	1,5	210	3490
73	750,00	0,02	1,2	210	3490
73	900,00	0,02	1,0	210	3490
73	1200,00	0,02	0,8	210	3490
73	1500,00	0,01	0,6	210	3490
73	1800,00	0,01	0,5	210	3490
65	2400,00	0,01	0,4	210	3490
60	3000,00	0,01	0,3	210	3490
48	4000,00	0,01	0,2	210	3490
43	5000,00	0,00	0,2	210	3490

## ISW030/050

Mn <sub>2</sub> [Nm]	i	Pn <sub>1</sub> [kW]	n <sub>2</sub> [rpm]	Fr1 [N]	Fr2 [N]
137	100,00	0,20	9,0	197	3800
135	150,00	0,14	6,0	197	4350
120	200,00	0,10	4,5	197	4788
110	250,00	0,08	3,6	197	4840
145	300,00	0,09	3,0	197	4840
124	400,00	0,07	2,3	197	4840
120	500,00	0,06	1,8	197	4840
145	600,00	0,05	1,5	210	4840
145	750,00	0,05	1,2	210	4840
145	900,00	0,04	1,0	210	4840
145	1200,00	0,03	0,8	210	4840
145	1500,00	0,03	0,6	210	4840
145	1800,00	0,03	0,5	210	4840
124	2400,00	0,02	0,4	210	4840
120	3000,00	0,02	0,3	210	4840
82	4000,00	0,01	0,2	210	4840
79	5000,00	0,01	0,2	210	4840

## ISW030/063

$Mn_2$ [Nm]	$i$	$Pn_1$ [kW]	$n_2$ [rpm]	$Fr_1$ [N]	$Fr_2$ [N]
166	100,00	0,24	9,0	197	4967
166	150,00	0,18	6,0	197	4967
158	200,00	0,13	4,5	210	4967
190	250,00	0,14	3,6	210	4967
255	300,00	0,17	3,0	175	6270
255	400,00	0,13	2,3	197	6270
236	500,00	0,11	1,8	197	6270
271	600,00	0,10	1,5	210	6270
271	750,00	0,09	1,2	210	6270
271	900,00	0,08	1,0	210	6270
271	1200,00	0,06	0,8	210	6270
271	1500,00	0,05	0,6	210	6270
271	1800,00	0,05	0,5	210	6270
255	2400,00	0,04	0,4	210	6270
236	3000,00	0,03	0,3	210	6270
236	4000,00	0,03	0,2	210	6270
150	5000,00	0,01	0,2	210	6270

## ISW040/075

$Mn_2$ [Nm]	$i$	$Pn_1$ [kW]	$n_2$ [rpm]	$Fr_1$ [N]	$Fr_2$ [N]
384	100,00	0,55	9,0	350	5863
425	150,00	0,42	6,0	350	6712
420	200,00	0,33	4,5	350	7380
380	250,00	0,25	3,6	350	7380
444	300,00	0,26	3,0	350	7380
414	400,00	0,20	2,3	350	7380
368	500,00	0,15	1,8	350	7380
444	600,00	0,14	1,5	350	7380
444	750,00	0,12	1,2	350	7380
444	900,00	0,11	1,0	350	7380
444	1200,00	0,09	0,8	350	7380
444	1500,00	0,08	0,6	350	7380
444	1800,00	0,07	0,5	350	7380
414	2400,00	0,05	0,4	350	7380
368	3000,00	0,04	0,3	350	7380
368	4000,00	0,03	0,2	350	7380
368	5000,00	0,03	0,2	350	7380

## ISW040/090

$Mn_2$ [Nm]	$i$	$Pn_1$ [kW]	$n_2$ [rpm]	$Fr_1$ [N]	$Fr_2$ [N]
394	100,00	0,55	9,0	350	6487
410	150,00	0,40	6,0	350	6487
394	200,00	0,30	4,5	350	6487
570	250,00	0,36	3,6	350	8180
700	300,00	0,40	3,0	350	8180
610	400,00	0,28	2,3	350	8180
560	500,00	0,22	1,8	350	8180
700	600,00	0,22	1,5	350	8180
700	750,00	0,18	1,2	350	8180
700	900,00	0,16	1,0	350	8180
700	1200,00	0,13	0,8	350	8180
700	1500,00	0,11	0,6	350	8180
700	1800,00	0,10	0,5	350	8180
610	2400,00	0,07	0,4	350	8180
560	3000,00	0,06	0,3	350	8180
560	4000,00	0,05	0,2	350	8180
560	5000,00	0,04	0,2	350	8180

## ISW050/090

$Mn_2$ [Nm]	$i$	$Pn_1$ [kW]	$n_2$ [rpm]	$Fr_1$ [N]	$Fr_2$ [N]
590	100,00	0,80	9,0	490	6487
660	150,00	0,63	6,0	490	7426
610	200,00	0,45	4,5	490	8174
570	250,00	0,35	3,6	490	8180
700	300,00	0,39	3,0	490	8180
610	400,00	0,27	2,3	490	8180
570	500,00	0,19	1,8	490	8180
700	600,00	0,21	1,5	490	8180
700	750,00	0,18	1,2	490	8180
700	900,00	0,16	1,0	490	8180
700	1200,00	0,13	0,8	490	8180
700	1500,00	0,11	0,6	490	8180
700	1800,00	0,10	0,5	490	8180
610	2400,00	0,07	0,4	490	8180
560	3000,00	0,05	0,3	490	8180
560	4000,00	0,04	0,2	490	8180
560	5000,00	0,04	0,2	490	8180

## ISW050/105

$Mn_2$ [Nm]	$i$	$Pn_1$ [kW]	$n_2$ [rpm]	$Fr_1$ [N]	$Fr_2$ [N]
754	100,00	1,02	9,0	490	8198
1040	150,00	0,97	6,0	490	9384
990	200,00	0,71	4,5	490	10320
1020	250,00	0,60	3,6	490	10320
1100	300,00	0,61	3,0	490	10320
1030	400,00	0,44	2,3	490	10320
1020	500,00	0,33	1,8	490	10320
1100	600,00	0,33	1,5	490	10320
1100	750,00	0,28	1,2	490	10320
1100	900,00	0,25	1,0	490	10320
1100	1200,00	0,20	0,8	490	10320
1100	1500,00	0,17	0,6	490	10320
1100	1800,00	0,15	0,5	490	10320
1030	2400,00	0,11	0,4	490	10320
1000	3000,00	0,09	0,3	490	10320
1000	4000,00	0,08	0,2	490	10320
1000	5000,00	0,07	0,2	490	10320

## ISW030

$Mn_2$ [Nm]	$i$	$Pn_1$ [kW]	$n_2$ [rpm]	$Fr_1$ [N]	$Fr_2$ [N]
25	5,00	0,31	100,0	210	841
25	7,50	0,22	67,0	210	963
25	10,00	0,17	50,0	210	1060
25	15,00	0,12	33,0	210	1213
23	20,00	0,09	25,0	210	1336
30	25,00	0,10	20,0	210	1439
27	30,00	0,08	17,0	210	1529
24	40,00	0,06	13,0	210	1683
22	50,00	0,05	10,0	210	1813
19	60,00	0,04	8,0	210	1830
17	80,00	0,03	6,0	210	1830

## ISW040

$Mn_2$ [Nm]	$i$	$Pn_1$ [kW]	$n_2$ [rpm]	$Fr_1$ [N]	$Fr_2$ [N]
52	5,00	0,63	100,0	350	1619
56	7,50	0,47	67,0	350	1853
59	10,00	0,38	50,0	350	2040
61	15,00	0,28	33,0	350	2335
57	20,00	0,20	25,0	350	2570
51	25,00	0,15	20,0	350	2769
62	30,00	0,17	17,0	350	2942
58	40,00	0,13	13,0	350	3238
53	50,00	0,10	10,0	350	3488
48	60,00	0,08	8,0	350	3490
40	80,00	0,06	6,0	350	3490
36	100,00	0,05	5,0	350	3490

## ISW050

$Mn_2$ [Nm]	$i$	$Pn_1$ [kW]	$n_2$ [rpm]	$Fr_1$ [N]	$Fr_2$ [N]
101	5,00	1,23	100,0	490	2222
112	7,50	0,93	67,0	490	2544
113	10,00	0,72	50,0	490	2800
113	15,00	0,51	33,0	490	3205
100	20,00	0,35	25,0	490	3528
92	25,00	0,28	20,0	490	3800
113	30,00	0,30	17,0	490	4038
105	40,00	0,23	13,0	490	4445
96	50,00	0,18	10,0	490	4788
87	60,00	0,15	8,0	490	4840

## ISW050

$Mn_2$ [Nm]	i	$Pn_1$ [kW]	$n_2$ [rpm]	$Fr_1$ [N]	$Fr_2$ [N]
75	80,00	0,11	6,0	490	4840
65	100,00	0,08	5,0	490	4840

## ISW063

$Mn_2$ [Nm]	i	$Pn_1$ [kW]	$n_2$ [rpm]	$Fr_1$ [N]	$Fr_2$ [N]
184	7,50	1,49	67,0	700	3325
185	10,00	1,18	50,0	700	3660
200	15,00	0,90	33,0	700	4190
194	20,00	0,68	25,0	700	4611
178	25,00	0,52	20,0	700	4967
213	30,00	0,56	17,0	700	5279
206	40,00	0,44	13,0	700	5810
195	50,00	0,36	10,0	700	6259
180	60,00	0,29	8,0	700	6270
151	80,00	0,21	6,0	700	6270
128	100,00	0,16	5,0	700	6270

## ISW075

$Mn_2$ [Nm]	i	$Pn_1$ [kW]	$n_2$ [rpm]	$Fr_1$ [N]	$Fr_2$ [N]
260	7,50	2,14	67,0	980	3925
270	10,00	1,70	50,0	980	4320
318	15,00	1,39	33,0	980	4945
326	20,00	1,11	25,0	980	5443
293	25,00	0,83	20,0	980	5863
344	30,00	0,87	17,0	980	6231
337	40,00	0,69	13,0	980	6858
314	50,00	0,55	10,0	980	7380
301	60,00	0,46	8,0	980	7380
247	80,00	0,32	6,0	980	7380
210	100,00	0,24	5,0	980	7380

## ISW090

$Mn_2$ [Nm]	i	$Pn_1$ [kW]	$n_2$ [rpm]	$Fr_1$ [N]	$Fr_2$ [N]
451	7,50	3,66	67,0	1270	4343
479	10,00	2,95	50,0	1270	4780
539	15,00	2,29	33,0	1270	5472
517	20,00	1,71	25,0	1270	6022



## ISW090

$Mn_2$ [Nm]	$i$	$Pn_1$ [kW]	$n_2$ [rpm]	$Fr_1$ [N]	$Fr_2$ [N]
484	25,00	1,33	20,0	1270	6487
579	30,00	1,40	17,0	1270	6894
528	40,00	1,03	13,0	1270	7588
495	50,00	0,81	10,0	1270	8174
440	60,00	0,64	8,0	1270	8180
365	80,00	0,44	6,0	1270	8180
330	100,00	0,35	5,0	1270	8180

## ISW105

$Mn_2$ [Nm]	$i$	$Pn_1$ [kW]	$n_2$ [rpm]	$Fr_1$ [N]	$Fr_2$ [N]
762	7,50	6,11	67,0	1270	5488
814	10,00	5,01	50,0	1270	6040
844	15,00	3,55	33,0	1270	6914
836	20,00	2,70	25,0	1270	7610
790	25,00	2,09	20,0	1270	8198
919	30,00	2,20	17,0	1270	8711
903	40,00	1,66	13,0	1270	9588
860	50,00	1,34	10,0	1270	10320
729	60,00	0,99	8,0	1270	10320
630	80,00	0,71	6,0	1270	10320
570	100,00	0,55	5,0	1270	10320

## ISW030/040

Mn <sub>2</sub> [Nm]	i	Pn <sub>1</sub> [kW]	n <sub>2</sub> [rpm]	Fr1 [N]	Fr2 [N]
71	100,00	0,06	5,0	210	2769
72	150,00	0,04	3,3	210	3169
65	200,00	0,03	2,5	210	3488
61	250,00	0,03	2,0	210	3490
73	300,00	0,03	1,7	210	3490
65	400,00	0,02	1,3	210	3490
61	500,00	0,01	1,0	210	3490
73	600,00	0,02	0,8	210	3490
73	750,00	0,01	0,7	210	3490
73	900,00	0,01	0,6	210	3490
73	1200,00	0,01	0,4	210	3490
73	1500,00	0,01	0,3	210	3490
73	1800,00	0,01	0,3	210	3490
65	2400,00	0,01	0,2	210	3490
60	3000,00	0,01	0,2	210	3490
48	4000,00	0,00	0,1	210	3490
43	5000,00	0,00	0,1	210	3490

## ISW030/050

Mn <sub>2</sub> [Nm]	i	Pn <sub>1</sub> [kW]	n <sub>2</sub> [rpm]	Fr1 [N]	Fr2 [N]
137	100,00	0,12	5,0	210	3800
135	150,00	0,08	3,3	210	4350
120	200,00	0,06	2,5	210	4788
110	250,00	0,04	2,0	210	4840
145	300,00	0,05	1,7	210	4840
124	400,00	0,04	1,3	210	4840
120	500,00	0,03	1,0	210	4840
145	600,00	0,03	0,8	210	4840
145	750,00	0,03	0,7	210	4840
145	900,00	0,02	0,6	210	4840
145	1200,00	0,02	0,4	210	4840
145	1500,00	0,02	0,3	210	4840
145	1800,00	0,02	0,3	210	4840
124	2400,00	0,01	0,2	210	4840
120	3000,00	0,01	0,2	210	4840
82	4000,00	0,01	0,1	210	4840
79	5000,00	0,01	0,1	210	4840

## ISW030/063

$Mn_2$ [Nm]	$i$	$Pn_1$ [kW]	$n_2$ [rpm]	$Fr_1$ [N]	$Fr_2$ [N]
198	100,00	0,17	5,0	210	4967
198	150,00	0,12	3,3	210	4967
182	200,00	0,09	2,5	210	4967
237	250,00	0,10	2,0	210	4967
255	300,00	0,10	1,7	210	6270
255	400,00	0,08	1,3	210	6270
236	500,00	0,06	1,0	210	6270
271	600,00	0,06	0,8	210	6270
271	750,00	0,05	0,7	210	6270
271	900,00	0,04	0,6	210	6270
271	1200,00	0,04	0,4	210	6270
271	1500,00	0,03	0,3	210	6270
271	1800,00	0,03	0,3	210	6270
255	2400,00	0,02	0,2	210	6270
236	3000,00	0,02	0,2	210	6270
236	4000,00	0,02	0,1	210	6270
150	5000,00	0,01	0,1	210	6270

## ISW040/075

$Mn_2$ [Nm]	$i$	$Pn_1$ [kW]	$n_2$ [rpm]	$Fr_1$ [N]	$Fr_2$ [N]
405	100,00	0,33	5,0	350	5863
425	150,00	0,24	3,3	350	6712
420	200,00	0,19	2,5	350	7380
380	250,00	0,14	2,0	350	7380
444	300,00	0,15	1,7	350	7380
414	400,00	0,11	1,3	350	7380
368	500,00	0,09	1,0	350	7380
444	600,00	0,08	0,8	350	7380
444	750,00	0,07	0,7	350	7380
444	900,00	0,06	0,6	350	7380
444	1200,00	0,05	0,4	350	7380
444	1500,00	0,04	0,3	350	7380
444	1800,00	0,04	0,3	350	7380
414	2400,00	0,03	0,2	350	7380
368	3000,00	0,02	0,2	350	7380
368	4000,00	0,02	0,1	350	7380
368	5000,00	0,02	0,1	350	7380

## ISW040/090

$Mn_2$ [Nm]	$i$	$Pn_1$ [kW]	$n_2$ [rpm]	$Fr_1$ [N]	$Fr_2$ [N]
484	100,00	0,38	5,0	350	6487
500	150,00	0,28	3,3	350	6487
467	200,00	0,20	2,5	350	6487
570	250,00	0,20	2,0	350	8180
700	300,00	0,23	1,7	350	8180
610	400,00	0,16	1,3	350	8180
560	500,00	0,12	1,0	350	8180
700	600,00	0,12	0,8	350	8180
700	750,00	0,10	0,7	350	8180
700	900,00	0,09	0,6	350	8180
700	1200,00	0,08	0,4	350	8180
700	1500,00	0,07	0,3	350	8180
700	1800,00	0,06	0,3	350	8180
610	2400,00	0,04	0,2	350	8180
560	3000,00	0,03	0,2	350	8180
560	4000,00	0,03	0,1	350	8180
560	5000,00	0,03	0,1	350	8180

## ISW050/090

$Mn_2$ [Nm]	$i$	$Pn_1$ [kW]	$n_2$ [rpm]	$Fr_1$ [N]	$Fr_2$ [N]
590	100,00	0,46	5,0	490	6487
660	150,00	0,36	3,3	490	7426
610	200,00	0,26	2,5	490	8174
570	250,00	0,20	2,0	490	8180
700	300,00	0,22	1,7	490	8180
610	400,00	0,16	1,3	490	8180
570	500,00	0,11	1,0	490	8180
700	600,00	0,12	0,8	490	8180
700	750,00	0,10	0,7	490	8180
700	900,00	0,09	0,6	490	8180
700	1200,00	0,08	0,4	490	8180
700	1500,00	0,07	0,3	490	8180
700	1800,00	0,06	0,3	490	8180
610	2400,00	0,04	0,2	490	8180
560	3000,00	0,03	0,2	490	8180
560	4000,00	0,03	0,1	490	8180
560	5000,00	0,03	0,1	490	8180

## ISW050/105

$Mn_2$ [Nm]	$i$	$Pn_1$ [kW]	$n_2$ [rpm]	$Fr_1$ [N]	$Fr_2$ [N]
927	100,00	0,72	5,0	490	8198
1040	150,00	0,56	3,3	490	9384
990	200,00	0,41	2,5	490	10320
1020	250,00	0,35	2,0	490	10320
1100	300,00	0,35	1,7	490	10320
1030	400,00	0,25	1,3	490	10320
1020	500,00	0,19	1,0	490	10320
1100	600,00	0,19	0,8	490	10320
1100	750,00	0,16	0,7	490	10320
1100	900,00	0,15	0,6	490	10320
1100	1200,00	0,12	0,4	490	10320
1100	1500,00	0,10	0,3	490	10320
1100	1800,00	0,09	0,3	490	10320
1030	2400,00	0,07	0,2	490	10320
1000	3000,00	0,05	0,2	490	10320
1000	4000,00	0,05	0,1	490	10320
1000	5000,00	0,04	0,1	490	10320

**ATTENTION!**

The revised data and information, shown in this technical catalogue, replaces the data of the previous editions. Old data is now obsolete. All technical data, dimensions, weights in this catalogue are subject to changes without warning. Illustrations are not binding. You can find the above mentioned data and information on our site [www.motovario.com](http://www.motovario.com); please periodically consult the technical documentation on the web site to be always updated about possible modifications of performances and characteristics of the product.

All supplies effected by MOTOVARIO are governed exclusively by the general terms of sale that you can find on our website:

<http://www.motovario.com/eng/corporate/sales-conditions>



